



NORTEL

Nortel Communication Server 1000

Telephones and Consoles Fundamentals

Release: 6.0
Document Revision: 03.01

www.nortel.com

NN43001-567

Nortel Communication Server 1000
Release: 6.0
Publication: NN43001-567
Document release date: 11 May 2009

Copyright © 2003-2009 Nortel Networks
All Rights Reserved.

LEGAL NOTICE

While the information in this document is believed to be accurate and reliable, except as otherwise expressly agreed to in writing NORTEL PROVIDES THIS DOCUMENT AS IS WITHOUT WARRANTY OR CONDITION OF ANY KIND, EITHER EXPRESS OR IMPLIED. The information and/or products described in this document are subject to change without notice.

Sourced in Canada

Nortel, the Nortel Logo, the Globemark, SL-1, Meridian 1, and Succession are trademarks of Nortel Networks.

All other trademarks are the property of their respective owners.

Contents

New in this release	7
Other changes	7
Introduction	9
Subject	9
Applicable systems	9
Intended audience	11
Conventions	11
Related information	11
How to get Help	12
Attendant consoles	15
Contents	15
Introduction	16
Engineering codes	17
Features	18
Physical description	32
Wiring	41
Installation	43
Operation	57
M2016S Secure Set	79
Contents	79
Introduction	79
Physical description	81
Features	82
Specifications	84
Installation	87
M 3900 description	95
Contents	95
Introduction	96
Automatic Call Failover	98
Physical description	98
Features	105
M3900 accessories and add-ons	114

Key descriptions	124
M3900 (single site) Virtual Office	135
Contents	135
Introduction	135
Description	135
Operating parameters	137
Feature implementation	138
M3900 installation and configuration	141
Contents	141
Reliability	142
Environmental and safety considerations	142
Installation	146
Configuration	162
M3900 Flash Download	177
Contents	177
Introduction	177
Summary of steps	178
Determining software, M3900 PSWV, or firmware versions	202
Flash Download advisements	203
PSDL installation	206
Dynamic PSDL installation	206
Detailed Flash Download procedure	208
Configuration parameters in LD 32	212
Print Firmware Versions on M3900 Telephones	216
Query Disk Firmware Versions	218
Commands for system-wide Flash Download of M3900 telephones	220
Digital telephones line engineering	223
Contents	223
Engineering a telephone line	223
Selecting a Loop	232
Calculating DC Loop Resistance	233
Performing Loop Diagnostic Tests	234
Measuring Impulse Noise	236
Measuring Background Noise	237
Calculating Expected Pulse Loss	237
Measuring DC Loop Resistance	241
Analog (500/2500-type) telephones	243
Contents	243
Introduction	243
Installation and removal	243
Operation	253

Meridian Modular Telephones	257
Contents	257
Introduction	258
General description	258
Physical description	263
Features and options	266
Relocation	272
Specifications	273
Handsets	282
<hr/>	
Meridian Modular Telephones installation	285
Contents	285
Packing and unpacking	285
Installation and removal	285
Designate telephones	295
Cross-connect the telephones	296
<hr/>	
Meridian Modular Telephones add-on modules installation	299
Contents	299
Packing and unpacking	300
Meridian Modular Telephones	300
Analog Terminal Adapter	302
Meridian Communications Adapter and Meridian Programmable Data Adapter	308
Power Supply Board (NTZK models)	317
Power Supply Board (NT2K models)	324
Installing displays	327
External Alert Board	337
Key Expansion Modules	340
Asynchronous Data Option	343
M2317 Data Option	346
Meridian Communications Unit	350
Wall mounting	350
Troubleshooting	351
<hr/>	
M2317 telephone	357
Contents	357
Introduction	357
Feature description	358
Physical description	360
Specifications	367
<hr/>	
M3110, M3310, and M3820 telephones	373
Contents	373
Feature description	374

Physical description	379
Terminal options	383
Configuration and installation	385
Specifications	393

New in this release

No new content is added to this document for Communication Server 1000 for release 6.0.

Other changes

Date	Description
May 2009	Standard 03.01. This document is up-issued to support Communication Server 1000 Release 6.0.
December 2007	Standard 02.01. This document is issued to support Communication Server 1000 (CS 1000) Release 5.5.
May 2007	This document is issued to support Communication Server 1000 Release 5.0. This document contains information previously contained in the following legacy document, now retired: <i>Telephones and Consoles: Description, Installation, and Operation</i> (553-3001-367). No new content has been added for Communication Server 1000 Release 5.0. All references to Communication Server 1000 Release 4.5 are applicable to Communication Server 1000 Release 5.0.
August 2005	Standard 3.00. This document is up-issued for Communication Server 1000 Release 4.5.

September 2004

Standard 2.00. This document is up-issued for Communication Server 1000 Release 4.0.

October 2003

Standard 1.00. This document is a new NTP for Succession 3.0. It was created to support a restructuring of the Documentation Library, which resulted in the merging of multiple legacy NTPs. This new document consolidates information previously contained in the following legacy documents, now retired:

- *Attendant Console Description* (553-2201-117)
- *Digital Telephones Line Engineering*(553-2201-180)
- *Meridian 1 Telephones* (553-3001-108)
- *Meridian 1 European Digital Telephones* (553-3001-114)
- *Telephone and Attendant Console Installation* (553-3001-215)
- *M3900 Series Meridian Digital Telephones* (553-3001-216)
- *Option 11C and 11C Mini Technical Reference Guide* (553-3011-100)

Content from *Option 11C and 11C Mini Technical Reference Guide* also appears in *Circuit Card Reference* (NN43001-311).

Introduction

This document is a global document. Contact your system supplier or your Nortel representative to verify that the hardware and software described are supported in your area.

Subject

This document provides technical information about Meridian analog, digital and modular telephones and attendant consoles. This information includes descriptions, features and specifications; installation and configuration procedures; operation; administration; software, wiring and power requirements; environmental and safety considerations; installing and using add-on modules, data options, and software. A section is also provided on engineering and configuring digital telephone lines.

This document does not provide information about IP Phones. For information on IP Phones, refer to *IP Phones Fundamentals* (NN43001-368).

Note on legacy products and releases

This NTP contains information about systems, components, and features that are compatible with Nortel Communication Server 1000 Release 4.5 software. For more information on legacy products and releases, click the **Technical Documentation** link under **Support** on the Nortel home page:

www.nortel.com/support

Applicable systems

This document applies to the following systems:

- Communication Server 1000S (CS 1000S)
- Communication Server 1000M Chassis (CS 1000M Chassis)
- Communication Server 1000M Cabinet (CS 1000M Cabinet)
- Communication Server 1000M Half Group (CS 1000M HG)
- Communication Server 1000M Single Group (CS 1000M SG)

- Communication Server 1000M Multi Group (CS 1000M MG)
- Communication Server 1000E (CS 1000E)
- Meridian 1 PBX 11C Chassis
- Meridian 1 PBX 11C Cabinet
- Meridian 1 PBX 51C
- Meridian 1 PBX 61C
- Meridian 1 PBX 81
- Meridian 1 PBX 81C

Note: When upgrading software, memory upgrades may be required on the Signaling Server, the Call Server, or both.

System migration

When particular Meridian 1 systems are upgraded to run CS 1000 Release 4.5 software and configured to include a Signaling Server, they become CS 1000M systems. [Table 1 "Meridian 1 systems to CS 1000M systems" \(page 10\)](#) lists each Meridian 1 system that supports an upgrade path to a CS 1000M system.

Table 1
Meridian 1 systems to CS 1000M systems

This Meridian 1 system...	Maps to this CS 1000M system
Meridian 1 PBX 11C Chassis	CS 1000M Chassis
Meridian 1 PBX 11C Cabinet	CS 1000M Cabinet
Meridian 1 PBX 51C	CS 1000M Half Group
Meridian 1 PBX 61C	CS 1000M Single Group
Meridian 1 PBX 81	CS 1000M Multi Group
Meridian 1 PBX 81C	CS 1000M Multi Group

For more information, see one or more of the following NTPs:

- *Communication Server 1000M and Meridian 1 Small System Software Upgrade (NN43011-459)* ()
- *Communication Server 1000M and Meridian 1 Large System Upgrades Overview (NN43021-458)* ()
- *Communication Server 1000S: Upgrade Procedures (NN43031-458)* ()
- *Communication Server 1000E: Upgrade Procedures (NN43041-458)* ()

Intended audience

This document is intended for individuals responsible for installing, configuring, operating, administering, and troubleshooting Meridian proprietary telephones, attendant consoles and add-on modules, and engineering and configuring digital telephone lines.

Conventions

Terminology

In this document, the following systems are referred to generically as "system":

- Communication Server 1000S (CS 1000S)
- Communication Server 1000M (CS 1000M)
- Communication Server 1000E (CS 1000E)
- Meridian 1

The following systems are referred to generically as "Small System":

- Communication Server 1000M Chassis (CS 1000M Chassis)
- Communication Server 1000M Cabinet (CS 1000M Cabinet)
- Meridian 1 PBX 11C Chassis
- Meridian 1 PBX 11C Cabinet

The following systems are referred to generically as "Large System":

- Communication Server 1000M Half Group (CS 1000M HG)
- Communication Server 1000M Single Group (CS 1000M SG)
- Communication Server 1000M Multi Group (CS 1000M MG)
- Meridian 1 PBX 51C
- Meridian 1 PBX 61C
- Meridian 1 PBX 81
- Meridian 1 PBX 81C

Related information

This section lists information sources that relate to this document.

NTPs

The following NTPs are referenced in this document:

- *Spares Planning (NN43001-253)* ()
- *Equipment Identification Reference (NN43001-254)* ()

- *Circuit Card Reference (NN43001-311) ()*
- *Features and Services Fundamentals-Six Books (NN43001-106_B1-B6) ()*
- *Software Input Output Administration (NN43001-611) ()*
- *Attendant PC Console Fundamentals (NN43001-520) ()*
- *Software Input Output Reference - System Messages (NN43001-712) ()*
- *Software Input Output Reference - Maintenance (NN43001-711) ()*
- *Communication Server 1000M and Meridian 1 Small System Software Upgrade (NN43011-459) ()*
- *Communication Server 1000M and Meridian 1 Large System Upgrades Overview (NN43021-458) ()*
- *Analog Terminal Adapter Installation and Reference Guide (NN42370-121) ()*
- *Meridian Digital Telephones M3901, M3902, M3903, M3904 User Guide (NN42370-107) ()*
- *Meridian Digital Telephones M3902, M3903, M3904 Quick Reference Guide (NN42370-105) ()*
- *Meridian Digital Telephone M3905 Call Center User Guide (NN42370-108) ()*

For information on IP Phones, refer to *IP Phones Fundamentals (NN43001-368) ()* .

Online

To access Nortel documentation online, click the **Technical Documentation** link under **Support** on the Nortel home page:

www.nortel.com

CD-ROM

To obtain Nortel documentation on CD-ROM, contact your Nortel customer representative.

How to get Help

Getting Help from the Nortel Web site

The best source of support for Nortel products is the Nortel Support Web site:

www.nortel.com/support

This site enables customers to:

- download software and related tools
- download technical documents, release notes, and product bulletins
- sign up for automatic notification of new software and documentation
- search the Support Web site and Nortel Knowledge Base
- open and manage technical support cases

Getting Help over the phone from a Nortel Solutions Center

If you have a Nortel support contract and cannot find the information you require on the Nortel Support Web site, you can get help over the phone from a Nortel Solutions Center.

In North America, call 1-800-4NORTEL (1-800-466-7865).

Outside North America, go to the Web site below and look up the phone number that applies in your region:

www.nortel.com/callus

When you speak to the phone agent, you can reference an Express Routing Code (ERC) to more quickly route your call to the appropriate support specialist. To locate the ERC for your product or service, go to:

www.nortel.com/erc

Getting Help through a Nortel distributor or reseller

If you purchased a service contract for your Nortel product from a distributor or authorized reseller, you can contact the technical support staff for that distributor or reseller.

Attendant consoles

Contents

This section contains information on the following topics:

- “Introduction” (page 16)
- “Engineering codes” (page 17)
- “Features” (page 18)
 - “Busy Lamp Field/Console Graphics Module” (page 19)
 - “Display backlight power supply option” (page 29)
 - “DSS-9000 Direct Station Select/Busy Lamp Field” (page 29)
 - “Attendant Supervisory Module” (page 29)
- “Physical description” (page 32)
 - “Dimensions” (page 32)
 - “Keyboard layout” (page 36)
 - “Display screen messages” (page 39)
 - “Display screen messages” (page 39)
 - “Connections” (page 40)
 - “Local console controls” (page 40)
- “Wiring” (page 41)
 - “Installing wiring” (page 41)
- “Installation” (page 43)
 - “Normal operating ranges” (page 43)
 - “Packing and unpacking” (page 43)
 - “Installation and removal” (page 43)
 - “Installing the M2250 attendant console” (page 44)
 - “Removing the M2250 attendant console” (page 45)
 - “Removing the M2250 attendant console top cover” (page 45)
 - “Installing the M2250 attendant console top cover” (page 46)

- “Performing a loopback test” (page 47)
- “Designating keys on the M2250 attendant console” (page 48)
- “Cross-connecting attendant consoles” (page 51)
- “Operation” (page 57)
- “M2250 configurations” (page 57)
- “Attendant PC requirements” (page 59)
- “M2250 feature key modes” (page 59)
- “M2250 console diagnostics” (page 61)
- “M2250 failure codes” (page 67)
- “M2250 feature operation” (page 69)

Introduction

Attendant consoles are designed to assist in placing and extending calls into and out of a telephone switching system. The console is operated by an attendant who is the human interface between the system and the users.

The M2250 attendant console is a stand-alone, digital attendant console designed for telephone traffic control in the CS 1000 and Meridian 1. A Digital Line Card (DLC) connects the M2250 to the system.

The PC-based Console application software allows all functions supported by the M2250 to be performed on a computer workstation within a Windows 95[®], Windows 98[®], Windows 2000[®], or Windows NT[®] operating system environment. The PC-based Console application operates with the PC Console Interface Unit (PCCIU). The PCCIU is typically installed under the attendant’s PC monitor, and provides connection to the Main Distribution Frame (MDF) and PC communications port. The PCCIU is configured as an M2250 attendant console in LD 12. Refer to *Software Input Output Administration (NN43001-611)* () for configuration information

In the North America, Asia Pacific and CALA market regions, the PCCIU and the Attendant PC software are available as a bundled package. In the EMEA market region, the PCCIU is available on its own or with a separate PC software application called SMILE.

For more information on Attendant PC and the PCCIU, refer to the following documents:

- *Attendant PC Console Fundamentals (NN43001-520)* ()
- *PC Console Interface Unit Installation Guide* ()
- *PC Console Interface Unit Quick Reference Guide* ()

Engineering codes

Refer to [Table 2 "Engineering codes for the M2250 and related equipment" \(page 17\)](#) for engineering codes for available M2250 attendant console models and related equipment. For ordering information, refer to *Equipment Identification Reference (NN43001-254)* (). For EMEA codes, please contact your local Nortel representative.

Table 2
Engineering codes for the M2250 and related equipment

Engineering code	Model	Color	Order code	Availability
NT3G40BB-35	BLF/CGM	Chameleon	A0652760	CALA, Spain, US
NT3G41BB-35	BLF/CGM	Chameleon Grey	A0652758	APAC, Canada
NT3G41BB-98	BLF/CGM	Dark Grey	A0652759	APAC
NT3G42BA-35	BLF/CGM	N/A	A0642991	Africa, Australia, Austria, Belgium, CIS, Denmark, Europe, Finland, France, Germany, Greece, Holland, Ireland, Middle East, Norway, Portugal, Sweden, Switzerland, Turkey, UK
NT3G42BA-93	BLF/CGM	Dolphin	A0656519	Australia, UK
NT3G42BA-98	BLF/CGM	N/A	A0642994	Finland, France, Germany
NT6G00AF-35	M2250	Chameleon Grey	A0393450	Africa, APAC, CALA, CIS, Greece, Ireland, Middle East, NA, Portugal, Turkey
NT6G40BA-35	M2250	Chameleon Grey	A0642786	Switzerland
NT6G41BB-35	M2250	Chameleon Grey	A0642787	APAC, Norway
NT6G42BC-35	M2250	Chameleon Grey	A0642788	Denmark
NT6G43BA-35	M2250	Chameleon Grey	A0642789	Finland, Germany
NT6G43BA-98	M2250	Dark Grey	A0642790	Finland, Germany
NT6G44BA-35	M2250	Chameleon Grey	A0642791	Austria
NT6G45BA-35	M2250	Chameleon Grey	A0642792	Belgium
NT6G47BB-35	M2250	Chameleon Grey	A0642793	France

Table 2
Engineering codes for the M2250 and related equipment (cont'd.)

Engineering code	Model	Color	Order code	Availability
NT6G47BB-98	M2250	Dark Grey	A0642794	France
NT6G48BC-35	M2250	Chameleon	A0642795	UK
NT6G48BC-93	M2250	Dolphin	A0642796	New Zealand, UK
NT6G50BA-35	M2250	Chameleon	A0642797	Australia
NT6G50BA-93	M2250	Dolphin	A0642798	Australia
NT6G53BB-35	M2250	Chameleon	A0655900	Holland
NT6G55BA-35	M2250	Chameleon Grey	A0642799	Spain
NT6G56BB-35	M2250	Chameleon Grey	A0642802	Sweden
NT6G57BA-35	M2250	Chameleon Grey	A0642803	Italy
NT6G57BA-98	M2250	Dark Grey	A0642804	Italy
NT3G30AA-35	Adjustable stand	Chameleon gray (ash)	A0348780	Global
NT3G30AA-98	Adjustable stand	BTS dark gray	A0348778	Global
NT7G10AA	Attendant Supervisory Module (ASM)	N/A	A0366221	Global

Features

The M2250 has the following features:

- A four-line, 40 character, liquid crystal display (LCD) with backlighting. Power, including backlighting, is maintained during building power failures with the system's battery backup, if equipped.
- Angle adjustment of the display screen, which can be tilted through 90° from horizontal to fully vertical.
- Scrolling control of lines 2 and 3 of the display screen.
- In Shift mode, the M2250 can have up to 20 Trunk Group Busy (TGB) keys.
- In Shift mode, the M2250 can have up to 10 extra flexible feature keys for a total of 20.
- An optional supporting stand that can be adjusted to nine different positions.

- A handset and headset volume slider control, situated below the dial pad.
- A physical connection to a serial data port through a subminiature D-type female connector on the console back wall. This permits connection of the console to the serial port of a personal computer.
- An optional Busy Lamp Field/Console Graphics Module (BLF/CGM), which displays the status of up to 150 consecutive extensions (SBLF) or any group of 100 extensions within the system (EBLF) and has many text and graphics capabilities.
- An optional Attendant Supervisory Module (ASM) can be installed.
- Supports transmission level adjustment to meet international requirements by accepting and processing downloaded information from the system (when this messaging is supported in software). The transmission level can be adjusted to one of 16 different levels.
- Multi-language selection.
- Menus for local console features (Options menu) and diagnostics (Diagnostics menu).
- Code blue or emergency relay (associated with ICI 0).
- Time and date system download.
- Alert tone volume and frequency selection.
- Electret or carbon transmitter support.
- Power Fail Transfer switch.
- Keyclick.

Busy Lamp Field/Console Graphics Module

The Busy Lamp Field/Console Graphics Module (BLF/CGM) can be added to an M2250 attendant console.

The BLF/CGM can do the following:

- display the status (busy or idle) of up to 150 consecutive extensions within the system Standard Busy Lamp Field (SBLF)
- display the status (busy or idle) of any hundred group of DNs within the system Enhanced Busy Lamp Field (EBLF)
- display which attendant console is the supervisory console and which consoles are active
- display supplementary information about individual extensions, such as the reason the person is away (business, vacation, or illness), when

the person is due to return, and an alternate extension where calls to the person should be directed

- display a company logo
- display graphics
- display text in any one of eight languages
- have its screen contrast adjusted for easy viewing

Power requirements

The BLF/CGM obtains its power through the attendant console. See [Figure 1 "Busy Lamp Field/Console Graphics Module on the M2250 attendant console" \(page 21\)](#). The requirements are as follows:

- a reference ground line (0 V)
- power source of 5 V for the CMOS electronics that control the Lamp Field Array module (c. 50 mA)
- power source of -12 V for the display of the Console Graphics Module (c. 10 mA)
- backlighting power

The BLF/CGM has a battery that provides backup power to maintain the Supplementary Information when the console is powered down. The battery lifetime is five years. To replace the battery, return the BLF/CGM to the supplier.

Installation

The BLF/CGM mounts on the back of the attendant console and is held on by snap-fits and screws. It is connected to the console using a 16-way connector that is located on the keyboard Printed Circuit Board (PCB). This connector is accessed through a rectangular knockout section located underneath the casing overhang at the Meridian logo location. The attendant console's top cover must be removed to install the BLF/CGM.

Refer to the following procedures to install the BLF/CGM:

- [Procedure 1 "Connecting the BLF/CGM to the M2250 attendant console" \(page 21\)](#)
- [Procedure 2 "Checking the functionality of the Busy Lamp Field/Console Graphics Module" \(page 27\)](#)
- [Procedure 3 "Removing the Busy Lamp Field/Console Graphics Module" \(page 28\)](#)

Refer to the *M1250/M2250 Attendant Console User Guide* () or the *Busy Lamp Field/Console Graphics Module User Guide* () for further information.

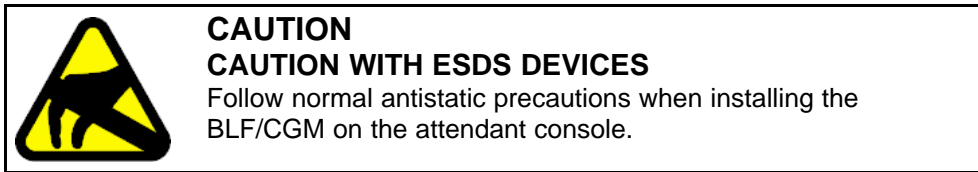
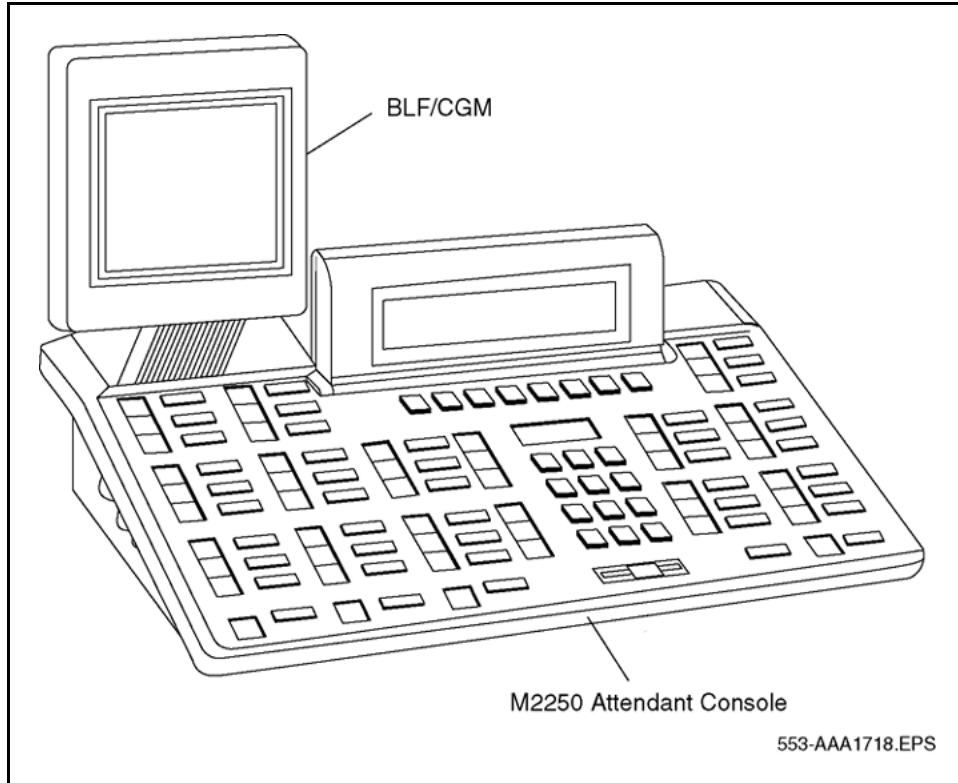

Figure 1
Busy Lamp Field/Console Graphics Module on the M2250 attendant console



Procedure 1
Connecting the BLF/CGM to the
M2250 attendant console

Step	Action
1	Disconnect the main power/system cable from the rear of the attendant console, and remove the handset jack plug from the side.
2	Move the adjustable display to the down position to protect it from damage while installing the BLF/CGM. Move the volume slider switch to the far left. See Figure 2 "Volume slider position" (page 22) .

Figure 2
Volume slider position

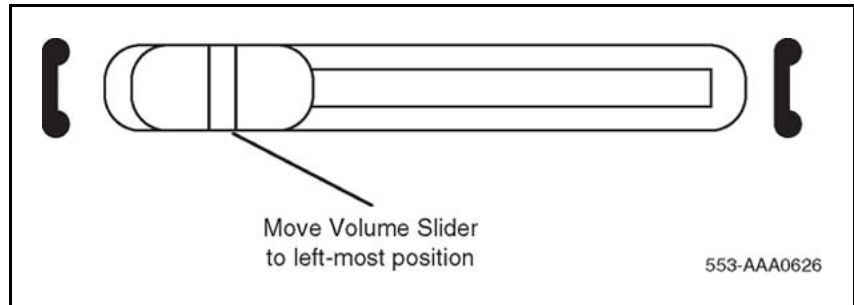

- 3 Place the attendant console facedown on a properly prepared work surface, taking care to avoid scratching or damaging the top cover or display. Remove the adjustable stand, if required.
The stand is secured with four screws. Remove the stand as a complete assembly, and set aside.
- 4 Remove the 12 fastening screws in the base of the attendant console that secure the top cover to the console base. See [Figure 3 "Removing the fastening screws" \(page 22\)](#). Holding the console base and cover firmly, turn it over so that the top cover is on, facing up.

Figure 3
Removing the fastening screws

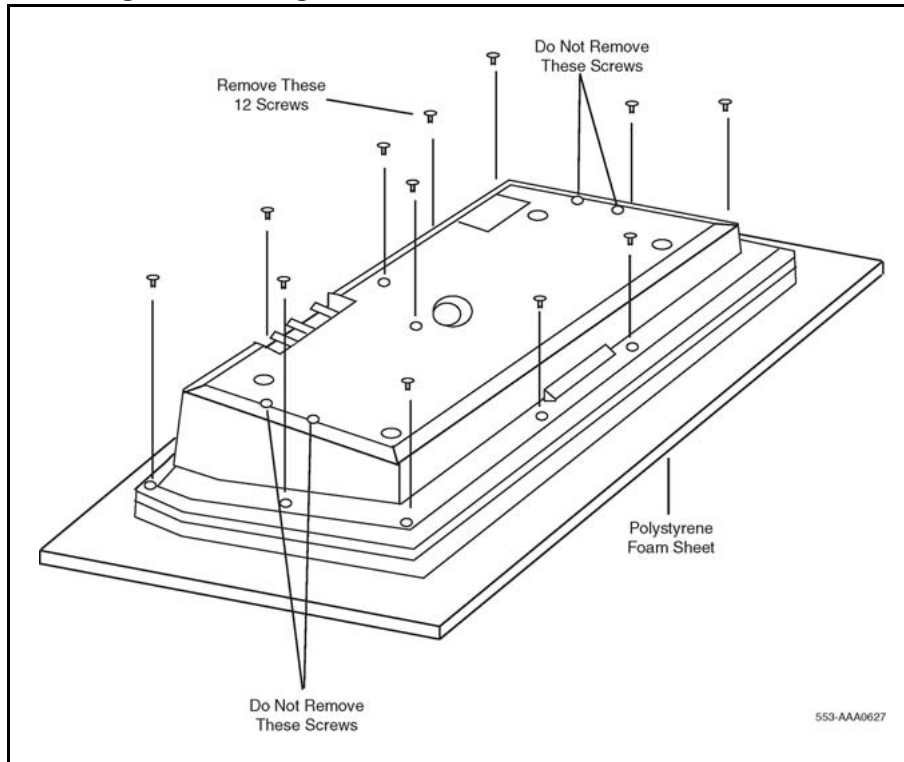

- 5 Raise and hold the top cover to remove the single cable connector only. The alerter cable does not need to be removed. See [Figure 4 "Removing the top cover"](#) (page 23).
- 6 Remove the top cover, and place it upside down to the left of the attendant console.

Figure 4
Removing the top cover

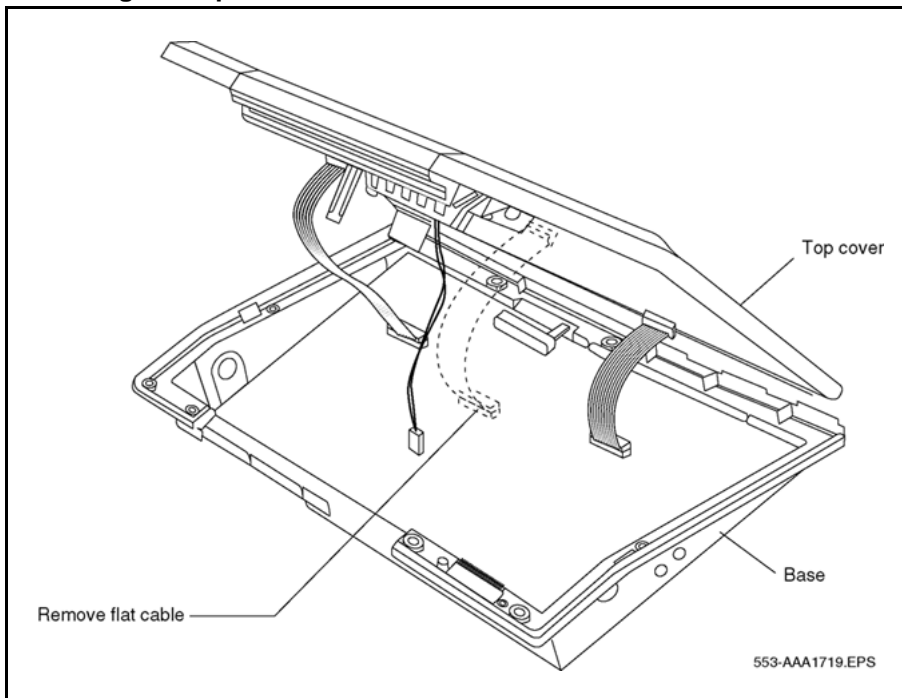

- 7 Remove the knockout section on the back of the attendant console (see [Figure 5 "Attendant console knockout section"](#) (page 24)) with a small screwdriver or similar tool. Remove any remnants of the breakaway tags.
- 8 Feed the flat ribbon cable for the Busy Lamp Field/Console Graphics Module (BLF/CGM) through the knockout hole in the base of the attendant console.
- 9 Hold the BLF/CGM unit over the console in a vertical position, ensuring that the two locators on the bottom bracket of the BLF/CGM are located in the knockout hole.

Figure 5
Attendant console knockout section

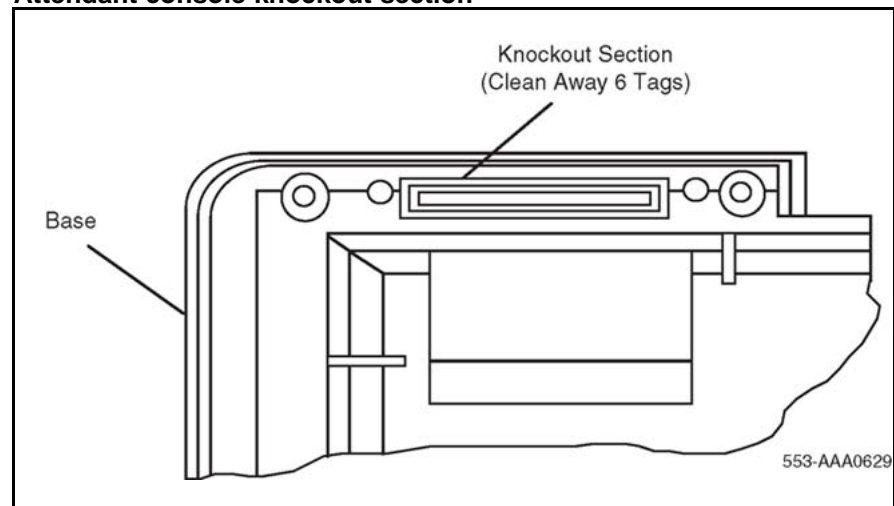

- 10 Push down on the attendant console, while holding the BLF/CGM unit, until the two locators snap into place. See [Figure 6 "Connecting the BLF/CGM to the attendant console" \(page 25\)](#) on [Figure 6 "Connecting the BLF/CGM to the attendant console" \(page 25\)](#).
- 11 Fit the BLF/CGM ribbon cable onto the top cover circuit board, into the flexible strip connector J4 (so that the blue line on the cable faces away from the circuit board).
- 12 Hold the top cover over the attendant console and reconnect the cable connector(s) onto the base of the attendant console.
- 13 Place the top cover on the console. Slide it back and down into place. See [Figure 7 "Positioning the top cover and the BLF/CGM" \(page 26\)](#) on [Figure 7 "Positioning the top cover and the BLF/CGM" \(page 26\)](#). Check that all the cables are in the correct positions and that none are trapped.
- 14 Push the BLF/CGM display into position by rotating it back (see [Figure 7 "Positioning the top cover and the BLF/CGM" \(page 26\)](#)).
- 15 Ensuring that the volume slider is fully engaged in the correct slider, hold the top cover and console base firmly together. Turn the assembly upside down. See [Figure 8 "Attaching the top cover to the attendant console base and BLF/CGM" \(page 27\)](#) on [Figure 8 "Attaching the top cover to the attendant console base and BLF/CGM" \(page 27\)](#).
- 16 Reinsert the 12 screws that secure the top cover to the console base and tighten.
- 17 Insert the two new screws supplied with the BLF/CGM that attach it to the base, and tighten. See [Figure 8 "Attaching the top cover to the attendant console base and BLF/CGM" \(page 27\)](#) on

Figure 8 "Attaching the top cover to the attendant console base and BLF/CGM" (page 27).

Figure 6
Connecting the BLF/CGM to the attendant console

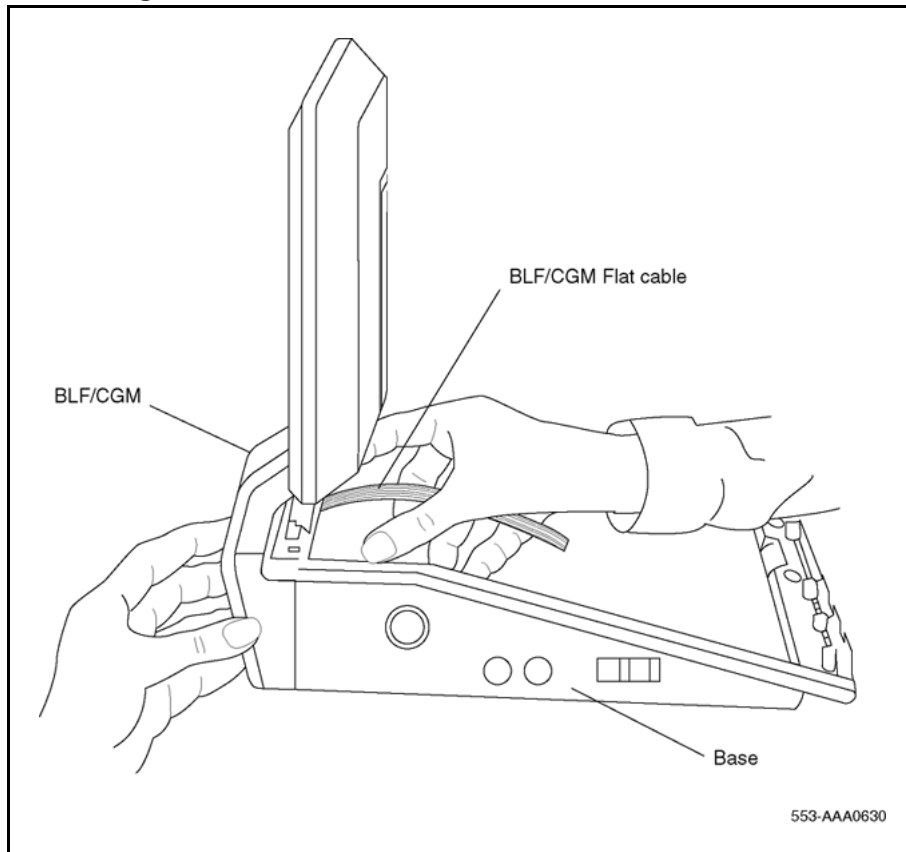

- 18** Cable in BLF power at the local Main Distribution Frame (MDF) as per M2250 cross-connections.
- 19** If required, replace the adjustable stand.
- 20** Reconnect the main system cable to the rear of the console.
- 21** If the BLF/CGM has been correctly installed, the main menu appears when power is supplied to the attendant console. Test the BLF/CGM by selecting a menu option. Refer to *Busy Lamp Field/Console Graphics Module User Guide* () for programming information.
- 22** Define the Busy Lamp Field in the system database. Refer to *Features and Services Fundamentals-Six Books (NN43001-106_B1-B6)* () .
- 23** Test the Busy Lamp Field features using *M1250/M2250 Attendant Console User Guide* () .

Figure 7
Positioning the top cover and the BLF/CGM

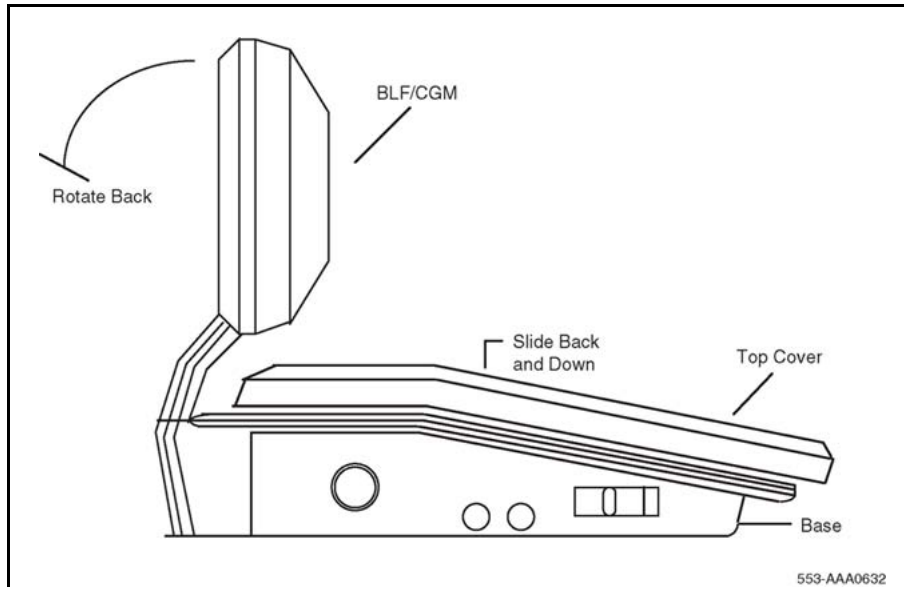
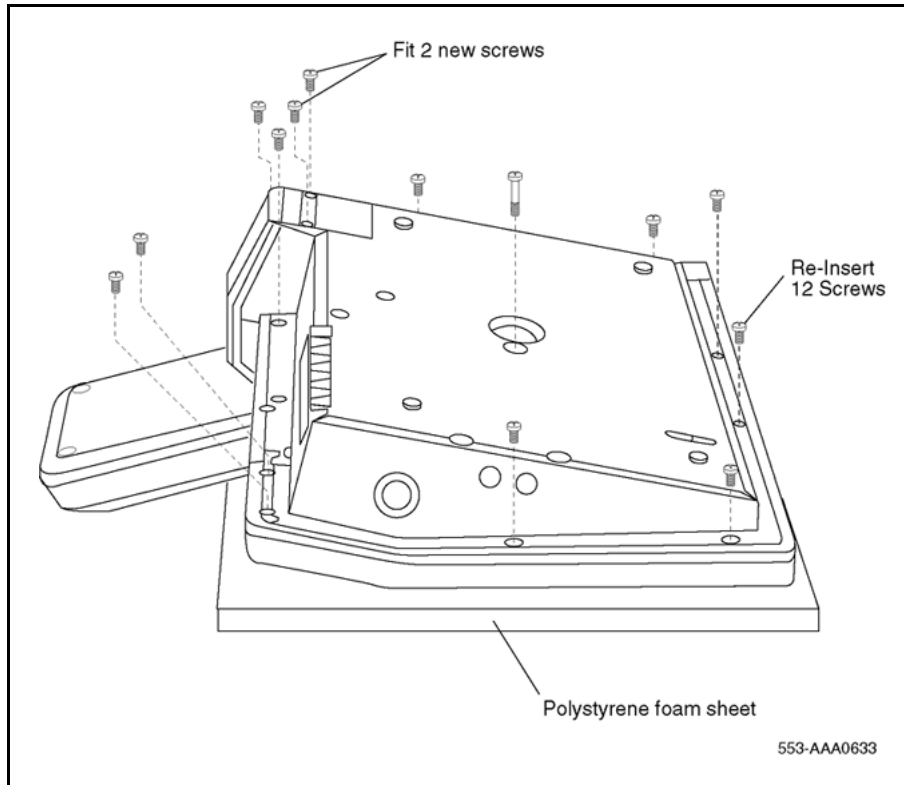

Figure 8
Attaching the top cover to the attendant console base and BLF/CGM



--End--

Procedure 2
Checking the functionality of the
Busy Lamp Field/Console Graphics Module

Step	Action
------	--------

Use this procedure to check the functionality of the BLF/CGM. Once in this menu, the dial pad is in CGM mode. When any dial pad keys are pressed, except the pound (#) key, the keys are echoed on the BLF/CGM.

- | | |
|---|---------------------------------------------------------------------------------------------------------|
| 1 | From Diagnostics menu 1, press 5. |
| 2 | Press keys 0 through 9 and the asterisk (*) on the dial pad. Check the CGM to see that they are echoed. |
| 3 | Press the pound (#) to exit and return to Diagnostics menu 1. |

--End--

Procedure 3
Removing the Busy Lamp
Field/Console Graphics Module

Step	Action
1	Disconnect the main power/system cable from the rear of the attendant console, and remove the handset jack plug from the side.
2	Move the adjustable display to the down position to protect it from damage while removing the BLF/CGM. Also move the volume slider switch to the far left (see Figure 2 "Volume slider position" (page 22)).
3	Place the attendant console facedown on a properly prepared work surface, taking care to avoid scratching or damaging the top cover or display. Remove the adjustable stand, if required. The stand is secured with four screws. Remove the stand as a complete assembly, and set it aside.
4	Remove the 12 fastening screws in the base of the attendant console that secure the top cover to the console base. See Figure 3 "Removing the fastening screws" (page 22) . Remove the two screws securing the BLF/CGM to the base of the attendant console.
5	Holding the console base and cover firmly, turn it back over so that the top cover is on, facing up.
6	Raise and hold the top cover to remove the single cable connector only. The alerter cable does not need to be removed (see Figure 4 "Removing the top cover" (page 23)).
7	Unplug the BLF/CGM ribbon cable from the attendant console.
8	Remove the top cover and place it upside down to the left of the attendant console.
9	Pull back the snap-fits on the BLF/CGM to disengage the BLF/CGM from the attendant console.
10	Place the top cover on the console. Slide it back and down into place (see Figure 7 "Positioning the top cover and the BLF/CGM" (page 26) on Figure 7 "Positioning the top cover and the BLF/CGM" (page 26)). Reconnect all cables in the correct positions, and make sure that none are trapped.
11	Ensuring that the volume slider is fully engaged in the correct slider, hold the top cover and console base firmly together. Turn the assembly upside down (see Figure 8 "Attaching the top cover to the attendant console base and BLF/CGM" (page 27) Figure

- 8 "Attaching the top cover to the attendant console base and BLF/CGM" (page 27)).
- 12 Reinsert the 12 screws that secure the top cover to the console base and tighten.
 - 13 If required, replace the adjustable stand.
 - 14 Reconnect the main system cable to the rear of the console.

--End--

For more on the features and operation of the BLF/CGM, refer to the *Busy Lamp Field/Console Graphics Module User Guide* () .

Display backlight power supply option

An optional 16 V DC power supply (A0367601) can be installed to the Main Distribution Frame(MDF) to improve the backlight brightness of the BLF/CGM display.

The display backlight power supply must be cabled in at the local MDF at a maximum of 120 ft (36 m) from the attendant console when the BLF/CGM is installed (A0367601 – Transformer). This provides all the power requirements for the M2250 applications.

DSS-9000 Direct Station Select/Busy Lamp Field

The DSS-9000 is a combined 150-lamp busy field and 150-button direct station select console that can be attached to an M2250 attendant console. The DSS-9000 emulates either a QMT-3 Busy Lamp Field array (standard Busy Lamp Field mode) or the Enhanced Busy Lamp Field Mode of a Console Graphics Module. For more information on DSS-9000 Direct Station Select/Busy Lamp Field, refer to the *DSS-9000 Direct Station Select/Busy Lamp Field User Guide* () .

Attendant Supervisory Module

A customer may wish to supervise an attendant console. To allow the M2250 to be supervised, an Attendant Supervisory Module (ASM) must be added. An attendant console configured as a supervisor does not need the ASM installed.

To accept the ASM, the minimum vintage M2250 attendant console is M2250AD. To fully support the ASM, the minimum vintage BLF/CGM is AB. The third PWR TN must be programmed and wired out to support the ASM. See [Figure 17 "M2250 attendant console cross-connections"](#) (page 53).

Follow the steps in [Procedure 4 "Installing an Attendant Supervisory Module on an M2250 attendant console"](#) (page 30) to install an ASM on an M2250 attendant console.

Procedure 4
Installing an Attendant Supervisory Module
on an M2250 attendant console



CAUTION
CAUTION WITH ESDS DEVICES
Damage to Equipment

Before handling internal set components, discharge static electricity from hands and tools by touching any grounded metal surface or conductor.

Step	Action
1	Disconnect the main power/system cable from the rear of the attendant console, and remove the handset jack plug from the side.
2	Move the adjustable display to the down position to protect it from damage while installing the ASM. Move the volume slider switch to the left-most position.
3	Place the attendant console facedown on a properly prepared work surface, taking care to avoid scratching or damaging the top cover or display. Remove the adjustable stand, if equipped. The stand is secured with four screws. Loosen the screws and remove the stand as a complete assembly, and set aside.
4	Remove the 12 fastening screws in the base of the attendant console that secure the top cover to the console base (see Figure 3 "Removing the fastening screws" (page 22)). Holding the console base and cover firmly, turn it back over so that the top cover is on, facing up.
5	Raise and hold the top cover to remove the single cable connector. The alerter cable does not need to be removed (see Figure 4 "Removing the top cover" (page 23)). Remove the top cover and place it upside down to the left of the attendant console.
6	Holes are located in the upper right-hand side of the attendant console's main PCB, near grid positions D1, D5, and A5. See Figure 9 "Identifying the correct grid positions on the main PCB and attaching the ASM" (page 32) on Figure 9 "Identifying the correct grid positions on the main PCB and attaching the ASM" (page 32) . Insert one standoff in each of the holes, twisting it until it is secure.

**CAUTION****Damage to Equipment**

Once a standoff is inserted, it cannot be removed. Be sure to place each standoff in the correct hole on the main PCB, as shown in [Figure 9 "Identifying the correct grid positions on the main PCB and attaching the ASM" \(page 32\)](#) on [Figure 9 "Identifying the correct grid positions on the main PCB and attaching the ASM" \(page 32\)](#).

- 7 Position the ASM board over the J3 connector on the console's main PCB. Align the holes on the ASM board with the standoffs, and carefully work the ASM pin connector onto connector J3 until firmly seated. See [Figure 9 "Identifying the correct grid positions on the main PCB and attaching the ASM" \(page 32\)](#) on [Figure 9 "Identifying the correct grid positions on the main PCB and attaching the ASM" \(page 32\)](#).
- 8 Hold the top cover over the attendant console, and reconnect the cable connector onto the base of the console.
- 9 Place the top cover on the console. Slide it back and down into place. Check that all the cables are in the correct positions, and that none are trapped.
- 10 Ensure that the volume switch is fully engaged in the correct slider. Hold the top cover and console base firmly together. Turn the assembly upside down.
- 11 Reinsert the 12 screws that secure the top cover to the console base and tighten.
- 12 If required, replace the adjustable stand.
- 13 Reconnect the main system cable to the rear of the console.
- 14 Test the supervisory console feature to make sure you can now properly supervise the M2250 attendant console. Refer to *M1250/M2250 Attendant Console User Guide* () .

--End--

Figure 9
Identifying the correct grid positions on the main PCB and attaching the ASM

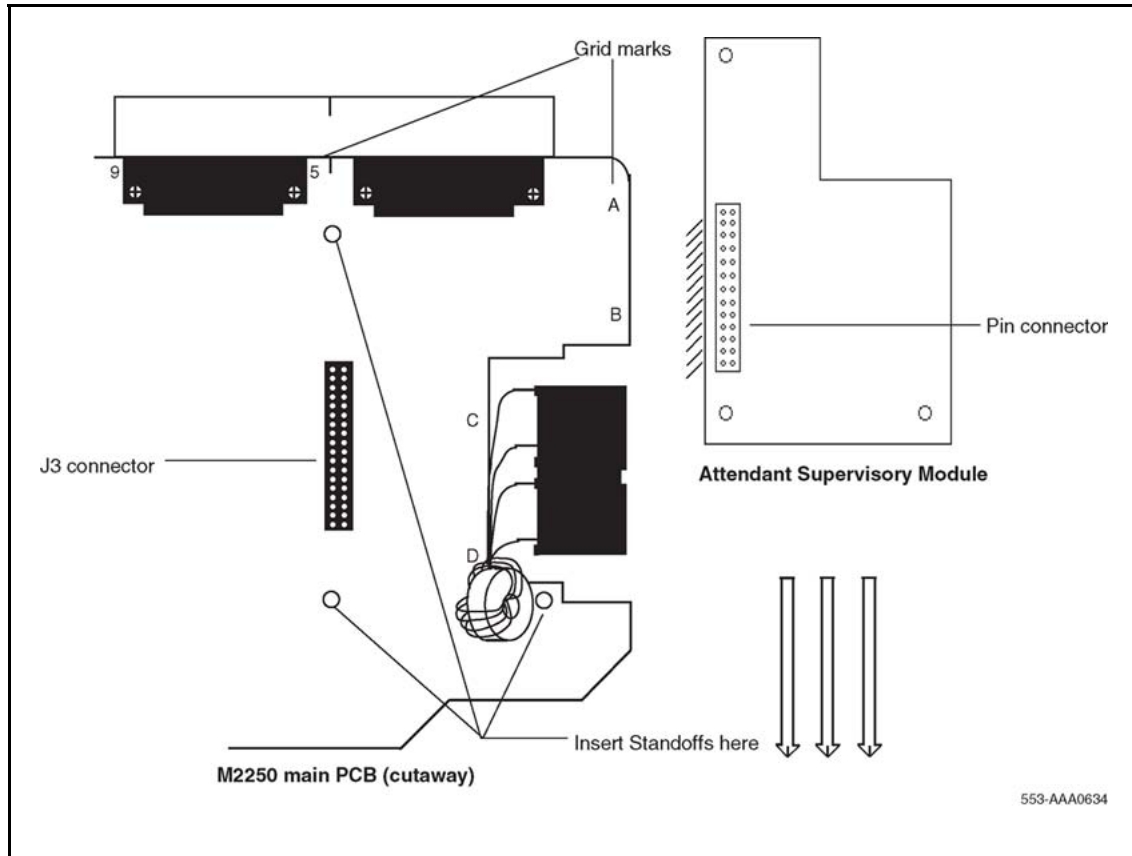

Physical description

Figure 10 "M2250 attendant console, top view" (page 34) on Figure 10 "M2250 attendant console, top view" (page 34) shows a top view of the M2250 attendant console layout. The user-accessible components are labeled using a row/column grid arrangement. Figure 11 "M2250 attendant console, rear, left side, and bottom views" (page 35) on Figure 11 "M2250 attendant console, rear, left side, and bottom views" (page 35) shows rear, left side, and bottom views of the console. These illustrations show where to find the various components.

Dimensions

Dimensions of the M2250 attendant console are as follows:

Table 3
Dimensions

Width	425 mm (16.75 in.)
Depth	245 mm (9.6 in.)

Table 3
Dimensions (cont'd.)

Height (front)	25 mm (1 in.)
Height (back)	65 mm (2.5 in.)
Height (with display screen panel up)	115 mm (4.5 in.)
Weight	approximately 2.75 kg (6 lbs)

Figure 10
M2250 attendant console, top view

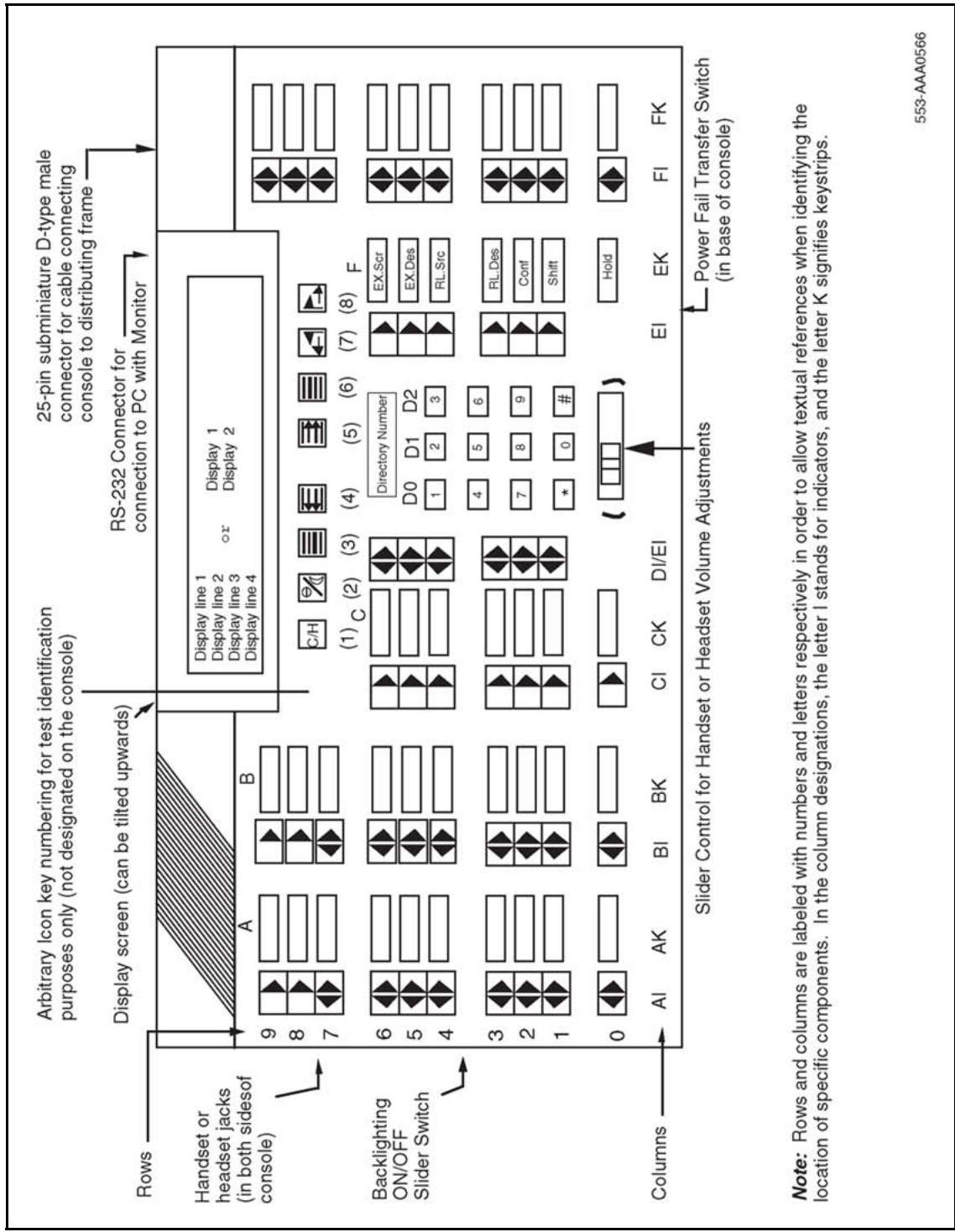

Note: Rows and columns are labeled with numbers and letters respectively in order to allow textual references when identifying the location of specific components. In the column designations, the letter I stands for indicators, and the letter K signifies keystrips.

553-AAA0566

Figure 11
M2250 attendant console, rear, left side, and bottom views

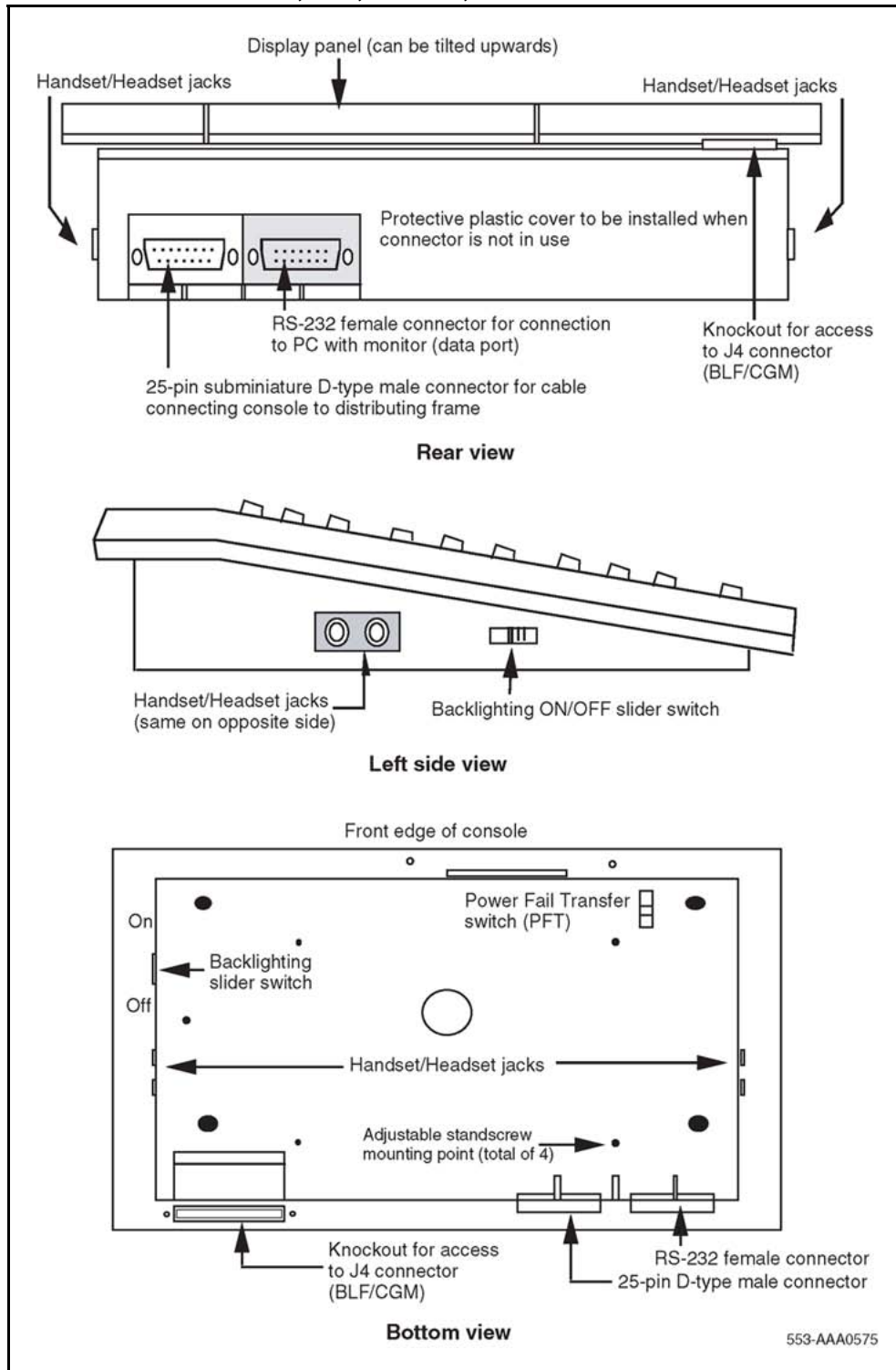

Keyboard layout

Refer to [Table 4 "Softkey definitions and functions" \(page 36\)](#) for the description of keys and [Figure 10 "M2250 attendant console, top view" \(page 34\)](#) and [Figure 11 "M2250 attendant console, rear, left side, and bottom views" \(page 35\)](#) for the location of switches and keys mentioned in this section.

Function keys

The attendant console has eight function keys, located directly below the display screen. Refer to [Table 4 "Softkey definitions and functions" \(page 36\)](#) for the positions, functions, and markings of these keys. For an explanation of the functions assigned to the other attendant console keys, refer to ["Operation" \(page 57\)](#).

Table 4
Softkey definitions and functions



Key number (see Figure 10 "M2250 attendant console, top view" (page 34))	Symbol	Function
(1)		Centralized Attendant Service (CAS) File
(2)		Prime function (normal): Position Busy feature Level 1 function (Shift): Night Service feature
(3)		Prime function (normal): Selects display screen line 2 for scrolling. Level 1 function (Shift): Selects the Options menu on the display screen. Alternating between the idle and active call display. From the idle display, press this key to show the active call display.

Table 4
Softkey definitions and functions (cont'd.)

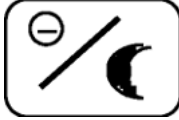

Key number (see Figure 10 "M2250 attendant console, top view" (page 34))	Symbol	Function
(4)		<p>Prime function (normal): Scrolls the currently selected line to the left.</p> <p>Level 1 function (Shift): Decreases the alert speaker volume.</p>
(5)		<p>Prime function (normal): Scrolls the currently selected line to the right.</p> <p>Level 1 function (Shift): Increases the alert speaker volume.</p>
(6)		<p>Prime function (normal): Selects line 3 on display screen for scrolling.</p> <p>Level 1 function (Shift): Selects the Diagnostics menu on the display screen. The Diagnostics menu is password-protected. To display it, the user must enter a 4-digit password and press * on the dial pad.</p> <p>Alternating between the idle and active call display. From the active call display, press this key to show the idle display.</p>

Table 4
Softkey definitions and functions (cont'd.)

Key number (see Figure 10 "M2250 attendant console, top view" (page 34))	Symbol	Function
(7)		<p>Prime function (normal): Signal Source feature key</p> <p>Level 1 function (Shift and Conf/Busy Lamp Field key): Used with the Busy Lamp Field/Console Graphics Module, as CGM key.</p>
(8)		<p>Prime function (normal): Signal Destination feature key</p> <p>Level 1 function (Shift): Used with the Busy Lamp Field/Console Graphics Module, as the Mode key.</p>

Switches

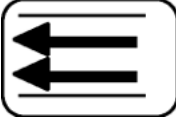
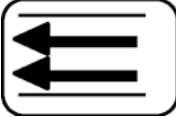
A slider control, located below the dial pad, between columns DI/EI and FI, controls the handset and headset receive volume level. See [Figure 10 "M2250 attendant console, top view" \(page 34\)](#) on [Figure 10 "M2250 attendant console, top view" \(page 34\)](#).

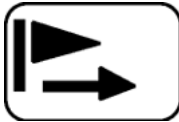
A Power Fail Transfer (PFT) switch is located in the baseplate. See [Figure 11 "M2250 attendant console, rear, left side, and bottom views" \(page 35\)](#) on [Figure 11 "M2250 attendant console, rear, left side, and bottom views" \(page 35\)](#). Both the line connector and the RS-232 connector for the PC port are located at the back of the console.

Shift key

The Shift key is positioned in column FK, row 1, just above the Hold key. See [Figure 10 "M2250 attendant console, top view" \(page 34\)](#) on [Figure 10 "M2250 attendant console, top view" \(page 34\)](#). It is used to access Level 1 mode functions.

Handset and headset jacks

Two pairs of jacks are provided for plugging in handsets or headsets. The jacks are located on both sides of the console beneath the faceplate in the recessed area shown by the arrows. See [Figure 10 "M2250 attendant](#)

console, top view" (page 34) on Figure 10 "M2250 attendant console, top view" (page 34). The console accepts both carbon and electret handsets or headsets and automatically adapts itself to each type.

Note: Electret headsets and handsets are polarity sensitive and must be correctly inserted into the jack.

LCD indicators

The LCD indicators on the M2250 display triangular symbols that normally point towards the key with which they are associated. Certain keys in the QMT2 mode of operation and loop keys have two LCDs associated with each key instead of one.

Every LCD can flash at 30, 60, or 120 impulses per minute (ipm). Refer to "Operation" (page 57) for more details.

The M2250 attendant console has 10 additional flexible features. These are programmed in LD 12 and accessed using the **Shift** key.

Display screen messages

Source information appears on line 2 of the display screen. Destination information appears on line 3 of the display screen.

The status messages listed below appear on line 4 of the display screen panel.

— MN	(minor alarm)
— MJ	(major alarm)
— C/H	(CAS/History File)
— CW	(Call Waiting)
— BUSY	(Position Busy)
— NIGHT	(Night Service)
— IDLE	(Idle)
— ACTIVE	(lpk has been selected)
— S	(Shift mode)
— EMERGENCY	(Power Fail Transfer (PFT) feature is activated.)

The first four status messages appear as MN, MJ, C/H, and CW on line 4 of the display screen panel. BUSY and NIGHT are combined with the status of the Release lamp to indicate the console status as shown in Table 5 "Release lamp indicator status" (page 40).

Table 5
Release lamp indicator status

Type	Indicator	Status	
Night	Busy	Release	Display screen status (line 4)
ON	X	X	NIGHT
OFF	ON	X	BUSY
OFF	OFF	ON	IDLE
OFF	OFF	OFF	ACTIVE
X	X	X	EMERGENCY

If the emergency power fail transfer feature is activated, the console status will be displayed as EMERGENCY.

Connections

The line cord connects to the rear of the M2250 attendant console through a 25-pin subminiature D-type connector. The jack connector is attached to the line cord for user safety and equipment protection (pins are not exposed). Having the plug connector mounted in the console also prevents interchanges between the line cord and the serial data port connectors (the serial data port in the console has a jack connector).

Identical two-prong G3 type connectors are provided on each side of the console body to permit handset or headset connection at either side of the console. The M2250 attendant console is compatible with both carbon and electret handsets or headsets. The electret handset plug is orientation-dependent and is labeled accordingly.

The attendant console is connected to the system through two digital ports –one port for Call Service processing and one for Call Destination processing – with three additional ports for powering, for a total of five ports. The PCCIU interface used for the PC-based Console software application requires only three ports in total.

The attendant console requires a Digital Line Card (DLC) or an Integrated Services Digital Line Card (ISDLC) NT8D02 or later.

Local console controls

Visual contrast on the display panel can be adjusted using the Contrast option on the **Options** menu.

From the **Options** menu, four-line mode can be changed to two-line mode for easier viewing and to use larger fonts.

The pitch and volume of the buzz tone on the console can be adjusted by the user.

Any one of 15 languages can be chosen for the console screen displays: English, French, Spanish, German, Italian, Norwegian, Irish (Gaeilge),

Turkish, Katakana, P.R.C. (People's Republic of China), Taiwan, Korean, Polish, Czech/Slovak, or Hungarian.

When the languages P.R.C., Taiwanese, and Korean are chosen, the attendant console uses two-line display.

The attendant console is equipped with a real-time clock/calendar. The time of day (hours, minutes, and seconds) and the date (day, month, and year) are displayed on line 1 of the display screen.

The sound of key clicks can be turned on or off. The pitch and volume of key clicks can be adjusted.

Wiring

The M2250 attendant console requires a 16-pair cable terminated on an Amphenol connector.

When zone cabling and conduit are used, assign a block of numbers or letters to each zone. Allow for growth when assigning blocks of numbers.

Cable markers are normally an adhesive-backed cloth tape 1/2 inches wide by 3-1/2 inches long (15 mm by 65 mm) with preprinted numbers.

For limits and cabling for analog (500/2500-type) telephones, refer to [Figure 12 "Zone cabling and conduit assignment" \(page 42\)](#).

For a list of terminal connections, see [Table 6 "Terminal connections" \(page 43\)](#) on [Table 6 "Terminal connections" \(page 43\)](#).

Installing wiring

Follow the steps in [Procedure 5 "Installing wiring" \(page 41\)](#) to install the wiring for a telephone.

Procedure 5 Installing wiring

Step	Action
1	Assign a number to the wire or cable used.
2	Attach the assigned number to the wire or cable at the end nearest the telephone, using a cable marker.
3	Run the wire or cable between the telephone location and nearest cross-connect point (if not previously run).

- 4 Connect the cable or wire to the telephone connecting block.
- 5 Designate the telephone connecting block.

Figure 12
Zone cabling and conduit assignment

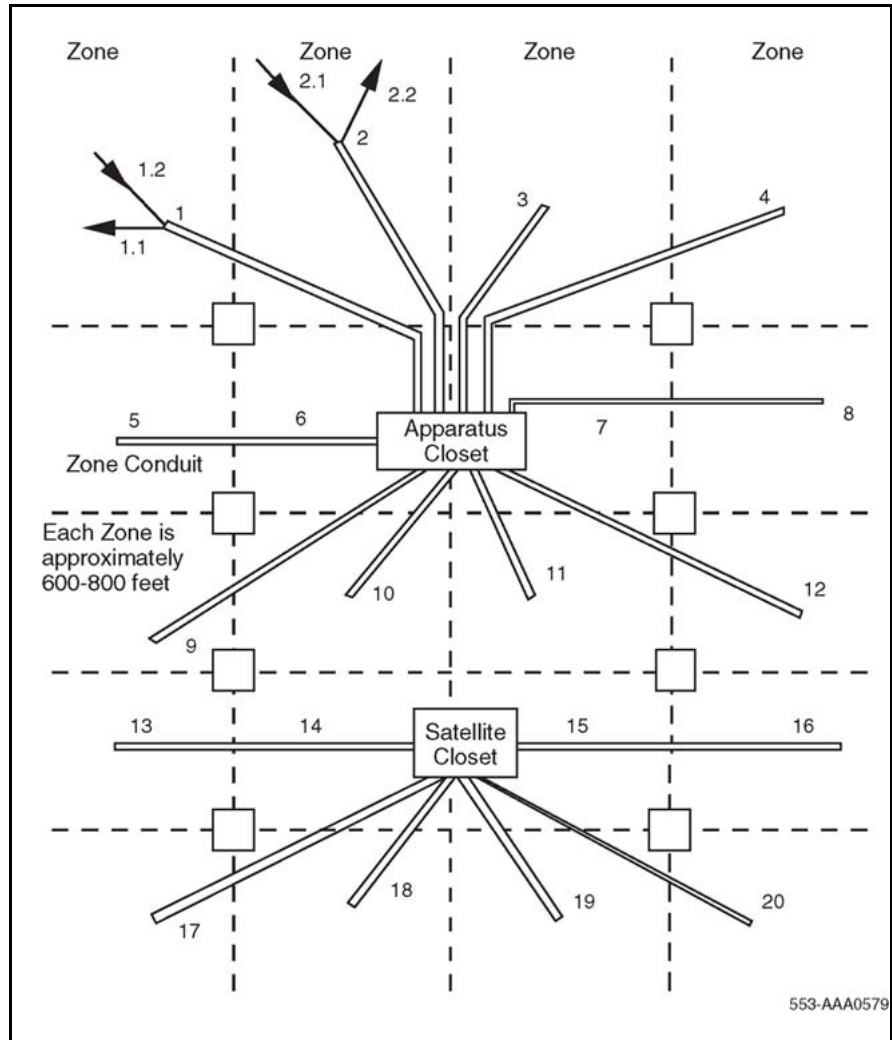

- 6 Cross-connect the pairs at intermediate cross-connect points (if required) and terminate at the cross-connect terminal.
- 7 Terminate leads at the cross-connect terminal and designate the blocks according to the house cable plan.

--End--

Table 6
Terminal connections

Connecting block Designations			Inside wiring Colors	
NE-47QA or QBB1B	NE-284-74-500 1 adapter	NE-625F TELADAPT plugs and jacks	Z station wire	16/25-pair cable
G	1T	T1 (G)	G	W-BL
R	1R	R1 (R)	R	BL-W
BK	X1	AUX (BK)	BK	W-O
Y	X2	GND (Y)	Y	O-W
5	R	T2 (BL)		W-SL
6	B	R2 (W)		SL-W

Normal operating ranges

The M2250 attendant console has a maximum permissible loop length of 3500 ft (915 m), assuming 24 AWG (0.5 mm) wire with no bridge taps. A 15.5 dB loss at 256 kHz defines the loop length limit.

Installation

This section provides installation instructions for the M2250 attendant console. For Attendant PC Software installation instructions, refer to *Meridian 1 Attendant PC: Software Installation Guide* ().

Packing and unpacking

Use proper care while unpacking the M2250 attendant console. Check for damaged containers so that appropriate claims can be made to the transport company for items damaged in transit.

If an attendant console must be returned to the factory, pack it in the appropriate container to avoid damage during transit. Remember to include all loose parts (cords, handset, power unit, labels, and lenses) in the shipment.

Installation and removal

Use the following procedures to install and remove M2250 attendant consoles.

Note: Although M2250 attendant consoles do not require a static discharge ground connection, the connection should be installed to protect any earlier vintage attendant consoles that may be used as replacements.

Choose a clean, level work surface and place several sheets of soft, clean paper between the attendant console and the work surface. This will prevent scratching or otherwise damaging the top cover, LCD indicators and screen, and the feature keys of the attendant console.

Installing the M2250 attendant console

Follow the steps in [Procedure 6 “Installing the M2250 attendant console” \(page 44\)](#) to install the M2250 attendant console.

Procedure 6 Installing the M2250 attendant console

Step	Action
1	Ensure that a 16-pair or 25-pair cable equipped with a 25-pair Amphenol connector is installed at the attendant console's location.
2	Unpack and inspect the attendant console for damage. If the console is damaged, notify the supplier.
3	Designate the console according to the features provided.
4	Connect the Amphenol plug on the attendant console to the Amphenol jack coming from the Main Distribution Frame (MDF). <ol style="list-style-type: none"> a Fasten the Amphenol connectors together and secure the captive screws on the cable. b Ensure that the connectors are secured in a connector mounting, if provided, or to the wall. Do not leave connectors unprotected on the floor.
5	Add a line circuit for the attendant console, if not already done. Refer to <i>Circuit Card Reference (NN43001-311) ()</i> .
6	Cross-connect the attendant console at the cross-connect terminal. See Procedure 12 “Cross-connecting attendant consoles” (page 51) on Procedure 12 “Cross-connecting attendant consoles” (page 51) .
7	Enter the related attendant console data in the system. Refer to <i>Software Input Output Administration (NN43001-611) ()</i> .
8	Test the console features using the attendant console user guide.

Note: Refer to *Circuit Card Reference (NN43001-311) ()* for circuit card installation procedures.

--End--

Removing the M2250 attendant console

Follow the steps in [Procedure 7 “Removing the M2250 attendant console” \(page 45\)](#) if it is necessary to remove an M2250 attendant console.

Procedure 7 Removing the M2250 attendant console

Step	Action
1	Remove related attendant console data from the system memory. Refer to the <i>Software Input Output Administration (NN43001-611)</i> ().
2	Locate and remove cross-connections from the attendant console cable at the cross-connect terminal. See Procedure 12 “Cross-connecting attendant consoles” (page 51) on Procedure 12 “Cross-connecting attendant consoles” (page 51) .
3	Remove the circuit card if required. Refer to <i>Circuit Card Reference (NN43001-311)</i> ().
	Note: Do not remove the circuit card if any of the remaining units on the card are assigned.
4	Disconnect the Amphenol connector on the end of the cable leading to the cross-connect terminal from the connector on the cable leading to the attendant console.
5	Pack the attendant console, handset, and cords in a suitable container.
--End--	

Removing the M2250 attendant console top cover

Follow the steps in [Procedure 8 “Removing the M2250 attendant console top cover” \(page 45\)](#) to remove the M2250 Attendant top cover.

Procedure 8 Removing the M2250 attendant console top cover

Step	Action
1	Disconnect any plugs and cords from the attendant console.
2	Remove the ten 10-mm fastening screws in the flange of the attendant console, as well as one 10-mm and one 40-mm screw on the base of the attendant console. See Figure 13 “M2250 assembly drawing (exploded view)” (page 46) for the M2250 assembly drawing.

Figure 13
M2250 assembly drawing (exploded view)

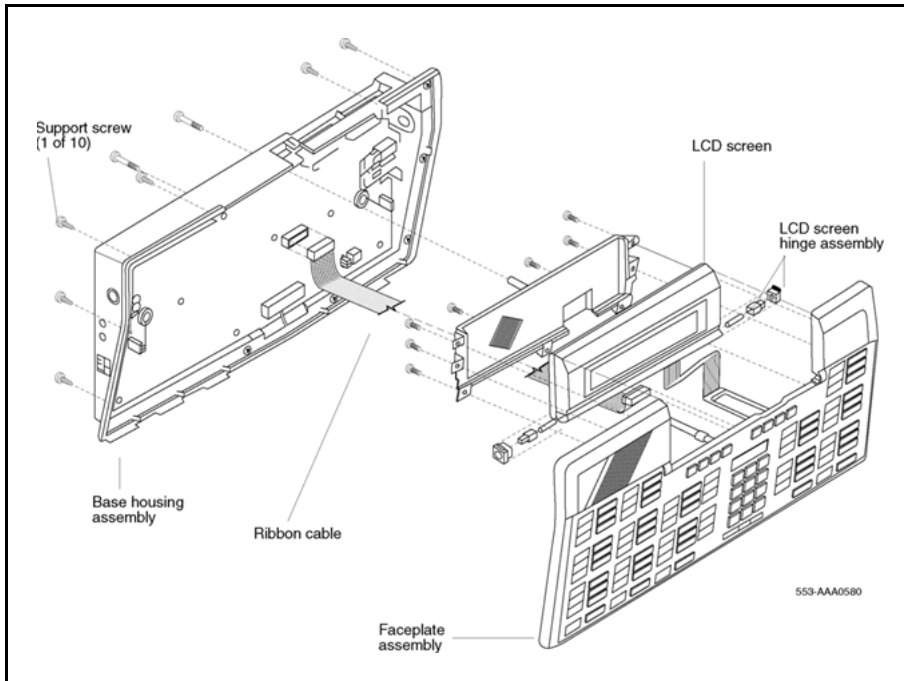

- 3** Holding the top cover and the base together by hand, turn the attendant console right-side up and place it back on the work surface.
- 4** Carefully lift the faceplate straight up and disconnect the 20-pin plug ribbon cable located at J2.

Note: On attendant consoles with a display attached to the top cover, do not connect or disconnect the cable to the display unless the attendant console line cord is disconnected.

--End--

Installing the M2250 attendant console top cover

Follow the steps in [Procedure 9 "Installing the M2250 attendant console top cover"](#) (page 46) to install the M2250 attendant console top cover.

Procedure 9 Installing the M2250 attendant console top cover

Step	Action
1	Set the QMT2 dip switch. To locate the dip switch, look at the attendant console from the top. The QMT2 dip switch is the only

dip switch on the topmost circuit board. Set the switch to ON (enable QMT2) or OFF (disable QMT2).

Note: The QMT2 feature must be enabled in system software. Refer to LD 12 in *Software Input Output Administration (NN43001-611)* ().

- 2 Carefully lift the top cover straight up and connect the 20-pin plug ribbon cable to J2.
- 3 Put the top cover back on the attendant console:
 - a Place the top cover onto the base housing, and turn the attendant console upside down.
 - b Reinsert and tighten the ten 10-mm fastening screws on the flange.
 - c Reinsert and tighten one 10-mm and one 40-mm fastening screw on the back.
- 4 Return the attendant console to its working position, reconnect the plugs and cords, and test the features.

--End--

Performing a loopback test

Follow the steps in [Procedure 10 “Performing a loopback test on the M2250 attendant console” \(page 47\)](#) to perform a loopback test on the M2250 attendant console.

Procedure 10 Performing a loopback test on the M2250 attendant console

Step	Action
1	Make a loopback connector. Prepare a blank 25-way RS-232 plug by internally connecting pins 2 and 3 together with strapping wire.
2	Press the Shift key to access Level 1 mode.
3	Press the F4 (function) key to access the Diagnostics menu on the LCD screen.
4	Plug the loopback connector into the Data Port RS-232 jack in the back of the console.
5	Select the Data Port option from the Diagnostics menu by dialing 3 . The LCD screen displays OK when the test is successfully completed.
	If there is a hardware fault on the M2250, A0H is displayed.

- If the blank RS-232 connector is not plugged into the data port correctly (as described in Step 4), the display reads 90H or A0H.
- 6 Press the asterisk (*) key to repeat the test.
 - 7 To exit the test mode press the octothorpe (#). to return to the main Diagnostics menu.
 - 8 Press the octothorpe (#) to return to normal operating mode.
 - 9 Remove the loopback connector from the Data Port RS-232 jack.

--End--

Designating keys on the M2250 attendant console

Refer to the work order to determine the features and key designations for each attendant console. Designate each key on the attendant console by placing its feature name (from the designation sheet) in the key cap that fits on the key.

The Directory Number (DN) designation window on the attendant console is located above the keypad.

Follow the steps in [Procedure 11 "Designating keys on an M2250 attendant console"](#) (page 48) to designate keys on an M2250 attendant console.

Procedure 11 Designating keys on an M2250 attendant console

Step	Action
1	Remove the cap from each key requiring a designation by gently pulling upward on the cap.
2	Remove the appropriate designation from the sheet of designations.
3	Place the designation in the cap, place the cap over the corresponding key, and gently press down. Repeat this procedure for all keys requiring a designation.
4	Insert a paper clip in the hole at the left or right end of the DN designation window. Pry the window open.
5	Insert the number tag, and replace the designation window.

--End--

The following figures show the typical key designations for the M2250 attendant console:

- Figure 14 "M2250 key designations in Shift mode (QMT2 not enabled)" (page 49) shows the key designations for the M2250 attendant console in Shift mode.
- Figure 15 "M2250 key designations in Unshift mode (QMT2 enabled)" (page 50) and Figure 16 "M2250 designations in Unshift mode (QMT2 not enabled)" (page 51) show the M2250 attendant console in Unshift mode.

Figure 14
M2250 key designations in Shift mode (QMT2 not enabled)

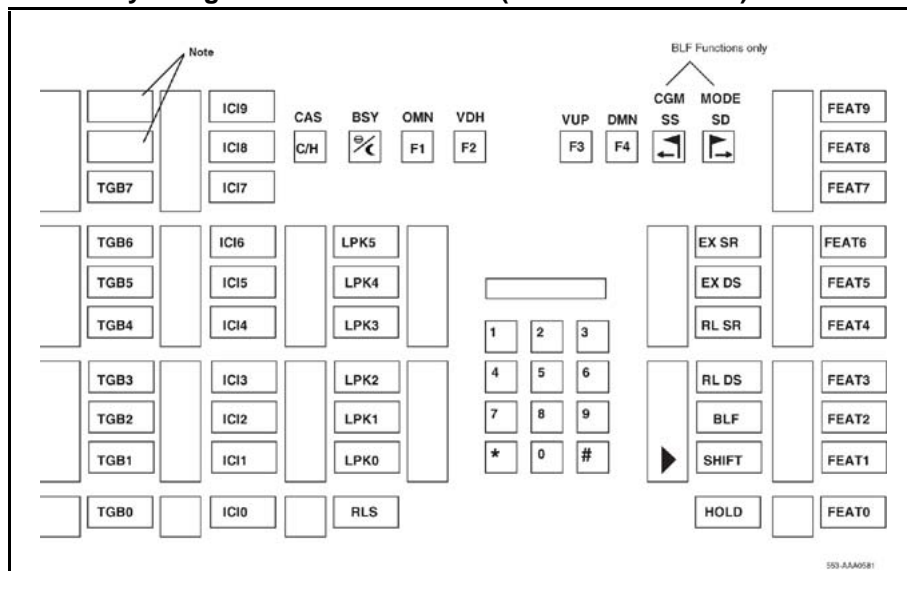

Figure 15
M2250 key designations in Unshift mode (QMT2 enabled)

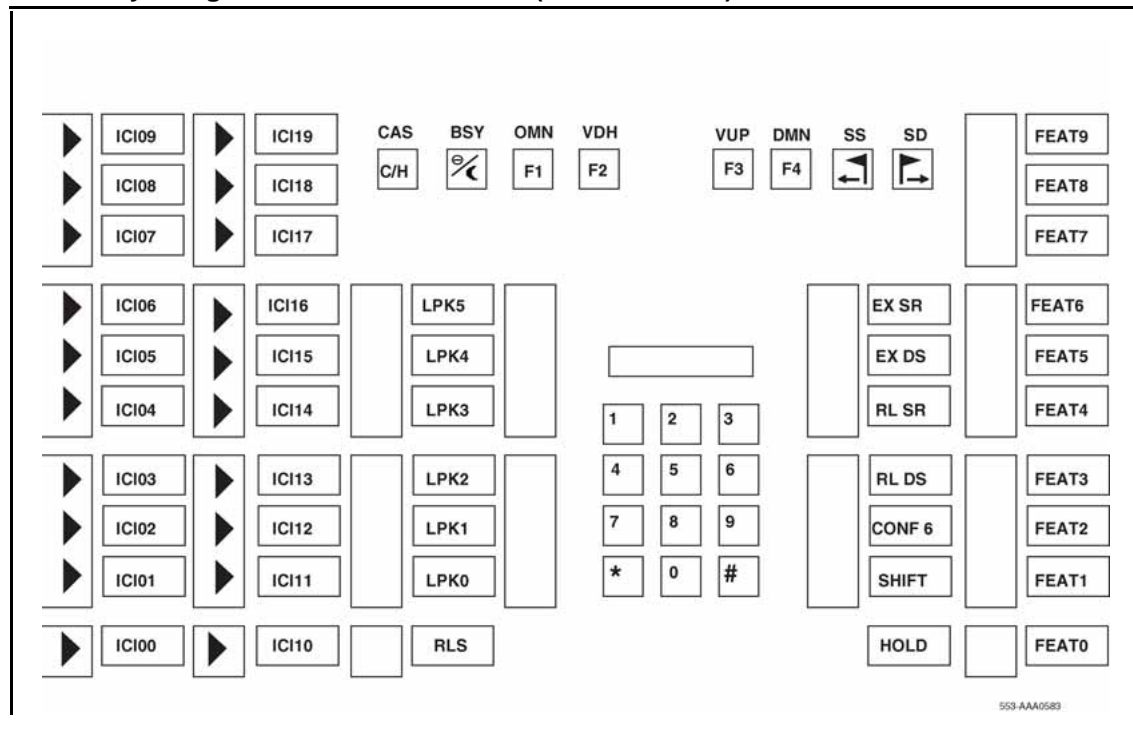
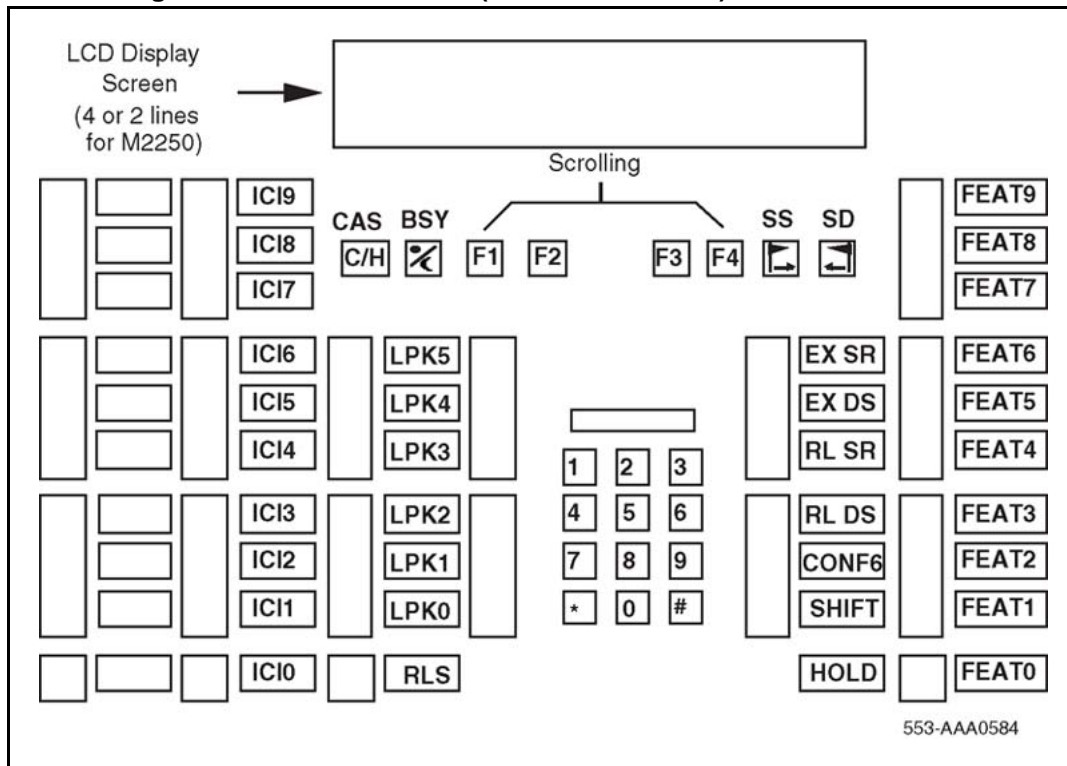

Figure 16
M2250 designations in Unshift mode (QMT2 not enabled)



Cross-connecting attendant consoles

Terminations are located on the vertical side of the distributing frame when frame-mounted blocks are used and located in the blue field when wall-mounted blocks are used.

Line circuit card (TN) terminations are located on the horizontal side of the distributing frame when frame-mounted blocks are used and located in the white field and wall-mounted blocks are used.

Follow the steps in [Procedure 12 “Cross-connecting attendant consoles” \(page 51\)](#) to cross-connect attendant consoles.

Procedure 12
Cross-connecting attendant consoles

Step	Action
1	Locate the attendant console terminations at the cross-connect terminal.

- 2 Connect Z-type cross-connecting wire to the leads of the attendant console.
- 3 Locate the line circuit card (TN) terminations.
- 4 Run and connect the other end of the cross-connecting wire to the assigned TN terminal block.

--End--

Refer to [Table 7 "Z-type cross-connecting wire" \(page 52\)](#) for details on Z-type cross-connecting wire and [Table 8 "Inside wiring colors" \(page 52\)](#) for a list of inside wiring colors.

Table 7
Z-type cross-connecting wire

Size	Gauge	Color	Designation
1 pr	24	Y-BL	Tip
		BL-Y	Ring
3 pr	24	W-BL	Voice T
		BL-W	Voice R
		W-O	Signal T
		O-W	Signal R
		W-G	Power
		G-W	Power

Table 8
Inside wiring colors

Z station wire	16/25-pair cable	Connect to equipment TN
G	W-BL	First pair Tip
R	BL-W	First pair Ring
BK	W-O	Second pair Tip
Y	O-W	Second pair Ring

Figure 17
M2250 attendant console cross-connections

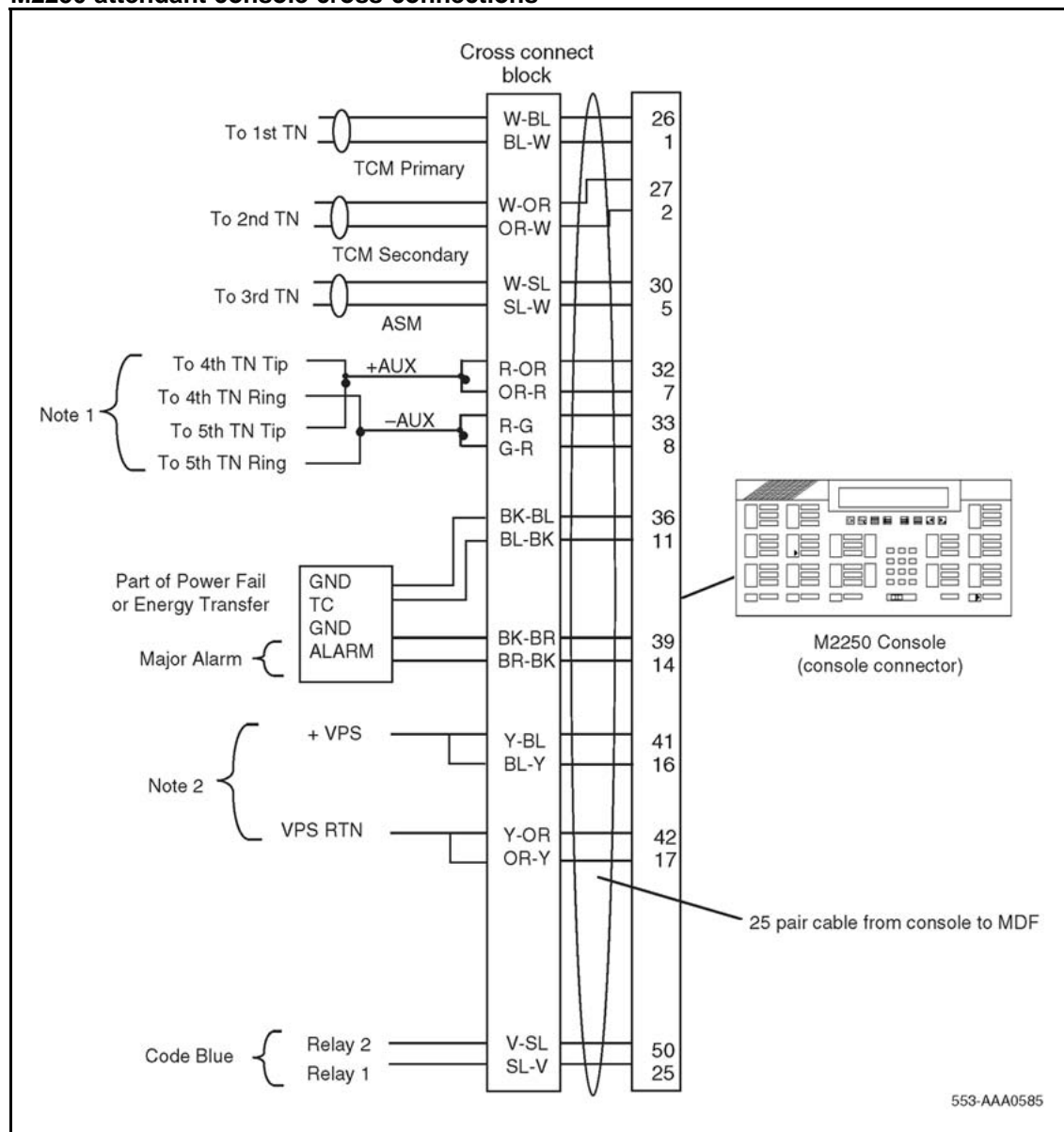

The following notes refer to [Figure 17 "M2250 attendant console cross-connections"](#) (page 53), which illustrates the M2250 attendant console cross-connections.

Note 1: The M2250 is powered by means of the line circuits. In addition to the primary TN, secondary TN, and ASM TN, two TNs are cabled to the M2250 using the +AUX and –AUX leads. The maximum loop length is 3000 ft of 24 AWG wire.

Note 2: When additional options are used (BLF or display backlight option), an additional 16 V DC power supply is required. The 16 V

DC source is cabled using +VPS and VPS RTN leads. The maximum distance from the console to the power source is 120 feet of 24 AWG wire. Please note: if both options are installed, only one 16 V DC power supply is required.

Note 3: Nortel recommends that five consecutive TNs on the line circuit be allocated for each console.

Note 4: When used with the ISDL, the M2250 requires NT8D02 or later.

Note 5: The third TN must be cross-connected to the console cable WH/SL pair whether or not an ASM (Attendant Supervisory Module) is installed. This third TN provides additional console power which is required.

Table 9 "M2250 attendant console connections" (page 54) on Table 9 "M2250 attendant console connections" (page 54) explains where each M2250 cable pair is connected. Table 10 "M2250 typical cross-connections" (page 56) on Table 10 "M2250 typical cross-connections" (page 56) lists the M2250 typical cross-connections.

Table 9
M2250 attendant console connections

Mounting cord	16/25-pair connector cable			
Lead designation	Pin number	Pair number	Color	Connected to
TCM primary	26	1T	W-BL	TN #1
	1	R	BL-W	
TCM secondary	27	2T	W-O	TN #2
	2	R	O-W	
Attendant Supervisory Module	30	5T	W-SL	TN #3
	5	R	SL-W	
Spare	31	6T	R-BL	
	6	R	BL-R	
+AUX	32	7T	R-O	TN #4
	7	R	O-R	
Note 1: Connect to Pin 3 or 28 of the appropriate PFJ5 terminal block.				
Note 2: Connect TC to Pin 29 or 5 and ALM to Pin 4 or 31 of the appropriate PFJ5 terminal block.				

Table 9
M2250 attendant console connections (cont'd.)

Mounting cord	16/25-pair connector cable			
Lead designation	Pin number	Pair number	Color	Connected to
-AUX	33	8T	R-G	TN #5
	8	R	G-R	
Spare	34	9T	R-BR	
	9	R	BR-R	
Spare	35	10T	R-SL	
	10	R	SL-R	
Power Fail or Energy Transfer	36	11T	BK-BL	GND (Note 1)
	11	R	BL-BK	TC (Note 2)
Spare	37	12T	BK-O	
Spare	12	R	O-BK	
Spare	38	13T	BK-G	
Spare	13	R	G-BK	
GND	39	14T	BK-BR	GND (Note 1)
Major Alarm	14	R	BR-BK	ALM (Note 2)
Spare	40	15T	BK-SL	
	15	R	SL-BK	
VPS	41	16T	Y-BL	
	16	R	BL-Y	
VPS RTN	42	17T	Y-O	
	17	R	O-Y	
<p>Note 1: Connect to Pin 3 or 28 of the appropriate PFJ5 terminal block.</p> <p>Note 2: Connect TC to Pin 29 or 5 and ALM to Pin 4 or 31 of the appropriate PFJ5 terminal block.</p>				

Table 9
M2250 attendant console connections (cont'd.)

Mounting cord	16/25-pair connector cable			
Lead designation	Pin number	Pair number	Color	Connected to
Spare				
Code Blue	50	25T	Y-SL	Relay 2
	25	R	SL-Y	Relay 1
<p>Note 1: Connect to Pin 3 or 28 of the appropriate PFJ5 terminal block.</p> <p>Note 2: Connect TC to Pin 29 or 5 and ALM to Pin 4 or 31 of the appropriate PFJ5 terminal block.</p>				

Table 10
M2250 typical cross-connections

Pair	Pins	Pair Color	DLC Connections	ISDLC Connections
1T	26	W-BL	Unit	Unit
1R	1	BL-W	0	0
2T	27	W-O	Unit	Unit
2R	2	O-W	1	8
3T	28	W-G	Unit	Unit
3R	3	G-W	2	1
4T	29	W-BR	Unit	Unit
4R	4	BR-W	3	9
5T	30	W-S	Unit	Unit
5R	5	S-W	4	2
6T	31	R-BL	Unit	Unit
6R	6	BL-R	5	10
7T	32	R-O	Unit	Unit
7R	7	O-R	6	3
8T	33	R-G	Unit	Unit
8R	8	G-R	7	11

Table 10
M2250 typical cross-connections (cont'd.)

Pair	Pins	Pair Color	DLC Connections	ISDLC Connections
9T	34	R-BR	Unit	Unit
9R	9	BR-R	8	4
10T	35	R-S	Unit	Unit
10R	10	S-R	9	12
11T	36	BK-BL	Unit	Unit
11R	11	BL-BK	10	5
12T	37	BK-O	Unit	Unit
12R	12	O-BK	11	13
13T	38	BK-G	Unit	Unit
13R	13	G-BK	12	6
14T	39	BK-BR	Unit	Unit
14R	14	BR-BK	13	14
15T	40	BK-S	Unit	Unit
15R	15	S-BK	14	7
16T	41	Y-BL	Unit	Unit
16R	16	BL-Y	15	15

Operation

This section contains operating procedures for the M2250 attendant console. The attendant console faceplate layout is shown in [Figure 14 "M2250 key designations in Shift mode \(QMT2 not enabled\)"](#) (page 49) through [Figure 16 "M2250 designations in Unshift mode \(QMT2 not enabled\)"](#) (page 51), starting on [Figure 14 "M2250 key designations in Shift mode \(QMT2 not enabled\)"](#) (page 49). Refer to these figures as the basis for component location references throughout this section.

M2250 configurations

The M2250 attendant console can be configured to operate with the QMT2 feature, which is provided by a QMT2 add-on module incorporated in the console. Instead of having to add a keystrip unit, the technician can set a

dip switch on the keyboard/controller Printed Circuit Panel (PCP) to ON (enable QMT2) or OFF (disable QMT2). It is important that the system software configuration and the QMT2 dip switch be set correctly.

For more information, refer to the section on LD15 in the following documents:

- *Features and Services Fundamentals-Six Books (NN43001-106_B1-B6) ()*
- *Software Input Output Administration (NN43001-611) ()*

QMT2 feature disabled

When the QMT2 feature is disabled, the following conditions apply:

- If the console is not in Shift mode, keystrip AK is inactive.
- If the console is in Shift mode, the keys in strip AK function as Trunk Group Busy (TGB) keys, if configured in the system software.
- If the operator presses any of these keys, the associated trunk group is busied out.
- The triangle points aimed to the left of keystrip AK are never active.
- If the operator presses any key outside keystrip AK when the console is in Shift mode, the console performs the function associated with that key. The Shift indicator remains on.
- The keys in keystrip BK function as Incoming Call Identification (ICI) keys.

QMT2 feature enabled

When the QMT2 feature is enabled, the following conditions apply:

- If the console is not in Shift mode, the keys in strip AK and/or BK function as Incoming Call Identification (ICI) keys.
- If the console is in Shift mode, the keys in keystrips AK and BK function as Trunk Group Busy (TGB) keys. That is, they imitate the keystrips of the QMT2 add-on module as follows:
 - The LCD indicators pointing to the left indicate busy trunks.
 - The LCD indicators pointing to the right indicate incoming calls.

Attendant PC requirements

To install the PC-based Console software application, a PC-compatible Pentium system is required, with the following:

- minimum 16 MB RAM
- hard disk with at least 10 MB free disk space
- 17-inch SVGA color monitor
- 16 bit sound board
- Network interface adapter
- RS232 serial port

For complete installation and operation instructions, refer to the *Attendant PC Console Fundamentals (NN43001-520)* ().

Figure 18
PC Console Interface Unit

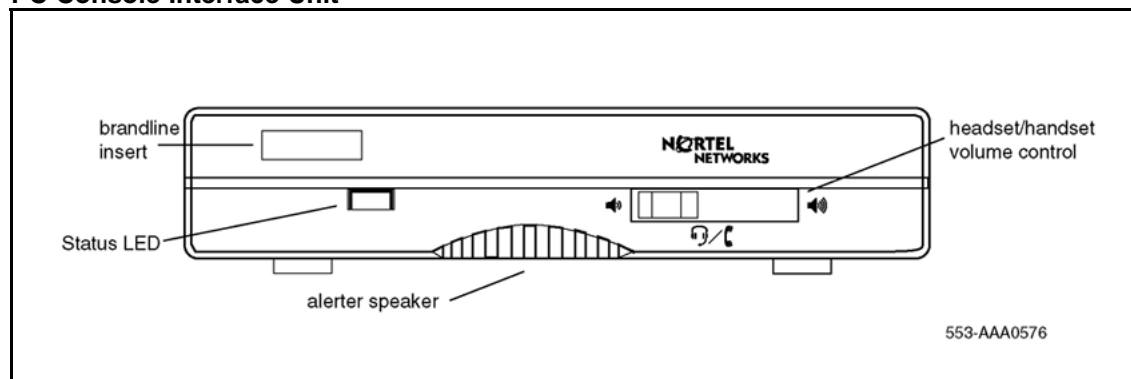

M2250 feature key modes

Functions shown for some of the feature keys in [Table 4 "Softkey definitions and functions" \(page 36\)](#) [Table 4 "Softkey definitions and functions" \(page 36\)](#) vary depending on which console mode is in effect while the key is being pressed. [Table 11 "Softkey alternate functions" \(page 60\)](#) on [Table 11 "Softkey alternate functions" \(page 60\)](#) lists the various alternate feature key functions.

When a feature key is pressed while the attendant console is in a mode other than normal or Level 1, nothing happens.

When in the normal call processing mode, access the Level 1 mode by pressing the **Shift** key. The LCD indicator beside the shift key lights and remains on throughout all options and menus. It goes out only upon return to normal call processing. All call processing keys that do not have a dual function perform normally while the console is in Level 1 mode. Press the **Shift** key again to return to normal call processing.

On the M2250 attendant console, press the pound (#) key to exit from any submenu from the Options menu, or from the Diagnostics menu to normal operating mode. Press the Shift key to return to the Level 1 mode.

Level 1 mode also provides access to additional call processing features, as well as to options and maintenance features. One of the additional call processing features is access to Trunk Group Busy (TGB) keys that are locked out in normal mode. For example, in normal mode, there are ten available TGB keys on the M2250. With QMT2 enabled, the number of TGB keys on each console is doubled.

Table 11
Softkey alternate functions

Key	Operational mode	Function
F1	Normal	Selects line 2 of the display for scrolling.
F2	Normal	Scrolls left on the selected line, at 8 characters per step.
F3	Normal	Scrolls right on the selected line, at 8 characters per step.
F4	Normal	Selects line 3 of the display screen for scrolling.
Shift, F1	Level 1	Selects the Options menu.
Shift, F2	Level 1	Turns down the alerter speaker volume.
Shift, F3	Level 1	Turns up the alerter speaker volume.
Shift, F4	Level 1	Selects the Diagnostic menu. (A password must be entered on the M2250 before the Diagnostics menu appears.)
Example:		
Press Shift and F1 (in sequence)	Options menu	The Options menu is displayed.
	Press dial pad key 1	Accesses Contrast menu. (Refer to user guide for contrast setting routines.)
	Press dial pad key #	Returns to Options menu.

M2250 console diagnostics

Use the Diagnostics menu to check the functions of the console and to perform tests. To enter the Diagnostics mode, use [Procedure 13 "Entering the M2250 Diagnostics mode"](#) (page 61). [Figure 19 "Console Diagnostics menus"](#) (page 61) shows the main Diagnostics menu for the M2250 attendant console.

Procedure 13 Entering the M2250 Diagnostics mode

Step	Action
1	Press the Shift key.
2	Press the key (F4 function key).
	
3	On M2250 consoles, enter the password 9999.
4	Press the asterisk (*) key to enter Diagnostics menu 1. To toggle between menu 1 and menu 2, press the asterisk (*) key.
5	To quit the Diagnostics mode, press the octothorpe (#) key.
--End--	

Follow the procedures listed below to perform the Diagnostic tests.

Figure 19
Console Diagnostics menus

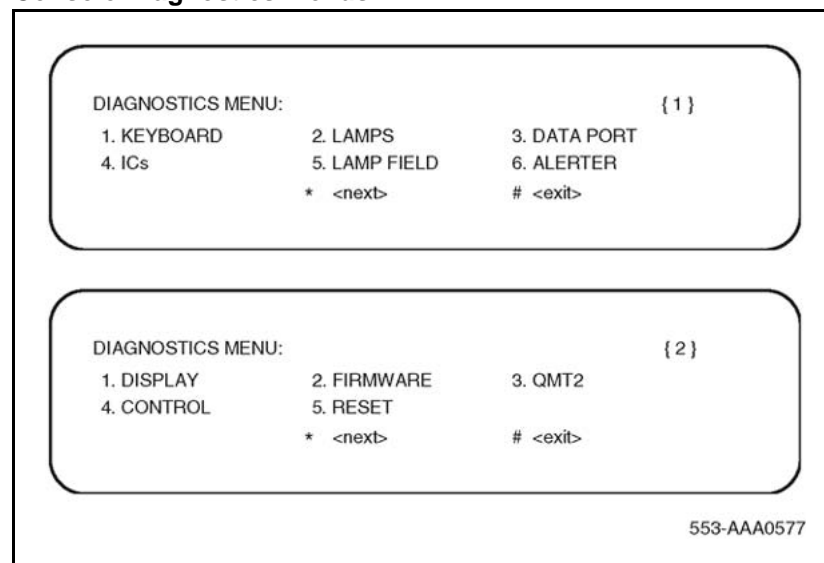

Procedure 14 Testing the Keyboard

Step	Action
------	--------

Use this procedure to check the functionality of each key on the console. When a key is pressed, its location code is displayed within parentheses. For example, (00) denotes the upper left-hand ICI key.

- 1 From Diagnostics menu 1, press 1.
- 2 Press any key on the console. The display shows the key's location code, indicating that the key is functional. [Table 12 "Key location codes for console diagnostics" \(page 62\)](#) shows the key location codes.
- 3 Press the octothorpe (#) key to exit and return to Diagnostics menu 1.

--End--

Table 12
Key location codes for console diagnostics

		22	21	20	34		54	60	61	62		
00	10								70		80	90
01	11								71		81	91
02	12								72		82	92
03	13	23						63	73		83	93
04	14	24						64	74		84	94
05	15	25		35	45	55		65	75		85	95
06	16	26		36	46	56		66	76		86	96
07	17	27		37	47	57		67	77		87	97
08	18	28		38	48	58		68	78		88	98
09	19	29						69	79		89	99

Procedure 15 Testing the LCD indicators

Step	Action
------	--------

Use this procedure to check the functionality of each LCD indicator on the console.

- 1 From the Diagnostics menu 1, press 2.
- 2 Press 1 to turn all lamps ON. Press the asterisk (*) to turn each lamp OFF one by one.

-
- 3 Press 2 to turn all lamps OFF. Press the asterisk (*) to turn each lamp ON one by one.
 - 4 Press the octothorpe (#) to exit and return to Diagnostics menu 1.

--End--

Procedure 16
Testing the data port

Step	Action
-------------	---------------

Use this procedure to perform a loopback test on the RS-232 port at the back of the console. Before performing the test, a connector (25-way D-plug) with pin 2 shorted to pin 3 should be inserted in RS-232 port. A failure code is displayed if any error is found.

- 1 From Diagnostics menu 1, press 3. The display shows OK if the test is successful.
- 2 Press the asterisk (*) to repeat the loopback test.
- 3 Press the octothorpe (#) to exit and return to Diagnostics menu 1.

--End--

Procedure 17
Testing the ICS

Step	Action
-------------	---------------

Use this procedure to check the functionality of any peripheral devices connected to the User Interface Printed (UIP) and the Audio System Interface Printed (ASIP) microprocessor circuit cards within the console. A failure code is displayed if any error is found.

- 1 From Diagnostics menu 1, press 4.
- 2 Press the asterisk (*) to perform the ICS test.
- 3 Press the octothorpe (#) to exit and return to Diagnostics menu 1.

--End--

Procedure 18
Testing the Busy Lamp Field/Console
Graphics Module

Step	Action
-------------	---------------

Use this procedure to check the functionality of the BLF/CGM. Once in this menu, the dial pad is in CGM mode. When any dial pad keys are pressed, except the octothorpe (#) key, the keys are echoed on the BLF/CGM.

- 1** From Diagnostics menu 1, press **5**.
- 2** Press keys from **0 – 9** and the asterisk (*) on the dial pad. Check the CGM to see that they are echoed.
- 3** Press the octothorpe (#) to exit and return to Diagnostics menu 1.

Note: For more information on installation and operation of this feature, see [“Busy Lamp Field/Console Graphics Module” \(page 19\)](#), or refer to the *Busy Lamp Field/Console Graphics Module User Guide* () .

--End--

Procedure 19
Checking the Alerter

Step	Action
-------------	---------------

Use this procedure to check the pitches and volume levels of the alerter and auxiliary tone channel.

- 1** From Diagnostics menu 1, press **6**.
- 2** Follow these instructions in any order:
Press key **1** to turn the buzz and auxiliary tones ON.
Press key **2** to turn the buzz and auxiliary tones OFF.
Press key **3** to increase the pitch of the buzz and auxiliary tones.
Press key **4** to decrease the pitch of the buzz and auxiliary tones.
Press key **5** to increase the volume of the buzz and auxiliary tones.
Press key **6** to decrease the volume of the buzz and auxiliary tones.
- 3** Press the octothorpe (#) to exit and return to Diagnostics menu 1.

--End--

Procedure 20
Testing the Display

Step	Action
------	--------

Use this procedure to check the functionality of the alphanumeric display panel. Cycle through a number of different display patterns to check for visual defects.

- | | |
|---|---------------------------------------------------------------------------------------------------------------------------------------------|
| 1 | From Diagnostics menu 2, press 1 . |
| 2 | Press the asterisk (*) to change the display screen pattern. Continue changing the pattern until all the patterns have been cycled through. |
| 3 | Press the octothorpe (#) to exit and return to Diagnostics menu 1. |
-

--End--

Procedure 21
Displaying the firmware version numbers

Step	Action
------	--------

Use this procedure to display the release and issue numbers of the firmware installed on the UIP and ASIP microprocessor circuit cards.

- | | |
|---|------------------------------------------------------------------------------------------------------------------------------------------------------------------------------------------|
| 1 | From Diagnostics menu 2, press 2 . The display shows the firmware release and issue numbers, as shown below:

DIAGNOSTICS: FIRMWARE
ASIP: XX XX
UIP: XX XX |
| 2 | Press the octothorpe (#) to exit and return to Diagnostics menu 1. |
-

--End--

Procedure 22
Displaying and resetting the QMT2 switch status

Step	Action
------	--------

Use this procedure to display the current state of the QMT2 dip switch inside the console and to change the setting for verification testing (LD 31). After a change, the actual switch setting will return to its original state after a time-out period of about three minutes.

- | | |
|---|-----------------------------------------------------------|
| 1 | From Diagnostics menu 2, press 3 . |
| 2 | Press the asterisk (*) to toggle between QMT2 ON and OFF. |
-

- 3 Press the octothorpe (#) to exit and return to Diagnostics menu 1.

--End--

Procedure 23
Toggleing control gates

Step	Action
------	--------

Use this procedure to turn the conference bridge analog control gates, the auxiliary tone channel, and the Code Blue Relay ON or OFF. Note that the auxiliary control only affects the control gate on the ASIP circuit card. To actually generate a tone, use the Alerter menu.

- 1 From Diagnostics menu 2, press "4."

DIAGNOSTICS: CONTROL

1. SCR 2. DST 3. ARX 4. ATX 5. TON 6. REL

{ 0 } { 0 } { 0 } { 0 } { 0 } { 0 }

* <OFF>

<exit>

- 2 Follow the appropriate instruction below:
- Press key **1** to toggle the primary control gate between ON and OFF.
- Press key **2** to toggle the secondary control gate between ON and OFF.
- Press key **3** to toggle the attendant receive control between ON and OFF.
- Press key **4** to toggle the attendant transmit control between ON and OFF.
- Press key **5** to toggle the auxiliary tone control between ON and OFF.
- Press key **6** to toggle the relay control between ON and OFF.
- 3 Press the asterisk (*) to turn all the control gates OFF.
- 4 Press the octothorpe (#) to exit and return to Diagnostics menu 1.

--End--

Reset

To perform a hard reset of the console, from Diagnostics menu 2, press **5**. The reset is performed immediately. All devices and memory on the UIP and ASIP boards are reset as if the power cord were unplugged and plugged in again.

M2250 failure codes

A failure code appears on the display in response to the detection of a hardware fault.

Refer to [Table 13 "M2250 failure codes" \(page 67\)](#) for an explanation of failure codes and possible solutions.

Table 13
M2250 failure codes

Failure code	Printed circuit pack (PCP)	Reason	What to do
40H	UIP	The PSG, U13, is not responding.	Unplug the line cord and plug it in again. If the failure code still appears, there is an electrical fault in the console, and it should be returned.
			Note: Log the failure code with the returned unit, as it gives an indication of which component has failed.
20H	UIP	The RTC, U16, is faulty.	Same as for 40H.
10H	UIP	The RAM IC, U1, is faulty.	Same as for 40H.
08H	UIP	A key in column A is stuck.	Unplug the line cord. Free the key if it is stuck. Plug in the line cord. If the failure code still appears, the console is faulty and should be returned.
09H	UIP	A key in column B is stuck.	Same as for 08H.
0AH	UIP	A key in column C is stuck.	Same as for 08H.
0BH	UIP	A key in column D0 is stuck.	Same as for 08H.
0CH	UIP	A key in column D1 is stuck.	Same as for 08H.
0DH	UIP	A key in column D2 is stuck.	Same as for 08H.
0EH	UIP	A key in column E is stuck.	Same as for 08H.
0FH	UIP	A key in column F is stuck.	Same as for 08H.

Table 13
M2250 failure codes (cont'd.)

Failure code	Printed circuit pack (PCP)	Reason	What to do
A0H	ASIP	The RS-232 has failed the loopback test.	Check to see if the loopback connector is inserted. If not, insert it and perform the loopback test again. If the failure code still appears, turn the console off and on while the connector is inserted. Perform the loopback test again. If the failure code still appears, the console is faulty and should be returned.
90H	ASIP	ASM A44#3, U1, is faulty.	Same as for 40H.
88H	ASIP	Secondary A44#2, U2, is faulty.	Same as for 40H.
84H	ASIP	Primary A44#1, U1, is faulty.	Same as for 40H.
82H	ASIP	The UART, U5, is faulty.	Same as for 40H.
81H	ASIP	The RAM, U8, is faulty.	Same as for 40H.

The failure codes produced by the firmware in response to the detection of a hardware fault are bit-significant as follows:

B7	B6	B5	B4	B3	B2	B1	B0
0	PSG	RTC	RAM	KEYS	c2*	c1*	c0*
1	ASIP	RS-232	A44#3	A44#2	A44#1	UART	RAM
<p>* Refers to key's column number.</p> <p>Note: Bit 7 indicates whether the failure occurred on the user interface printed circuit card (UIP) (B7=0) or on the audio and system interface printed circuit card (ASIP) (B7=1).</p>							

In most instances, the failure code accurately identifies the faulty hardware component. However, if the microprocessor is faulty, the readings may be unreliable or misleading.

Failure code A0H is always shown if the loopback test has not been performed. Refer to [Procedure 16 "Testing the data port"](#) (page 63).

M2250 feature operation

Time and date

On the M2250, the time and date are automatically downloaded from the system on power-up or console reset. The time and date are downloaded by the switch whenever it runs a lamp audit. Only the visual format can be changed.

Trunk Group Busy indicators

Trunk Group Busy (TGB) indicators show the status of each group of trunks. If a TGB indicator is on steadily, the attendant has busied out all trunks in that group by pressing the Shift key plus the TGB key. If a TGB indicator is flashing, all the trunks in that group are actually busy.

In Supervisory mode, TGB indicators show the status of other consoles in the customer group. If the indicator is off, the attendant position is in a Position Busy mode. When an indicator associated with a particular attendant is on, the attendant is available to service calls.

Note: The M2250 attendant console must be equipped with the Attendant Supervisory Module (NT7G10AA) to allow attendant supervision.

Incoming Call Indicators

Incoming Call Indicators (ICI) display the various types of incoming calls presented to the attendant console. They also indicate the number of calls and the length of time calls have been queued.

- If the indicator is on, one call has been queued for less than a certain length of time (as defined by software).
- If the indicator is flashing, one call has been queued for more than the defined length of time, or there is more than one call in the queue.

Night service/busy

When the **Shift** key is off, press the **Busy** key to put the attendant console into Position Busy mode. When the **Shift** key is on, press the **Busy** key to put the console into Night Service mode. To return to normal operating mode, press the **Busy** key again.

In a multi-console system, activating Night Service mode will busy out all attendant consoles in the system.

Enhanced Night Service

This feature allows Public Network (Central Office [CO], Direct Inward Dial [DID], Foreign Exchange [FEX], and Wide Area Telephone service [WAT]) trunks to be assigned to specific Directory Numbers (DN) during Night Service.

With this feature each customer will be able to assign Public Network trunks to one of nine Night Groups. Each Night Group will allow the customer to define up to nine Night DNs. During Night Service incoming calls will be routed to one of the Night DNs defined for the group. The actual DN the call will be routed to is determined by the Night Service Option number selected at that time.

The customer will also be able to define whether Night Call Waiting tone will be given to Night stations. With Night Call Waiting tone allowed, busy Night stations are notified when an incoming call is terminating on them. The incoming call will be queued on the Night station until it becomes idle. When the Night station becomes idle, the incoming call will be presented.

This enhancement allows incoming DID trunks to be queued against busy Night stations, thereby making the operation of the DID trunks the same as for all other Public Network trunks.

Attendant Blocking of DN

The Attendant Blocking of DN (ABDN) feature enables the attendant to block a DN for a telephone from receiving or making calls. This is particularly useful when a caller dials the attendant DN and requests an external (long distance) call. If the caller chooses to disconnect until the attendant successfully places the call, the requesting DN becomes idle and can receive or make calls. Therefore, the requesting DN could be busy when the attendant establishes the requested call.

To prevent the requesting DN from being busy when the requested call is completed, the attendant can block the DN from making or receiving calls. To callers attempting to contact the blocked DN, the line appears busy. To a caller attempting to use the blocked DN, the line is connected to the attendant.

When the attendant completes the external call, the attendant can call the blocked DN and extend the call. This feature applies to both stand-alone and ISDN network environments.

The Attendant Blocking of DN feature is available on the M2250 attendant consoles. It is not valid on M2616 telephones used as attendant consoles.

Attendant and Network Wide Remote Call Forward

This modification to the Remote Call Forward feature (RCFW) allows a user to program a call forward Directory Number from any attendant console or station throughout the network. An RFW key on the attendant console allows an attendant to view any station's call forward status and to activate or deactivate call forward for a station.

Refer to *ISDN Primary Rate Interface Fundamentals (NN43001-569)* () for further details.

Network Attendant Services

This feature allows attendant services to be distributed anywhere within a Meridian ISDN network. If, at the time of an attendant request, attendant services are not available at a station's local node, connection to an attendant at a remote node takes place. Call treatment is the same as for a connection to a local attendant node.

Call processing

The attendant answers an incoming call by pressing the flashing loop key.

To answer a specific type of incoming call, press the ICI key next to the appropriate ICI indicator. This removes the call from the queue and presents it to the attendant.

ICI key assignments

An ICI key may be assigned more than one call type. Refer to *Software Input Output Administration (NN43001-611)* (). If the Attendant Call Party Name Display (ACPND) feature is equipped, all incoming calls are displayed by calling party name or external call source. The following examples list possible ICI key assignments:

- **Attendant Intercept** indicates that a call is being made by a station to a facility to which that station is restricted, and the call has been routed to the attendant console.
- **Listed Directory Numbers (maximum four)** indicates that a call is being made to an attendant console associated with one of the listed directory numbers.
- **Dial 0** indicates that a station that is not fully restricted has dialed 0.
- Fully Restricted Station indicates that a fully restricted station has dialed 0.
- **Foreign Exchange** indicates that the incoming call is from a foreign exchange.
- Wide Area Telephone Service indicates that the incoming call originated at a wide area telephone exchange.
- **Recall** indicates that a camped-on call or a call extended to an idle station has not been answered for 30 seconds or that a station is recalling the attendant.
- **Call Forward** indicates that the call is being forwarded to the console from a station within the system.
- **Tie Trunk** indicates that the incoming call is on a tie trunk.

Operating keys

The operating key/lamp strips CI/CK, DI, EI, and FI/FK allow the attendant to process calls from the console.

Key/lamp strips CI/CK and FI/FK have permanently assigned functions as given in the following list.

- **Release** allows the attendant to release a call presented to the console. When the LCD associated with the RLS key is lit, it indicates that no incoming calls are being presented to the console.
- **Loop Keys/Lamps** allow the attendant to answer and originate calls from the console. The first call in the incoming queue is automatically presented to an idle loop key. Subsequent calls are queued and presented to a loop key when a loop becomes idle. Call selection is made by pressing the required ICI key. This action causes the call, which was automatically presented to the loop key by the system, to be replaced by the selected incoming call. In all cases, when the loop key is pressed, all ICIs go dark except the one associated with the call presented to the loop key.
- **Position Busy** enables the attendant to put the console in Position Busy mode. All calls directed to a console in Position Busy mode are redirected to a free console in multiconsole installations or to the night connection in single console installations. When a console is in Position Busy mode, "BUSY" is shown on line 4 of the display.
- **Night Service** permits incoming calls to the attendant to be routed to a preselected station. The Night Service key enables the attendant to assign the Night Directory Number (DN) and to initiate Night Service. When assigning the Night Service DN, "NIGHT" flashes on line 4 of the display. When Night Service is on, "NIGHT" appears without flashing on the display.
- In a multiconsole system, activating Night Service will busy out all attendant consoles in the system.
- **Hold** allows the attendant to hold an active call at the console while serving other calls.
- **Conference** permits the attendant to set up a conference of up to five conferees plus the attendant.
- **Release Destination** allows the attendant to release the called party from a call held at the console while holding the calling party.
- **Release Source** allows the attendant to release the calling party from a call held at the console while holding the called party.
- **Signal Source and Destination** allows the operator to recall either party to a call held on the console.

- **Exclude Destination** excludes the called party from an established call held at the console, allowing the attendant to speak privately with the calling party.
- **Exclude Source** excludes the calling party from an established call held at the console, allowing the attendant to speak privately with the called party.

Feature keys

Any of the keys on keystrip FK can be assigned any of the optional features in the list that follows except the Barge-In and Busy Verify features. These require five LCD indicator states (off, on, and flash at 30, 60, or 120 impulses per minute). If Barge-In or Busy Verify is required, it must be assigned to keys FK-0 and FK-1.

All other features may be assigned to any of the keys on strip FK. Refer to *Software Input Output Administration (NN43001-611)* () for additional information. The following are some of the more common feature keys:

- **Attendant End to End Signaling** enables the attendant to send dual tone multifrequency (DTMF) signals to either the source or destination party.
- **Busy Verify** allows the attendant to confirm that a station returning a busy signal is actually being used.
- **Barge-In** allows the attendant to enter an established trunk connection for the purpose of talking to one or both parties.
- **Paging** allows access to a public address facility.
- **Speed Call** allows numbers to be dialed automatically by pressing the SPEED CALL key and dialing a 1- or 2-digit code.

Call Waiting indicator

The Call Waiting indicator indicates that there is a queue of calls to be answered. When one or more calls are waiting, "CW" appears on line 4 of the display. The CW display changes from steady to flashing when waiting calls exceed a certain number or when a call has been waiting longer than a specified time.

The maximum number of waiting calls and the maximum hold time for each waiting call to be answered can be set with a data administration task. Refer to *Features and Services Fundamentals-Six Books (NN43001-106_B1-B6)* () for more information.

An optional buzz is available to indicate when the first call enters the queue. The number of waiting calls can be viewed on the LCD screen by pressing a key assigned on the attendant console. On the M2250, the number of waiting calls can be displayed continuously on line 4 of the display, if defined in LD15 and selected from the Options menu.

Alarm indicators

Alarms appear on line 4 of the display. "MN" indicates a minor alarm condition; "MJ" indicates a major alarm. A minor alarm is an indication of a minor system failure affecting a limited number of lines or trunks. A major alarm indicates that Emergency Transfer may have been initiated. See "Emergency Transfer" (page 74).

Emergency Transfer

If a major equipment or power failure halts local call processing, preselected CO trunks are automatically connected to preselected stations (predetermined and hard-wired at installation time) through relays in the system. Emergency Transfer can also be activated manually by a switch underneath the attendant console.

If the switch is activated while the console has power, the word "EMERGENCY" appears on line 4 of the display.

Attendant Administration

Attendant Administration is an optional feature that allows the attendant to modify some of the features assigned to selected telephone sets within the attendant's customer group. The attendant can enter a special program mode with an assigned key.

Once in the program mode, the console key/lamp strips have different functions from those during normal call processing. A plastic overlay can be placed over the console keyboard to identify the altered key functions. Refer to *Features and Services Fundamentals-Six Books (NN43001-106_B1-B6)* () for Attendant Administration description and operating procedures.

Collect Call Blocking

The Collect Call Blocking feature enables a system administrator to block long distance collect call service calls on incoming Direct Inward Dialing (DID) and Public Exchange/Central Office trunks (analog or DT12).

Under the following conditions, the system sends a special answer signal to the Central Office to indicate that collect calls cannot be accepted:

- The Collect Call Blocking (CCB) package 290 is enabled.
- The incoming route has CCB enabled via the CCB prompt in the Route Data Block.
- The call is answered by a CCB user (that is, Collect Call Blocking Allowed Class of Service or option).

Classes of service and prompts are provided which enable administrators to inhibit specific users from receiving collect DID and Central Office calls. These can be configured for the following:

- PBX and BCS through the Collect Call Blocking Allowed/Denied (CCBA/CCBD) option
- Attendant and Network Alternate Route Selection calls on a per customer basis through CCBA/CCBD option
- Automatic Call Distribution (ACD) queues through the CCBA prompt
- Direct Inward System Access (DISA) through the CCBA prompt
- Tandem calls dialed with Coordinated Dialing Plan (CDP) (Trunk Steering Code, Distant Steering Code) through the CCBA prompt
- Tandem non-CDP calls through the CCBA prompt in the Route Data Block from the outgoing trunk route

When a call is answered by a CCB user, the system sends the CCB answer signal in place of the regular signal for incoming DID/CO calls from the routes with CCB enabled. If the call is a collect call, The CO will disconnect the call.

Alarm Management

The Integrated Alarm Management feature is a series of subfeatures which improve the handling of key alarm messages generated by the system and its Application Processors.

It also clarifies existing alarm messages and makes attendant console alarm lamp signals more meaningful. The system has three levels of alarm: critical, major, and minor. The attendant console alarm lamp will light when critical alarms occur.

Digital Trunk Interface, CIS

The CIS DTI trunk feature provides connectivity between the system and digital trunks used in the Commonwealth of Independent States (CIS).

The CIS 2 Mbps DTI feature enables the system to connect digital DID/COT trunks to a CIS Local Central Office and to a CIS Toll Exchange (through Local CO and Public Network, or directly for incoming toll call connections).

This link supports DID/COT trunking types, and requires that the system be equipped with at least one CDT12/CSDT12 digital trunks pack, as well as associated software.

DPNSS Executive Intrusion

Executive Intrusion (EI) allows an originating party to break into an established call between two other parties (the wanted and the unwanted parties) under certain circumstances. If intrusion succeeds, a conference takes place on the wanted node between the originating, wanted and unwanted parties.

EI succeeds in breaking into the call based on comparisons between the Intrusion Capability Level (ICL) of the originating party and the Intrusion Protection levels (IPL) of the wanted and unwanted parties.

The system provides Executive Intrusion from attendant consoles. Executive Intrusion from Telephone Sets is not supported. However, a Meridian 1, CS 1000M, or CS 1000S PBX will accept an EI activation request from an ordinary set on a third party PBX.

Attendant Monitor

Attendant Monitor is a customer-defined option which allows the attendant to monitor – in listen only mode – any established call involving a set or trunk on the customer with or without the connected parties being aware that monitoring is taking place (depending on the configuration of the customer tone option).

The differences between the existing Busy Verify and Barge-in features and the Attendant Monitor feature are the following:

- Attendant Monitor provides a listen only path for the attendant.
- There is no click sound given to the connected parties upon Attendant connection when the no tone option is configured.
- The tone to the connected parties may or may not be given depending on the customer tone options for Attendant Monitor.
- The display (if there is one) on any of the parties involved in the calls does not indicate that the Attendant is monitoring.

Busy Verify and Barge-in Enhancement

Attendant Monitor changes the operation of Busy Verify and Barge-in slightly. Tone is now configurable. Busy Verify and Barge-in restrictions relating to the Warning Tone Allowed/Denied Class of Service apply to Attendant Monitor as well.

Attendant Forward No Answer

Attendant Forward No Answer allows two enhancements to existing operations. The first enhancement permits calls presented to the attendant to forward to a second attendant or the night DN when a customer-defined time expires. The second enhancement allows DID or CO calls to any set during night service to disconnect if not answered within a predefined number of ring cycles.

Attendant Forward No Answer is selectable on a customer basis, and is included in the package 134, AFNA.

Semi-Automatic Camp-On

Semi-Automatic Camp-On is an option to the current camp-on operation. When the party to which a call is camped-on becomes free, the attendant is recalled first instead of the wanted party being rung immediately. The modification is implemented under the Semi-Automatic Camp-on (SACP) package.

When an external call is camped on to a busy DN by an attendant or a set, the called party receives a buzz (for digital sets) or a burst of tone (for analog [500/2500-type] sets), indicating camp-on. Without SACP, if the called party becomes idle within a customer-defined time, the camped-on call rings the station immediately.

With SACP, if the called party becomes idle, the camped-on call recalls the attendant instead of ringing the called party. The called party meanwhile is kept busy from receiving any calls (but is still able to originate calls).

A programmable key, the Semi-Automatic Camp-on Recall (SACP) key is included with the SACP feature. When a recall is presented to the console, the RECALL ICI lamp and the SACP lamp light up. After answering the recall from the calling party, the attendant can ring the called party by pressing the SACP key. The attendant can then hold the call on the console, or release the call as usual.

When the attendant tries to present the call (after it has recalled to the attendant) to the wanted party, this party may have originated another call. In that case, the attendant receives the indication that the set is busy, and can then camp-on the call again or release it, as usual. On a second camp-on, the attendant must activate the SACP feature again, if needed.

The SACP feature is active either for all camped-on calls or on a per-call basis depending on the customer option. When the per-call basis is chosen, the attendant activates the feature by pressing the SACP key before camping-on the call. If the SACP key is pressed twice, the associated lamp goes dark, and the SACP feature becomes inactive for the call.

Series Call

The Series Call feature causes a source call (either an attendant-answered incoming call, or an attendant-originated trunk call), that has been extended to an internal destination party, to be recalled to the attendant when the destination party hangs up. The attendant can then send the source call to another destination party. This feature enables a caller to talk to more than one party without having to disconnect and call again. Recall to Same Attendant must be allowed, otherwise the recall is routed to the first available attendant. This process can be repeated for as many destinations as requested by the caller.

A Series Call is canceled if one of the following occurs:

- the attendant presses the SECL key while the associated lamp is lit
- the attendant extends the source to a trunk while the SECL lamp is lit
- the attendant enters Night Service after extending the call and prior to receiving the recall
- the destination is call forwarded to a trunk
- the source disconnects

Powering and reset

After a power failure or a temporary corruption of data, the M2250 attendant console is reset automatically.

If a permanent fault condition is detected, the console enters the maintenance mode (Position Busy), and a failure message is displayed on the LCD screen.

Note 1: The failure code format is XXH, where XX is a two-digit hex-code indicating where the fault has been detected. Refer to [Table 13 "M2250 failure codes" \(page 67\)](#) for explanations of the failure codes.

Note 2: When the BLF/CGM is attached to the console, an additional 16 V DC power supply (A0367601) is required for optional backlighting.

M2016S Secure Set

Contents

This section contains information on the following topics:

- “Introduction” (page 79)
 - “Software requirements” (page 81)
- “Physical description” (page 81)
 - “LCD indicators” (page 81)
 - “Volume control” (page 81)
 - “Message Waiting lamp” (page 82)
- “Features” (page 82)
 - “Display Module” (page 83)
 - “Program key” (page 83)
 - “On-hook security” (page 83)
- “Specifications” (page 84)
 - “Environmental and safety considerations” (page 84)
 - “Line engineering” (page 84)
 - “Local alerting tones” (page 85)
 - “Power requirements” (page 85)
- “Installation” (page 87)
 - “Packing and unpacking” (page 87)
 - “Installation and removal of M2016S Secure Set” (page 88)
 - “Designate the telephone” (page 92)
 - “Cross-connect the telephone” (page 93)

Introduction

The M2016S is a Telephone Security Group Class II-approved telephone designed to provide on-hook security. It is a high-performance multi-line telephone with 16 programmable feature keys. The M2016S uses relay circuitry that physically disconnects the handset from the telephone circuit

when the switchhook is depressed. The red LED triangle lights steadily when the phone is not secure (that is, when the handset is off the hook, the phone is ringing, or the handset/piezo relays are connected). The red LED triangle blinks when a message is waiting.

The M2016S has no handsfree capability. The M2016S does not support any accessories, options, or add-on modules.

The telephone's dimensions are as follows:

Length: 9.75 in. (250 mm.)

Width: 9.45 in. (235 mm.)

Height: 3.64 in. (93 mm.)

Weight: approximately 2 lbs. (1 kg.)

Figure 20 "M2016S Secure Set" (page 80) illustrates the M2016 Secure Set.

Figure 20
M2016S Secure Set

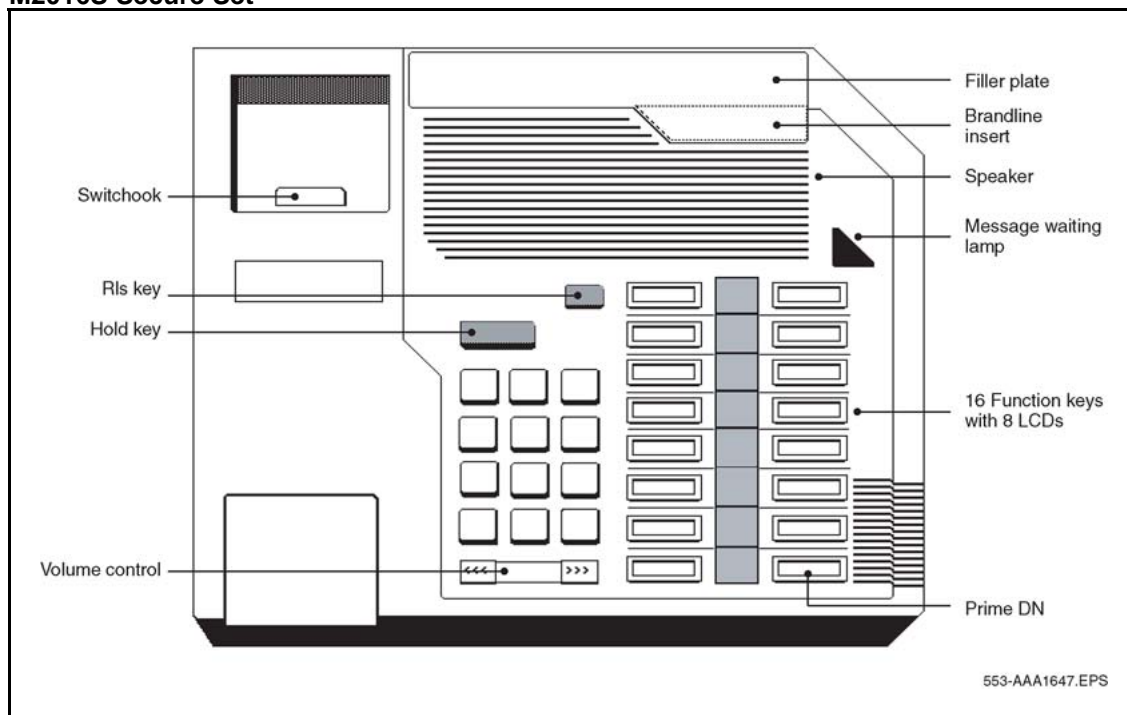

Software requirements

The option number for the M2016S is 170. The mnemonic is ARIE. The DSET package (88) and the TSET package (89) are required.

Physical description

The M2016S is equipped with:

- “LCD indicators” (page 81)
- “Volume control” (page 81)
- “Message Waiting lamp” (page 82)
- Hold key
- Release key
- Speaker

LCD indicators

The M2016S has a number of programmable keys with LCD indicators that can be assigned to any combination of directory numbers and features. The lower right-hand key (key 0) is reserved for the Primary DN.

When equipped with a Display module, key 07 is automatically assigned as the Program key and cannot be changed.

LCD indicators support 4 key/LCD states:

Function	LCD state
idle	off
active	on (steady)
ringing	flash (60 Hz)
hold	fast flash (120 Hz)

Note: An indicator fast flashes when a feature key is pressed but the procedure necessary to activate the feature has not been completed.

Volume control

One key with two toggle positions controls volume. Pressing the right "volume up" or left "volume down" side of the key incrementally increases or decreases the volume for the tone or sound which is currently active. The volume settings are retained for subsequent calls until new volume adjustments are made. If the telephone is equipped with a Display Module, volume can be adjusted at any time with the setting displayed on the screen (in Program mode).

Handset volumes can be configured to return to nominal on a per call basis.

You can adjust the volume of the following tones, while they are audible:

- ringing
- handset/headset
- buzz
- on-hook dialing

When the telephone is disconnected, all volume levels will return to default values upon reconnection.

Message Waiting lamp

The telephone has a red triangle in the upper right-hand corner that lights brightly to indicate a message is waiting. This LED is the primary message waiting indicator and lets you know a message is waiting regardless of whether the telephone has a message waiting key/lamp pair. You must have Message Waiting CCOS configured.

If you do assign a message waiting key/lamp pair, there will be two indications of a message waiting:

- the red Message Waiting triangle blinks, and
- the LCD associated with the Message Waiting key flashes.

You may assign an Autodial key that dials the message center (or voice mail system) to avoid the double indication, or have no key/lamp pair assigned to the message center.

The Message Waiting lamp is also used to indicate security of the M2016S. The red LED triangle lights steadily when the phone is not secure (handset is off-hook, phone is ringing or any time the handset/piezo relays are connected). The red LED triangle blinks when a message is waiting.

Features

The M2016S has 16 programmable keys. Earlier models can have a Display Module added. Later models of the set come with a display pre-installed.

Note: If the set is equipped with a Display, the number of programmable keys is reduced by one, as key 07 automatically becomes the Program key.

The features of the M2016S are as follows:

- “Display Module” (page 83) (field-installable)
- “Program key” (page 83)
- “On-hook security” (page 83)

For more information on M2016S features and operation, refer to *Nortel M2016S Secure Set User Guide* () or *Nortel M2016S Secure Set Quick Reference Guide* () .

Display Module

A 2-line by 24-character Display Module (NT2K28ABxx) provides system prompts, feedback on active features and valuable calling party information. In addition, you can modify various set features such as volume and screen contrast using the Program key (top right function key). You can enable a Call Timer which times calls made or received on the prime DN.

The Display Module supports normal business features in several languages, including English, Spanish, and Quebec French.

Note: You can adjust the display screen contrast so that it is too light or too dark to read. If you cannot read the display, disconnect and then reconnect the line cord to return to the default settings.

Program key

The Program key is automatically assigned to telephones with a Display Module. The Program key allows you to change a variety of display features such as screen format, contrast and language.

The upper right-hand key (key 07) automatically becomes the Program key when a Display Module is configured with the telephone. The Program key is local to the set and shows blank when you print key assignments in LD 20.

On-hook security

The M2016S is a Telephone Security Group Class II-approved telephone designed to provide on-hook security. The M2016S uses relay circuitry that physically disconnects the handset from the telephone circuit when the switchhook is depressed.

On-hook security is indicated by the Message Waiting lamp. The red LED triangle lights steadily when the phone is not secure (handset is off-hook, phone is ringing or any time the handset/piezo relays are connected). The red LED triangle blinks when a message is waiting.

Specifications

The following specifications govern the performance of the M2016S telephone under the environmental conditions described.

Environmental and safety considerations

The M2016S meets the requirements of Electronic Industries Association (EIA) specification PN-1361.

Temperature and humidity

Table 14 "M2016S operating state temperature and humidity requirements" (page 84) and Table 15 "M2016S storage state temperature and humidity requirements" (page 84) show the M2016S temperature and humidity requirements.

Table 14

M2016S operating state temperature and humidity requirements

Temperature range	0° to 50° C (32° to 104° F)
Relative humidity	5% to 95% (non-condensing). At temperatures above 34° C (93° F) relative humidity is limited to 53 mbar of water vapor pressure.

Table 15

M2016S storage state temperature and humidity requirements

Temperature range	-50° to 70° C (-58° to 158° F)
Relative humidity	5% to 95% (non-condensing). At temperatures above 34° C (93° F) relative humidity is limited to 53 mbar of water vapor pressure.

Electromagnetic interference

The radiated and conducted electromagnetic interference meets the requirements of Subpart J of Part 15 of the FCC rules for Class A computing devices.

Line engineering

The maximum permissible loop length is 3500 ft. (915 m), assuming 24 AWG (0.5 mm) standard twisted wire with no bridge taps. A 15.5 dB loss at 256 KHz defines the loop length limit (longer lengths are possible, depending on the wire's gauge and insulation).

The M2016S uses a 6 conductor line cord (A0346862).

Note: Use only the line cord provided with the telephone. Using a cord designed for other digital telephones could result in damage to the M2016S.

Local alerting tones

The M2016S telephone provides four alerting tones and a buzz sound. The system controls the ringing cadence by sending tone-ON and tone-OFF messages to the telephone. The alerting tone cadences cannot be changed from the telephone, but can be altered for individual telephones by software-controlled adjustments.

Alerting tone characteristics

The tone frequency combinations are:

Tone	Frequencies	Warble Rate (Hz)
1	667 Hz, 500 Hz	10.4
2	667 Hz, 500 Hz	2.6
3	333 Hz, 250 H	10.4
4	333 Hz, 250 Hz	2.6

A 500 Hz buzz signal is provided for incoming call notification while the receiver is off-hook.

Power requirements

Power Supply Board

The power supply option consists of a Power Supply Board which mounts inside the telephone, coupled with an external wall-mount transformer which provides power to the Power Supply Board. The Power Supply Board receives its power through pins 1 and 6 of the line cord.

The Power Supply Board connects to the telephone through a 14 pin bottom entry connector.

The Power Supply Board comes factory installed with any configuration of the M2016S.

Local plug-in transformer

A single winding transformer equipped with a 10 ft. (3 m) cord of 22 AWG two-conductor stranded and twisted wire with a modular RJ-11 duplex adapter (refer to [Figure 21 "Configuration of local plug-in transformer" \(page 87\)](#)) can provide the additional power needed to operate the telephone and its options.



CAUTION

Do not plug any equipment (computer, modem, LAN card) other than the M2016S into the RJ-11 transformer adapter, as damage to equipment may result.

120 V transformer (AO367335 or equivalent). The following minimum specifications must be met by this transformer:

Input voltage: 120 V AC / 60 Hz

No load output voltage: 29 V AC maximum

Voltage at rated current: 26.7 V AC minimum

Rated load current: 700 mA

240 V transformer (AO367914 or equivalent). The following minimum specifications have to be met by this transformer:

Input voltage: 240 V AC / 50 Hz

No load output voltage: 29 V AC maximum

Voltage at rated current: 26.7 V AC minimum

Rated load current: 700 mA

Note: You cannot wall mount the telephone over the wall jack when using a transformer, due to the size of the RJ-11 adapter. Hang it above or to the side of the jack and run the line and power cords to it.

Figure 21
Configuration of local plug-in transformer

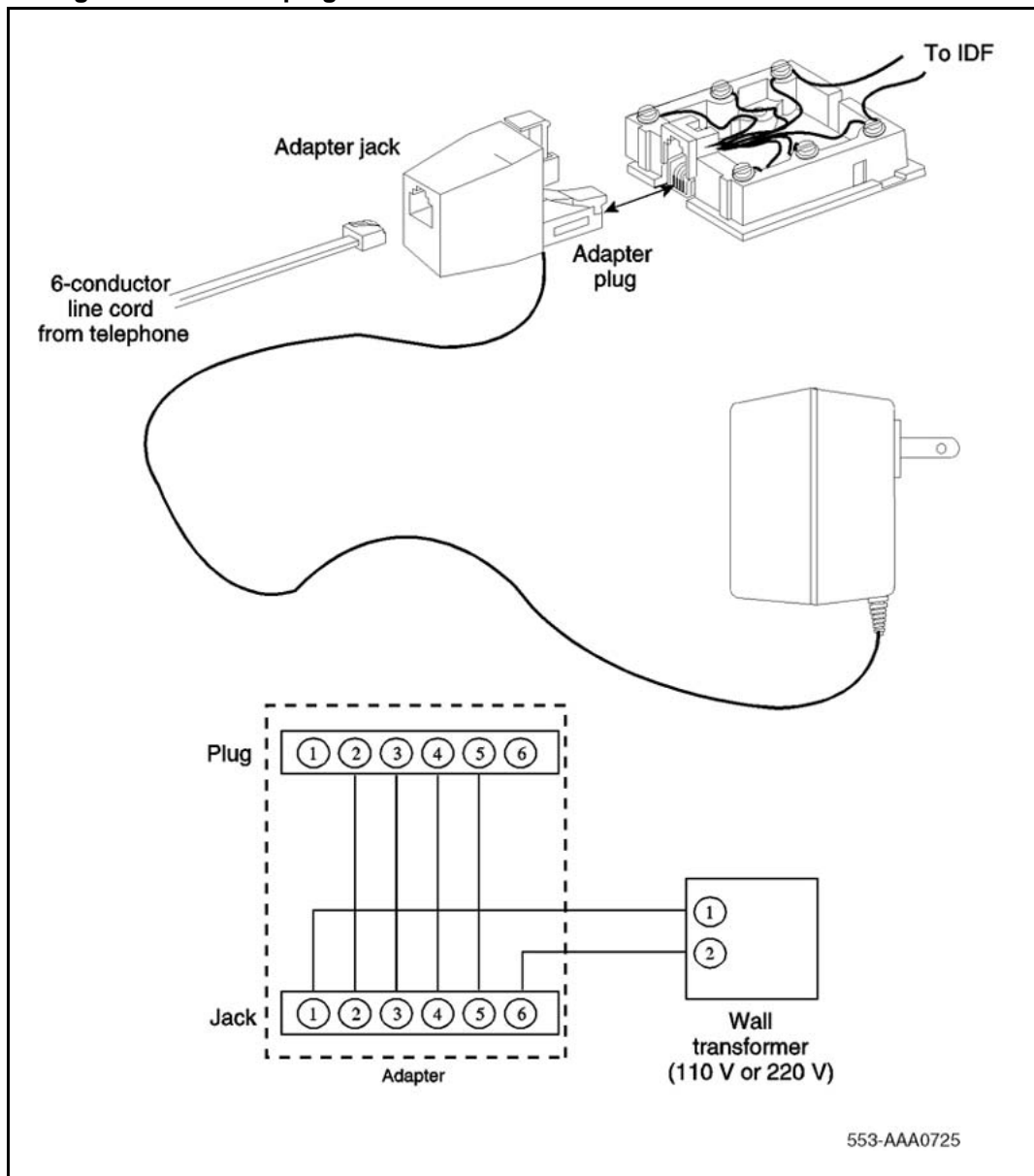

Installation

Packing and unpacking

Use proper care when unpacking the M2016S. Check for damaged containers so that appropriate claims can be made to the transport company for items damaged in transit.

If a telephone must be returned to the factory, pack it in the appropriate container to avoid damage during transit. Remember to include all loose parts (cords, handset, power unit, labels, and lenses) in the shipment.

Installation and removal of M2016S Secure Set

Follow the steps in [Procedure 24 "Installing the M2016S telephone"](#) (page 88) to install the M2016S.

Procedure 24 Installing the M2016S telephone

Step	Action
1	Complete the wiring and cross-connections (loop power) before connecting the telephone to the TELADAPT connector. See Figure 22 "M2016S Secure Set connections" (page 89) and Figure 23 "M2016S cross-connections." (page 90).
2	Place the telephone upside down on a number of sheets of soft, clean paper on a solid, level work surface to prevent damage to movable keys and the telephone's face.
3	Connect the handset cord (5-conductor TELADAPT connectors) to the handset and snap it into place.
4	Connect the other end of the handset cord to the connector in the bottom cover of the telephone. Turn the smooth side of the handset cord up (away from the telephone bottom cover) before tucking it under the restraining tab to ensure that the telephone will sit level on the desk after installation is complete.
5	Connect the line cord to the telephone bottom cover. Route the cord through the channels.
6	Turn the telephone right-side up and place it in the normal operating position.
7	Print the directory number on the designation card. Using a paper clip, remove the number lens from the telephone. Insert the designation card and snap the lens back into place.
8	Designate the feature keys.
9	Insert the line cord TELADAPT connector into the connecting block (jack) and snap it into place.
10	Perform the self-test (see Procedure 25 "M2016S self-test" (page 90)) and acceptance test procedures. See LD 31 in the <i>Software Input Output Administration (NN43001-611)</i> ().

- 11 Supply the user with a Quick Reference Card and all user documentation. Make sure the SPRE number is printed on the Quick Reference Card.

--End--

Figure 22
M2016S Secure Set connections

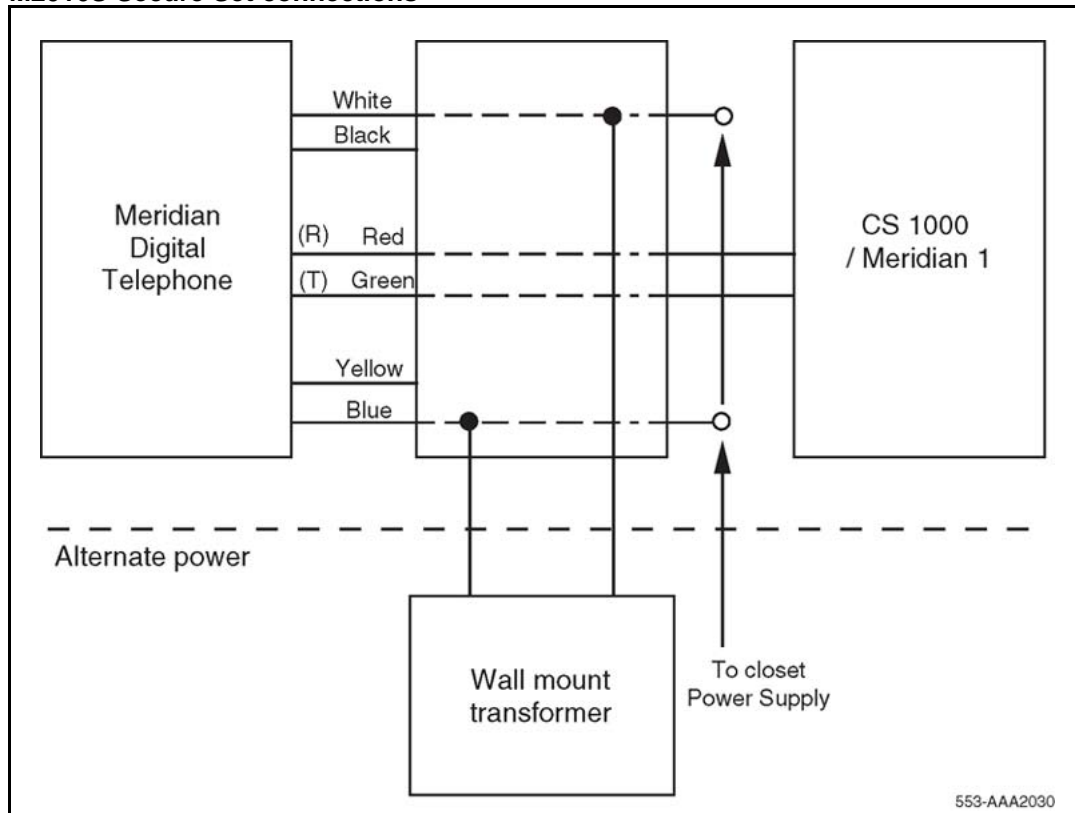
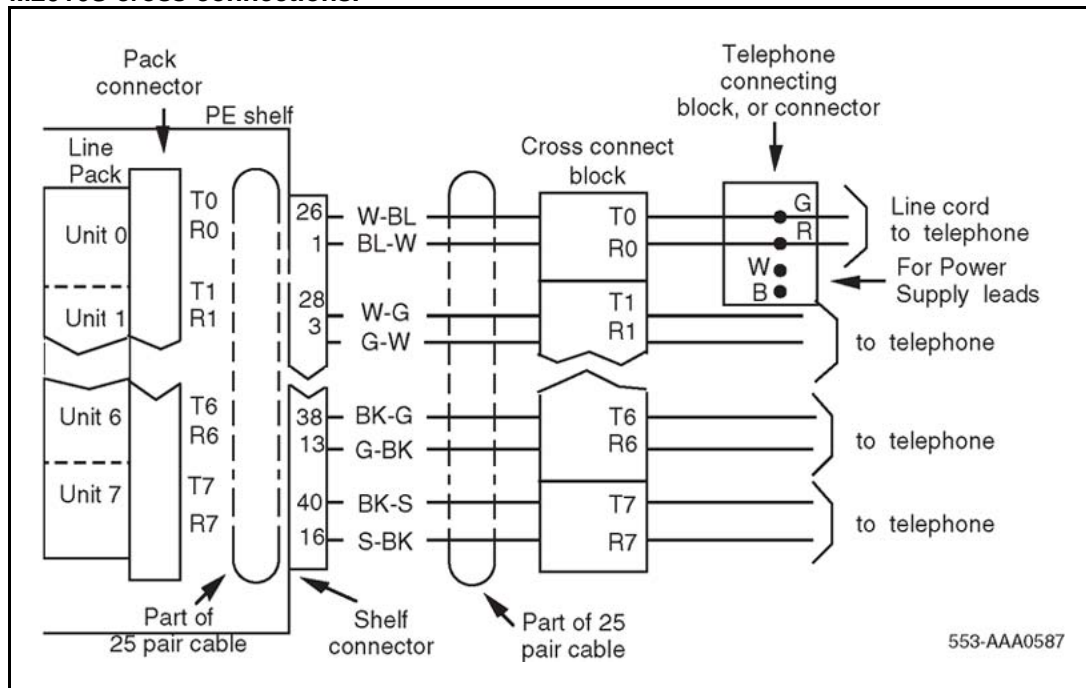

Figure 23
M2016S cross-connections.



The M2016S set has a self-testing capability. Follow the steps in [Procedure 25 "M2016S self-test"](#) (page 90) to perform the self-test after installing an M2016S set, or any of the hardware options, to ensure proper operation.

Procedure 25
M2016S self-test

Step	Action
1	Unplug the line cord from the telephone.
2	While holding down the RLS key, plug in the line cord to the telephone. Let go of the RLS key.
3	Follow the steps in Table 16 "M2016S telephone self-test steps and results" (page 91) to perform the necessary steps and check results.

Table 16
M2016S telephone self-test steps and results

Step	Action	Result
1	Begin test (plug in line cord while holding down the RLS key). The handset is on hook.	Speaker beeps once, all LCDs flash. Message Waiting lamps light steadily. Display reads:LOCAL DIAGNOSTIC MODE PRESS RLS KEY TO EXIT
2	Press each Function key, from zero to fifteen (if there are Key Expansion Modules, continue pressing the Function keys, in any order).	Adjacent LCD goes off when a key is pressed.
3	Press the Hold key.	Speaker beeps.
4	Press each dial pad key.	Speaker beeps each time a key is pressed.
5a	Lift the handset (if applicable). Press the dial pad keys. Replace the handset.	Speaker beeps. Handset beeps.
5b	Plug in the headset (if applicable). Press the dial pad keys. Unplug the headset.	Speaker beeps. Headset beeps.
6	Press the right side of the volume control key. Press the right side of the volume control key. Press the right side of volume control key. Press the right side of the volume control key. Press the right side of the volume control key.	Speaker beeps. Display is filled with dark squares. Speaker beeps. Display is blank. Speaker beeps. Display shows symbols including digits 0–9 and uppercase alphabet Speaker beeps. Display shows symbols including upper- and lowercase alphabet. Speaker beeps. Display shows various symbols.

Table 16
M2016S telephone self-test steps and results (cont'd.)

Step	Action	Result
	Press the right side of the volume control key.	Speaker beeps. Display shows symbols.
	Press the right side of the volume control key.	Speaker beeps. Display is filled with dark squares.
7	Press the RLS key (end of test).	Message Waiting lamp goes off. Display shows idle screen within 10 seconds.

--End--

Designate the telephone

Before designating the M2016S telephone, check the work order for the features enabled and key designations. Designate each key by placing its feature name (from the designation sheet) in the key cap that fits on the key.

Follow the steps in [Procedure 26 "Designating the M2016S telephone" \(page 92\)](#) to designate the M2016S telephone.

Procedure 26 Designating the M2016S telephone

Step	Action
1	Remove the cap from each key requiring a designation.
2	Place the designation in the cap, place the cap over the corresponding key, and gently press down. Repeat for all keys requiring designations.
3	Insert a paper clip into the hole at the left or right end of the designation window.
4	Gently pry the window toward the center and remove, and insert the number tag.
5	Replace the designation window.

--End--

Cross-connect the telephone

Be sure to connect the telephones as shown in [Figure 24 "M2016S telephone cross-connections"](#) (page 94).

Follow the steps in [Procedure 27 "Cross-connecting the telephones"](#) (page 93) to cross-connect the telephones.

Procedure 27 Cross-connecting the telephones

Step	Action
1	Locate the telephone terminations at the cross-connect terminal. Telephone terminations are located on the vertical side of the frame when frame-mounted blocks are used and in the blue field when wall-mounted blocks are used.
2	Connect Z-type cross-connecting wire to the leads of the telephone. See Table 17 "Z-type cross-connecting wire" (page 93) and Table 18 "Inside wiring colors" (page 94).
3	Locate the line circuit card (TN) terminations. Line circuit card (TN) terminations are located on the horizontal side of the distributing frame when frame-mounted blocks are used and in the white field when wall-mounted blocks are used.
4	Run and connect the other end of the cross-connecting wire to the assigned TN terminal block.
--End--	

Table 17
Z-type cross-connecting wire

Size	Gauge	Color	Designation
1 pr	22	Y-BL	Tip
		BL-Y	Ring
3 pr	24	W-BL	Voice T
		BL-W	Voice R
		W-O	Signal T
		O-W	Signal R
		W-G	Power
		G-W	Power

Table 18
Inside wiring colors

Inside wiring colors		Connect to equipment TN
Z station wire	16/25-pair cable	
G	W-BL	First pair Tip
R	BL-W	First pair Ring
BK	W-O	Second pair Tip
Y	O-W	Second pair Ring

Figure 24
M2016S telephone cross-connections

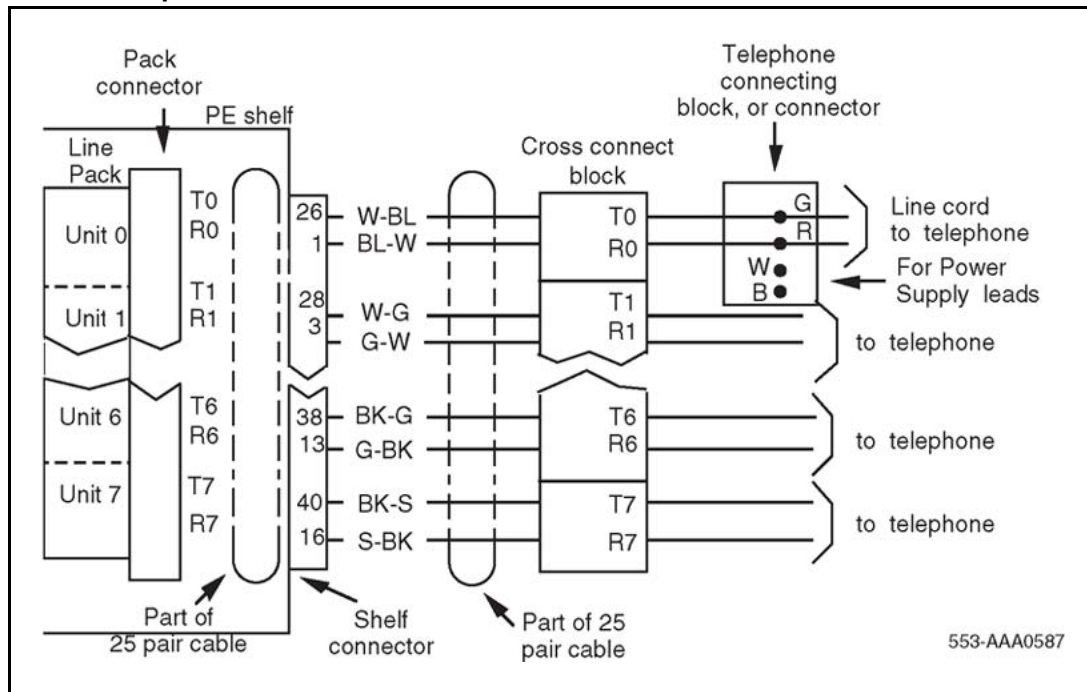

M 3900 description

Contents

This section contains information on the following topics:

- “Introduction” (page 96)
- “Automatic Call Failover” (page 98)
- “Physical description” (page 98)
 - “M3901 Entry Telephone” (page 100)
 - “M3902 Basic Telephone” (page 100)
 - “M3903 Enhanced Telephone” (page 101)
 - “M3904 Professional Telephone” (page 102)
 - “M3905 Call Center Telephone” (page 103)
- “Features” (page 105)
 - “Set-to-Set Messaging” (page 105)
 - “Personal Directory” (page 106)
 - “Corporate Directory” (page 106)
 - “M3900 (single site) Virtual Office” (page 107)
 - “Full Icon Support” (page 107)
 - “Language selection during software installation” (page 110)
 - “Feature keys” (page 110)
- “M3900 accessories and add-ons” (page 114)
 - “Accessory Connection Module” (page 115)
 - “Analog Terminal Adapter” (page 117)
 - “Computer Telephony Integration Adapter” (page 117)
 - “Telephone Application Programming Interface (TAPI) software” (page 118)
 - “Personal Directory PC Utility Software” (page 118)
 - “Accessory Modules” (page 120)
 - “Meridian External Alerter and Recording Interface” (page 120)

- “Alternate key caps for the M3905” (page 121)
- “Handset option for the M3905 Call Center Telephone” (page 121)
- “Headset options” (page 123)
- “Telephone wall-mount kit” (page 123)
- “Full Duplex Handsfree” (page 119)
- “Brandline insert” (page 123)
- “Key descriptions” (page 124)
 - “M3901 key descriptions” (page 124)
 - “M3902 key descriptions” (page 125)
 - “M3903 key descriptions” (page 127)
 - “M3904 key descriptions” (page 129)
 - “M3905 key descriptions” (page 131)

Introduction

The M3900 Series Digital Telephones consists of the following telephones:

- **M3901 Entry Telephone** — an entry-level telephone for occasional use
- **M3902 Basic Telephone** — for manufacturing floor, warehouse, and low telephone use
- **M3903 Enhanced Telephone** — an enhanced telephone for office professionals and technical specialists
- **M3904 Professional Telephone** — a professional telephone for Managers, Executives, Administrative Assistants
- **M3905 Call Center Telephone** — a call center telephone for Agents and Supervisors

The M3900 Series Digital Telephones, X11 Release 25 and later, supports the following features:

- Context-sensitive soft keys (M3903 and M3904)
- Set-to-Set Messaging (M3903 and M3904)
- Corporate Directory (M3903 and M3904)
- M3900 (single site) Virtual Office (M3903 and M3904)
- Display-Based Accessory Module (M3904)
- Flash download of firmware (M3902, M3903, M3904. and M3905)
- Language selection during software installation for M3900 Series Digital Telephones

The M3900 Series Digital Telephones, X11 Release 25.40 (Phase III) and later, supports the following features and enhancements:

- Full Duplex Handsfree (M3904 Phase III)
- System-initiated language selection (M3902, M3903, M3904, and M3905)
- Call Forward enhancements (M3903, M3904, and M3905)
- 31-digit dialing (M3902, M3903, M3904, and M3905)
- Callers List soft key (M3903, M3904, and M3905)
- Redial List soft key (M3903, M3904, and M3905)
- Pause in dialing string (M3902, M3903, M3904, and M3905)
- Special character support (M3902, M3903, M3904, and M3905)
- Headset state support (M3903, M3904, and M3905)
- Set-to-Set Messaging enhancements (M3903, M3904, and M3905)
- One-button feature access to Corporate Directory (M3903, M3904, and M3905)
- Corporate Directory search enhancement (M3903, M3904, and M3905)
- M3900 (single site) Virtual Office enhancements
- Virtual Office clearing of the Callers List and Redial List (M3903 and M3904)
- Automatic log out of Virtual Office
- Speed Call for Virtual Office
- System-initiated language download
- Personal Directory fixed feature key

M3900 Series Digital Telephones communicate with the CS 1000 and Meridian 1 through digital transmission over standard twisted-pair wiring. M3900 Series Digital Telephones can interface with all versions of the Intelligent Peripheral Equipment (IPE) Digital Line Card (DLC). The DLC supports 16 voice ports and 16 data ports. The system software assigns a TN to each port in the system.

For more information on features and telephone operations, refer to the following documents:

- *Meridian Digital Telephones M3901, M3902, M3903, M3904 User Guide (NN42370-107) ()*
- *Meridian Digital Telephones M3902, M3903, M3904 Quick Reference Guide (NN42370-105) ()*
- *Meridian Digital Telephone M3905 Call Center User Guide (NN42370-108) ()*

Automatic Call Failover

The Active Call Failover (ACF) feature enables an M3900 Series Digital Telephone to reregister in the ACF mode during a supported system failure.

The ACF mode preserves the following:

- active media stream
- LED status of the Mute, Handsfree, and Headset keys
- DRAM content

Note: All other elements (feature keys, soft keys and text areas) are retained until the user presses a key or the connection with the Call Server is resumed. If the user presses a key during the failover, the display is cleared and a localized "Server Unreachable" message is displayed.

The M3900 Series Digital Telephone uses this new mode of reregistration only when the Call Server explicitly tells the telephone to do so. M3900 Series Digital Telephones clear all call information if they register to a Call Server or Line Terminal Proxy Server (LTPS) that does not support the ACF feature.

For more information on Active Call Failover, refer to *IP Line Fundamentals (NN43100-500) ()*.

Physical description

These telephones are digital, integrated voice/data telephones with the physical features listed in [Table 19 "M3900 features" \(page 98\)](#).

Table 19
M3900 features

	M3901 entry level	M3902 basic	M3903 enhanced	M3904 professional	M3905 call center
lines supported	1	1	4	12	7

Table 19
M3900 features (cont'd.)

	M3901 entry level	M3902 basic	M3903 enhanced	M3904 professional	M3905 call center
Programmable feature keys	5	3	4	4	4
fixed feature keys	no	Options/ Program, Message (with LED), Transfer (with LED)	Options/ Program, Message, Application, Shift, Call Log	Options/ Program, Message, App lication, Shift, Directory/Log	Supervisor, Emergency, Not Ready, Make Busy, In-calls
fixed keys for call processing	no	Hold, Good-bye, Smart Mute (with LED), Handsfree (with LED)	Hold, Good-bye, Smart Mute (with LED), Headset (with LED), Handsfree (with LED)		Hold, Good-bye, Smart Mute (with LED), Headset (with LED)
Supervisor Observe Key (with LED)	no	no	no	no	yes
fixed application keys	no	Up, Down, Left, Right	Up, Down, Left, Right, Quit, and Copy		
Display	no	(2 x 24): 1 Text Lines, 1 Label Line	(3 x 24): 1 Info Line, 1 Text Lines, 1 Label Line	(5 x 24): 1 Info Line, 3 Text Lines, 1 Label Line	(4 x 24): 1 Info Line, 2 Text Lines, 1 Label Line
Accessory Ports	no	1	2	2	2
Accessories	no	ATA, Computer Telephony Interface Adapter (CT IA), Meridian External Alerter & Recording Interface (MEARI)	ATA, CTIA, MEARI	ATA, CTIA, Display- Based Acce ssory (DBA), MEARI, Full Duplex Hands free (FDHF), Key-Based Accessory (K BA), Personal Directory PC Utility	ATA, CTIA, DBA, MEARI, KBA, Personal Directory PC Utility
Headset	through MPA jack		Direct Connect		

Note 1: All telephones are desk- or wall-mountable, have message waiting LED with visual ringing, and have volume control.

Note 2: The KBA and DBA modules cannot be wall mounted.

M3901 Entry Telephone

The features of the M3901 include:

- one line Directory Number (DN) capability
- five programmable features
- fixed feature keys: Line, Feature, Hold, Goodbye, and Volume control
- feature activation and Message waiting/incoming call status indicator LED
- support for an amplified headset

Figure 25
M3901 Entry Telephone

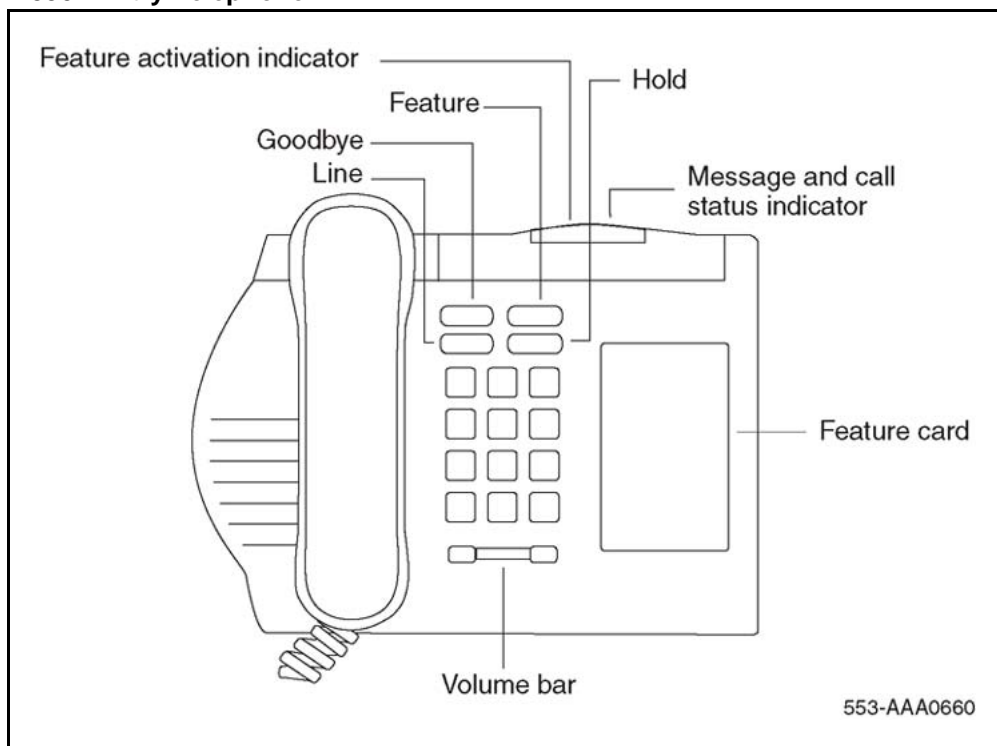

M3902 Basic Telephone

The features of the M3902 include:

- one line Directory Number (DN) capability
- three programmable soft keys (soft-labeled)
- fixed feature keys: Options, Message, Transfer, Goodbye, Hold, "Smart" Mute, and Volume control
- two lines by twenty-four character display area
- Group Listening

- on-hook dialing
- support for an amplified headset
- one accessory port
- handsfree calling option with LED

Figure 26
M3902 Basic Telephone

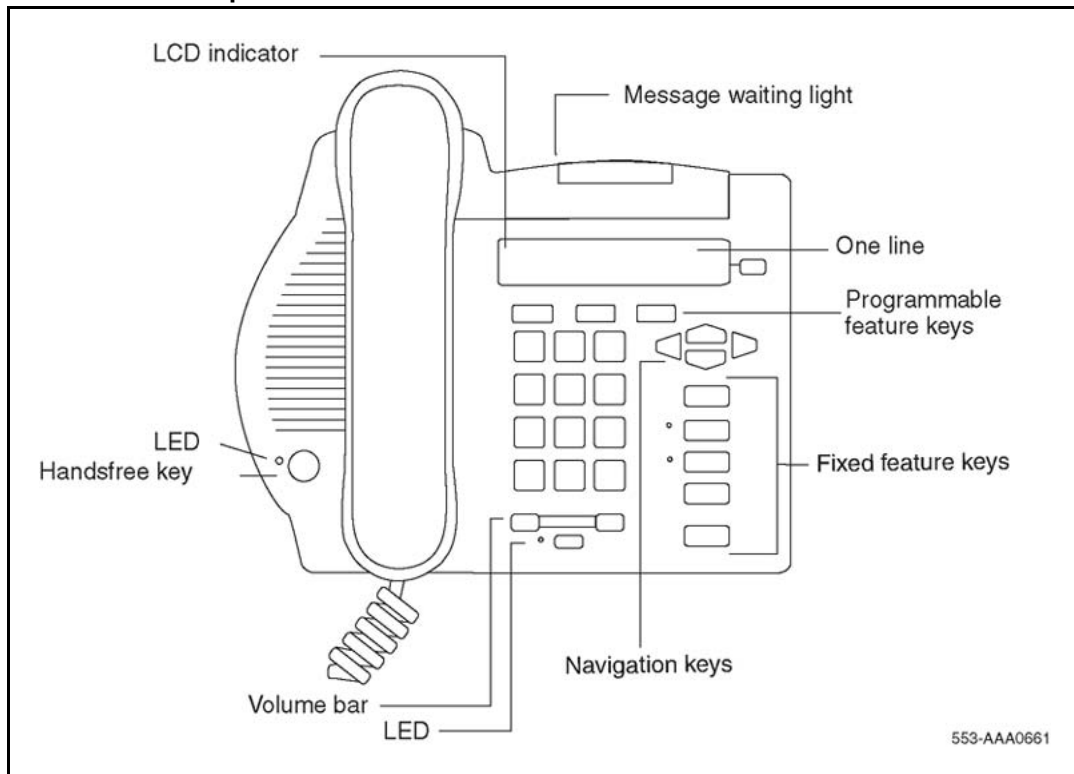

M3903 Enhanced Telephone

The features of the M3903 include:

- two programmable line/feature keys (soft-labeled) which have two layers each, giving the user access to four line/feature keys
- four Context-sensitive soft keys (soft-labeled) that change functionality depending on the features available or the application in use
- Handsfree calling with LED
- fixed feature keys: Goodbye, Message, Call log (including Redial List), Applications, Shift, Goodbye, Hold, "Smart" Mute, and volume control
- Navigation cluster, Quit, and Copy
- three line by twenty-four character display area
- Call Log (includes Redial List)

- Group Listening
- on-hook dialing
- two accessory ports
- support for an amplified or unamplified headset
- Direct connect headset port
- Full icon support (with expansion module)

Figure 27
M3903 Enhanced Telephone

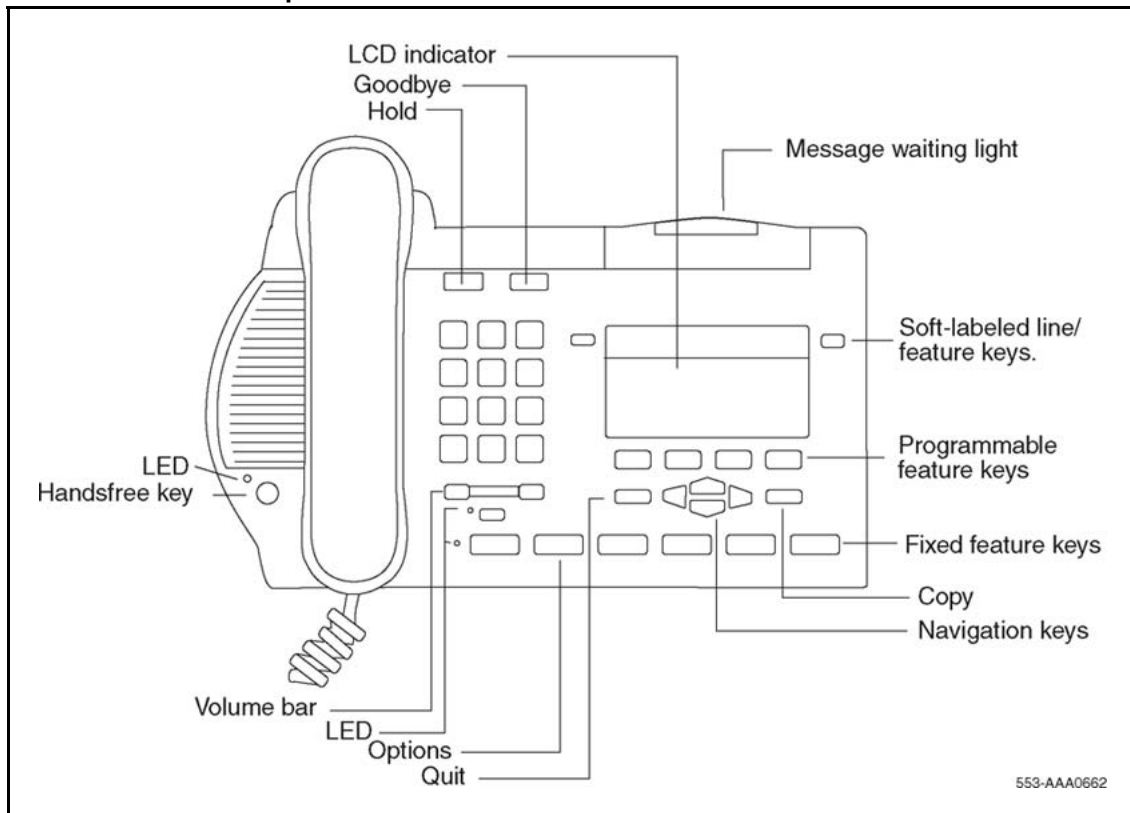

M3904 Professional Telephone

The features of the M3904 telephone include:

- six programmable line/feature keys (soft-labeled) which have two layers each, giving the user access to 12 line/feature keys
- four Context-sensitive soft keys (soft-labeled) that change functionality depending on the features available or the application in use
- Handsfree calling with LED
- fixed feature keys: Options, Message, Directory/Log (including Redial List), Applications, Shift, Goodbye, Hold, "Smart" Mute, Volume control

- Navigation cluster, Quit, and Copy
- five line by twenty-four character display
- Personal Directory
- Call Log (includes Redial List)
- Group Listening
- on-hook dialing
- two accessory ports (support for an amplified/unamplified headset)
- Direct connect headset port
- Full icon support (with expansion modules)

Figure 28
M3904 Professional Telephone

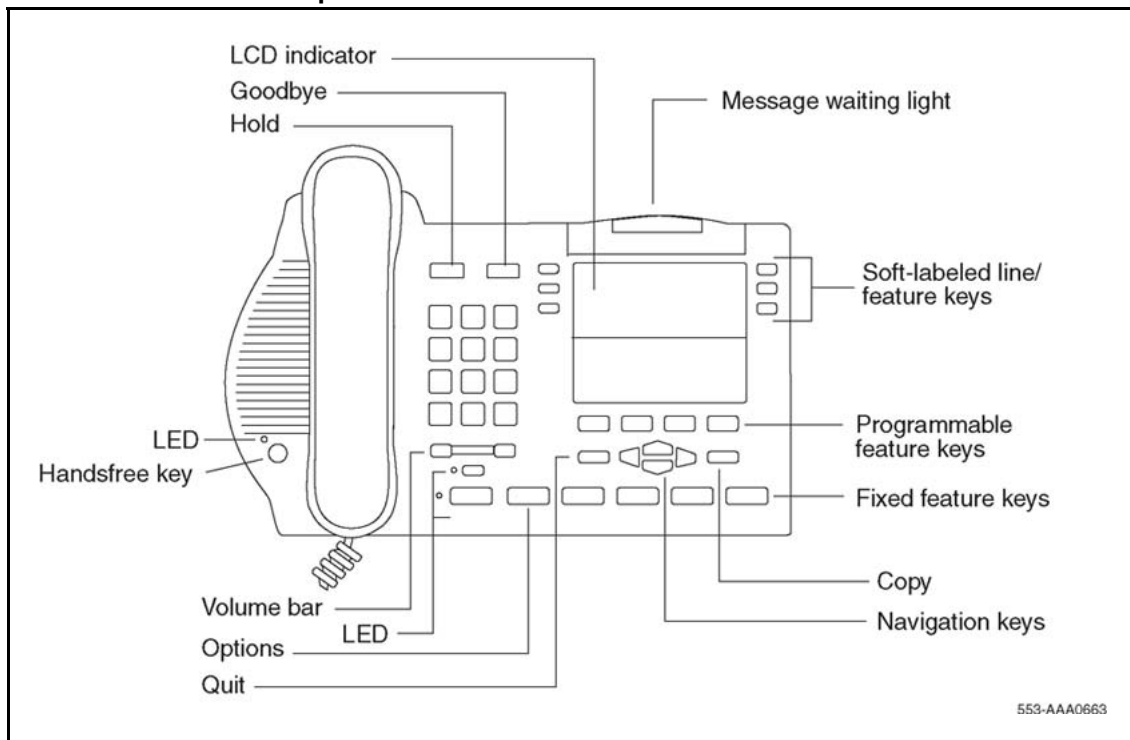

M3905 Call Center Telephone

The features of the M3905 Call Center Telephone include:

- seven programmable line/feature keys (soft-labeled), giving the user access to seven line/feature keys
- four Context-sensitive soft keys (soft-labeled) that change functionality depending on the features available or the application in use

- fixed feature keys with LED: Headset, Supervisor, Emergency, Not Ready, Make Busy, In-Calls, goodbye, Hold, "Smart" Mute, Volume control
- Navigation cluster, Quit and Copy
- four line by twenty-four character display
- an optional headset
- two accessory ports (supports amplified/unamplified headset)
- Supervisor Observe Key with LED
- Full icon support (with expansion modules)
- Supervisor Headset Observe port

Figure 29
M3905 Call Center Telephone

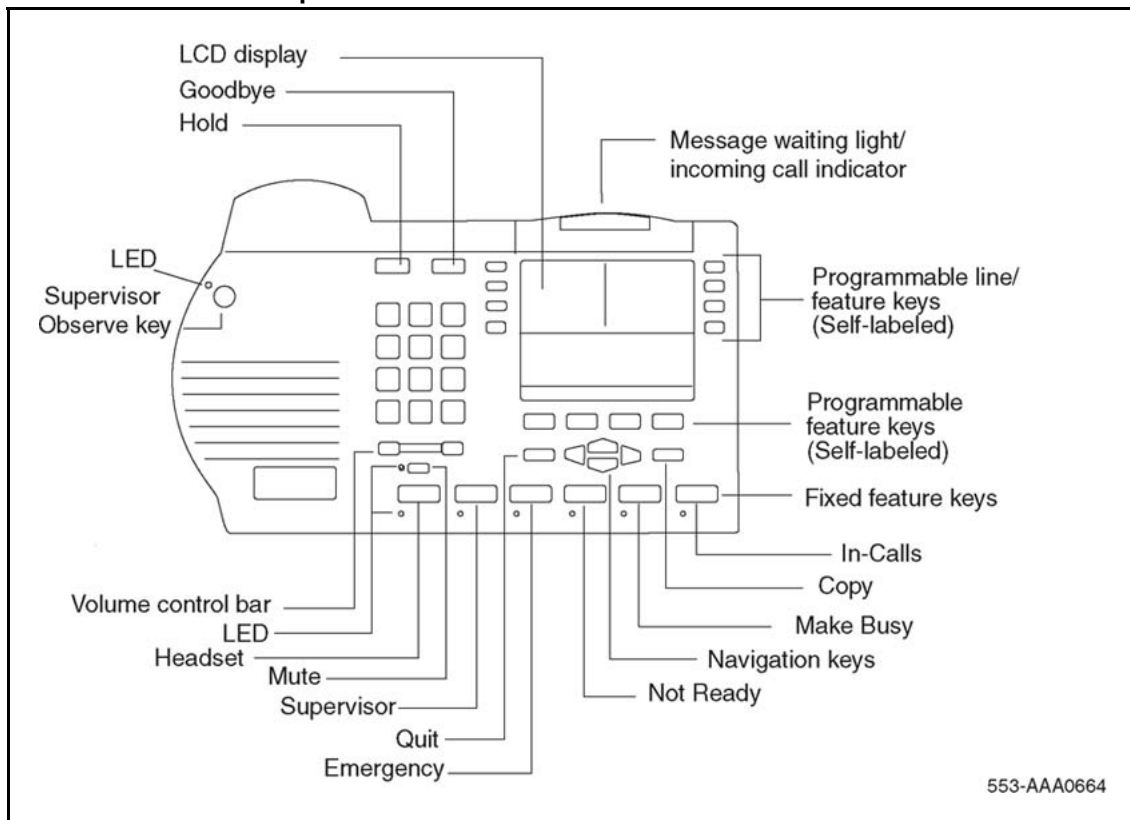

Note: The system administrator can configure four of the bottom six fixed feature keys (Make Busy, Not Ready, Supervisor and Emergency) to feature keys that suit the business needs of the Call Center user.

Features

The following section describes the following key features supported on M3900 Series Digital Telephones:

- Set-to-Set Messaging
- Personal Directory
- Corporate Directory
- Full Icon Support
- Language selection during software installation
- Feature keys

Set-to-Set Messaging

The Set-to-Set Messaging feature provides a visual message from one M3900 telephone to another M3900 telephone when a user makes a call to that telephone. The user on an M3903, M3904, or M3905 set enters the Set-to-Set Messaging text at the telephone. Set-to-Set Messaging is accessed through the Applications key.

The maximum length for Set-to-Set Messaging text is 24 characters (one line of the set display).

[Table 20 "Examples of message text" \(page 105\)](#) shows examples of Set-to-Set Messaging text.

Table 20
Examples of message text

OUT TO LUNCH
BACK TO WORK: 4 Dec 02
BACK TO OFFICE: Jan 03
WILL REPLY AFTER 1 PM
BACK @ 4:00 PM
NOT IN TODAY
RETURN SOON -- 8:10 AM
GONE FOR THE DAY

The user may have only one Set-to-Set message on their telephone at a time. To activate Set-to-Set Messaging, the user must first define a message. If password protection is active for the M3900, it also applies to Set-to-Set Messaging.

If the Multiple Appearance Redirection Prime (MARP) feature is active, then MARP determines which DNs receive the Set-to-Set Message. If MARP is not active, then Multiple Appearance Directory Number (MADN) determines which DNs configured on the telephone receive the Set-to-Set Message.

To use Set-to-Set Messaging, the M3903, M3904, or M3905 telephone must have:

- Set-to-Set Messaging feature Class of Service enabled
- Set-to-Set Message text created
- Set-to-Set Messaging feature enabled

When Set-to-Set Messaging is active, the caller hears an audible tone and the Set-to-Set Message appears on their display. The caller then hears ringback and the call goes to voice messaging. If the called set is busy, a call waiting tone is heard by the called party.

Personal Directory

With M3900 Phase III, press the **Directory/Log** fixed feature key to access the Personal Directory on M3904 telephones. On M3905 telephones, press the **Directory** self-labeled programmable feature key. You do not have to press the **Select** key after pressing the **Directory/Log** or **DIR/LOG** key. Once you press the **Directory/Log** or **DIR/LOG** key, you can immediately begin a search using the dial pad keys, provided that Personal Directory was highlighted in the selection list.

Note: M3900 Phase III allows you to perform a three-letter search in the Personal Directory.

Corporate Directory

The M3903, M3904, and M3905 telephones provide access from the telephone to a corporate-wide directory. The Corporate Directory is accessed through the **Applications** Key. The Corporate Directory allows users to:

- search by name
- view additional information on each entry
- dial from the Corporate Directory
- copy and paste an entry into the Personal Directory (M3904)
- view an alphabetical listing of entries by last name (system generated)

Note: When names are copied to the Personal Directory (M3904), the names are listed by first name.

The system administrator can configure Optivity Telephony Manager (OTM) to download the directory database manually or automatically to the system.

Operating parameters

The user must have an M3903, M3904, or M3905 telephone to support the Corporate Directory feature. To access the Corporate Directory from the telephone, the user must have the Corporate Directory Class of Service enabled.

When the Corporate Directory is being updated with new data, the user cannot access the Corporate Directory. The user exits the Corporate Directory by pressing the **Quit** key or the **Applications** key.

The OTM utility gathers data from OTM databases and downloads it to the system. To use Corporate Directory, OTM must be installed.

M3900 (single site) Virtual Office

The Virtual Office feature allows users to log in to a designated M3903 or M3904 Digital Telephone and use their individual telephone configurations at that telephone. The calls to the user's primary DN are routed to the Virtual Office Host Terminal where the Virtual Office worker is logged in.

For further information on Virtual Office, refer to ["M3900 \(single site\) Virtual Office" \(page 135\)](#).

Full Icon Support

The M3900 Full Icon Support feature enables distinct icons and flashing cadences for the display of different call states. These icons are displayed for the Directory Number (DN) keys on the Phase II and Phase III M3903 and M3904 telephones, as well as the Phase III M3905 telephones.

The M3900 Full Icon Support feature requires a minimum of Release 9 of the Key-Based Accessory module (KBA).

The icons also display on the Key-Based Accessory module and the Display-Based Accessory module. This feature allows the user to quickly determine the call state of a DN, instead of viewing just the flashing cadence of a single generic icon to determine the call state.

The functions displayed with the Full Icon Support feature are: I-Ringing, I-Active, U-Active, I-Hold, and U-Hold. The icons appear on the LCD displays located next to the DN keys. The scenarios for these icons are as follows:

- **I-Ringing:** The I-Ringing icon is displayed on the ringing DN of a set that is being called.
- **I-Active:** The I-Active icon is displayed on DNs on telephones in the active call state.
- **U-Active:** The U-Active icon appears on the MADN of a set when another set on the MADN is in the active call state.
- **I-Hold:** The I-Hold icon appears on the DN of the set that has a call on hold.
- **U-Hold:** The U-Hold icon appears on the MADN of a set when another set on the MADN has a call in the hold state.

The Ringing, I-Hold, U-Hold, and Active DN keys, represented by a generic icon in previous releases, displays the following icons with the Full Icon Support feature:



**Table 21
Icons and Cadences**



Call/Feature state	DN key icon	Cadence
Ringing		Flash
I-Hold		Wink
U-Hold		Flicker

Table 21
Icons and Cadences (cont'd.)

Call/Feature state	DN key icon	Cadence
I-Active		On
U-Active		On

Feature interactions

There are no feature interactions associated with this feature.

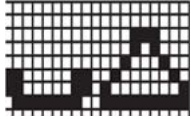
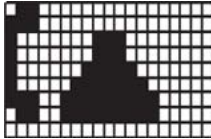
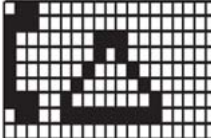
Feature packaging

The M3900 Full Icon Support feature requires the following packages:

- M3900 Full Icon Support (ICON_PACKAGE) package 397
- Digital Sets (DSET) package 88

Feature implementation

Use LD 17 to enable M3900 Full Icon Support:

Table 22
LD 17 - Enable M3900 Full Icon Support

Prompt	Response	Description
REQ	CHG	Change existing data
TYPE	PARM	System Parameters
.....		
ICON	(NO) YES	Enable the M3900 Full Icon Support feature NO = Disable the M3900 Full Icon Support feature

Feature operation

No specific operating procedures are required to use this feature.

Language selection during software installation

The system software installer selects one of seven language sets to be installed on the system. This selection determines the languages available to M3900 Series telephone users. The language sets are as follows:

1. **Global 10 Languages** — English, French, German, Spanish, Swedish, Italian, Norwegian, Brazilian Portuguese, Finnish, Japanese Katakana
2. **Western Europe 10 Languages** — English, French, German, Spanish, Swedish, Norwegian, Danish, Finnish, Italian, Brazilian Portuguese
3. **Eastern Europe 10 Languages** — English, French, German, Dutch, Polish, Czech, Hungarian, Russian, Latvian, Turkish
4. **North America 6 Languages** — English, French, German, Spanish, Brazilian Portuguese, Japanese Katakana
5. Spare Group A
6. Spare Group B (duplicate of set 4)
7. Packaged Languages

During the software installation process, the installer selects one of the above seven Peripheral Software DownLoad (PSDL) files. Refer to the following documents for more information on software installation:

- *Communication Server 1000M and Meridian 1 Small System Installation and Commissioning (NN43011-310) ()*
- *Communication Server 1000M and Meridian 1 Large System Installation and Commissioning (NN43021-310) ()*
- *Communication Server 1000S: Installation and Configuration (NN43031-310) ()*
- *Communication Server 1000E Installation and Commissioning (NN43041-310) ()*

Feature keys

The fixed feature keys (see [Table 23 "Fixed Feature Key text and icon labels" \(page 111\)](#)) are the feature keys on the M3900 Series Digital Telephone that are pre-labeled with the assigned feature. The fixed feature keys appear on the telephone with text or icon labels. Telephones with icon labels are only available in specific market regions.

Table 23
Fixed Feature Key text and icon labels























Feature	Text Key Label	Icon Key Label
Goodbye		
Hold		<p>or</p>  
Mute		
Handsfree		
Volume		
Headset		
Options		
DN line		
Feature (M3901)		
Message		
Directory/Log (M3904)		
Note: Icon key labels are available in specific markets areas.		

Table 23
Fixed Feature Key text and icon labels (cont'd.)



































Feature	Text Key Label	Icon Key Label
Call Log (M3903)		
Shift		
Application		
Navigation		
Copy		
Quit		
Transfer (M3902)		
InCalls (M3905 Call Center)		
Not Ready (M3905 Call Center)		
Make Busy (M3905 Call Center)		
Call Supervisor (M3905 Call Center)		
Answer Agent (M3905 Call Center)		
Note: Icon key labels are available in specific markets areas.		

Table 23
Fixed Feature Key text and icon labels (cont'd.)

Feature	Text Key Label	Icon Key Label
Activity Code (M3905 Call Center)		
Answer Emergency (M3905 Call Center)		
Emergency (M3905 Call Center)		
Observe Agent (M3905 Call Center)		
Display Queue (M3905 Call Center)		
Note: Icon key labels are available in specific markets areas.		

Programmable line/feature keys (soft-labeled)

The programmable line/feature keys (soft-labeled) are the keys located at the left and right sides of the upper section of the display area. Soft-labeled keys are keys that are labeled on the telephone's LCD display.

The user-defined programmable line/feature keys of the M3900 Series Digital Telephones deliver the ability for a user to change the LCD labels of their set keys (with the exception of the primary Directory Number key) to meet their business needs. The M3900 soft-labeling is similar to the previous digital telephones, which required paper labels to be created and inserted under clear key caps. By design, this information is stored in the set itself. When a line or feature key programming is changed, the user-defined soft label is replaced with the default label.

The programmable line/feature key (soft-labeled) provides two layers of functionality on the M3903 and M3904. Pressing the Shift key allows access to the second layer. The two layer keys on the M3903 and M3904 provide the user access to two lines/features per key. For example, the M3904 has six programmable line/feature keys (soft-labeled), which provide the user with 12 line/feature keys accessible on the six keys.

Soft Keys (soft-labeled)

The soft keys (soft-labeled) are the three (M3902) or four (M3903, M3904, and M3905) keys located below the display on the M3900 Series Digital Telephones. The labels and corresponding functionality of these keys change depending on the features available or the application in use.

Programmable Features

For feature key assignment information, refer to:

- [Table 26 "M3901 key description" \(page 124\)](#)
- [Table 27 "M3902 key description" \(page 126\)](#)
- [Table 28 "M3903 key description" \(page 127\)](#)
- [Table 29 "M3904 key description" \(page 129\)](#)
- [Table 30 "M3905 key description" \(page 131\)](#)

M3900 accessories and add-ons

[Table 24 "M3900 series telephone accessories compatibility" \(page 114\)](#) lists the accessories and optional hardware available for each M3900 Series Digital Telephone.

Table 24
M3900 series telephone accessories compatibility

Accessory	X11 release introduced	M3900 phase introduced	M3902	M3903	M3904	M3905
Accessory Connection Module (ACM)			Supports	Supports	Supports	Supports
Analog Terminal Adapter (ATA) ¹	Release 24.24	Phase I	Supports	Supports	Supports	Supports
Computer Telephony Integration Adapter (CTIA)	Release 25.40	Phase III	Supports	Supports	Supports	Supports ²

1. In the EMEA market region, the ATA is not supported on the M3902, M3903, or M3905.

2. M3905 Phase III firmware is required to support the Personal Directory PC Utility, DBA, and CTIA accessories.

3. M3904 Phase III firmware and hardware are required to support Full-Duplex Handsfree accessory.

Table 24
M3900 series telephone accessories compatibility (cont'd.)

Accessory	X11 release introduced	M3900 phase introduced	M3902	M3903	M3904	M3905
Display-Based Accessory Module (DBA)	Release 25.10	Phase II	NA	NA	Supports	Supports "2" (page 114)
Key-Based Accessory Module (KBA)	Release 24.24	Phase I	NA	NA	Supports	Supports
Meridian External Alerter and Recording Interface (MEARI)	Release 24.24	Phase I	Supports	Supports	Supports	Supports
Full Duplex Handsfree (FDHF)	Release 25.40	Phase III	NA	NA	Supports ³	NA
Personal Directory PC Utility	Release 24.24	Phase I	NA	NA	Supports	Supports "2" (page 114)
Headset (non-amplified) connects through the direct connect headset jack			NA	Supports	Supports	Supports
Headset (amplified) connects through the headset jack			Supports	Supports	Supports	Supports

1. In the EMEA market region, the ATA is not supported on the M3902, M3903, or M3905.

2. M3905 Phase III firmware is required to support the Personal Directory PC Utility, DBA, and CTIA accessories.

3. M3904 Phase III firmware and hardware are required to support Full-Duplex Handsfree accessory.

Accessory Connection Module

The Accessory Connection Module (ACM) provides the interface for adding the Analog Terminal Adapter (ATA), Meridian External Alerter and Recording Interface (MEARI), Computer Telephony Interface Adapter (CTIA), Personal Directory PC Utility, and Full Duplex Handsfree (FDHF).

The ACM is available for the M3902, M3903, M3904 and the M3905. It also acts as a footstand for the telephone. The ACM and its accessory cartridges cannot be used in wall-mount applications.

The ACM requires one of the following wall transformers to power any of the accessory cartridges:

- 110 V wall transformer (NTMN80AA)
- EU (EMEA) 230 V wall transformer (NTHC09AA)
- UK 230 V wall transformer (NTHC08AA)

You must order the wall transformer separately from your Nortel distributor to power the ACM and/or the M3900 accessories.

[Table 25 "Accessory compatibilities" \(page 116\)](#) shows the compatibilities of M3900 Series Digital Telephone accessories.

Table 25
Accessory compatibilities

	ATA	CTIA	Personal Directory PC Utility	FDHF	MEARI	KBA	DBA
ATA	N/A	YES	YES	NO	YES	YES	YES
CTIA	YES	N/A	YES ¹	N/A	NO	YES	YES
PC Utility	YES	YES ¹ (page 116)	N/A	YES	YES	YES	YES
FDHF	NO	YES	YES	N/A	YES ²	N/A	N/A
MEARI	YES	YES	YES	YES ² (page 116)	N/A	YES	YES
KBA	YES	YES	YES	YES	YES	N/A	NO
DBA	YES	YES	YES	YES	YES	NO	N/A
Note: Not all of the above accessories are supported on all telephones in the M3900 Series portfolio. Refer to Table 24 "M3900 series telephone accessories compatibility" (page 114) .							
1. If either the CTIA or the PC Utility cartridge is installed, no additional cartridge is required. The applicable software may be purchased separately.							
2. The Meridian External Alerter and Recording Interface can only be used for external alerting when used with the Full Duplex Handsfree. Call Recording is not supported.							

Accessory keying

A maximum of two cartridge accessories can plug into the slots at the rear of the ACM stand. The ports provide access to a SIDL/SDI port, USART port, and GPIO0. Two accessories cannot access the same serial port. The mechanical keying prevents this situation from occurring. Refer to [Figure 30 "M3900 Series mechanical keying"](#) (page 117) for a better understanding of mechanical keying.

Figure 30
M3900 Series mechanical keying

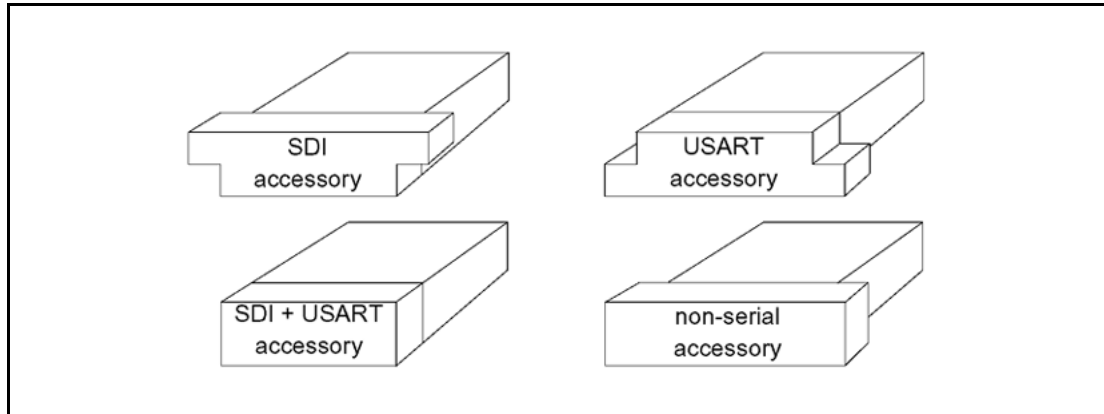

Analog Terminal Adapter

The Analog Terminal Adapter (ATA) lets you connect an analog device such as a fax machine or modem to your telephone. You can have simultaneous use of the telephone and the analog device. The ATA is available for the M3902, M3903, M3904 and the M3905 models. In the EMEA market region, the ATA is supported only on the M3904.

Computer Telephony Integration Adapter

The Computer Telephony Integration Adapter (CTIA), along with the desktop TAPI Service Provider software, provides an interface to connect a PC to the M3900 Series Digital Telephone. This enables PC applications to monitor or control the M3900 telephone for first-party (individual) call control type applications. The CTIA integrates the PC and the telephone, allowing more effective management of calls using PC applications such as Microsoft Outlook^a.

An RS-232C cable is required to connect the PC to the CTIA. The CTIA connects to the M3900 Series Digital Telephone through the Accessory Connection Module (ACM). The CTIA is a small cartridge accessory and can be inserted into either the small or large footstand opening.

The CTIA is powered through the ACM. The ACM receives power through the telephone through the telephone line cord which is connected to a Teladapt wall transformer power supply (see [Figure 37 "Wall transformer](#)

connections" (page 151) on [Figure 37 "Wall transformer connections" \(page 151\)](#)). Check with your Nortel distributor for the recommended wall transformer for the M3900 accessories. Install the Accessory Connection Module (ACM) into your M3900 Series Digital Telephone (refer to the ACM Installation Sheet) before you install your CTIA.

The CTIA cartridge provides the user:

- connectivity to the PC
- voice call control, using the TAPI SP software included with the CTIA

Telephone Application Programming Interface (TAPI) software

The Desktop TAPI Service Provider software accompanies your CTIA Cartridge. The Desktop TAPI Service Provider software interprets the information sent to the telephone and passes it on to a TAPI application. TAPI-compliant applications usually support activities such as placing, answering, holding transferring, and conferencing calls. This can include the information presented to the set display.

Personal Directory PC Utility Software

In addition to the TAPI software which is included with the CTIA, you may wish to purchase the Personal Directory PC Utility Software. The Personal Directory PC Utility software uses your CTIA Cartridge to connect your PC and M3904 telephone so that you may exchange data between your PC and your telephone's directory.

The Personal Directory PC Utility software provides a faster, easier way to create or modify a Personal Directory on the M3904 and M3905 telephones. You can enter names and numbers into a Personal Directory file on your Personal Computer (PC). You can download (program) the PC file directly to the M3904 and M3905 telephones. You can upload (read) a directory from the M3904 and M3905 telephones to your PC to modify the directory.

An RS-232C cable is required to connect the PC to the Personal Directory PC Utility Interface Cartridge. The cartridge connects to the M3900 Series Digital Telephone through the Accessory Connection Module (ACM). The Personal Directory PC Utility Interface Cartridge is a small cartridge accessory and can be inserted into either the small or large footstand opening.

The Personal Directory PC Utility Interface Cartridge is powered through the ACM. The ACM receives power through the telephone via the telephone line cord which is connected to a Teladapt wall transformer power supply (see [Figure 37 "Wall transformer connections" \(page 151\)](#) on [Figure 37 "Wall transformer connections" \(page 151\)](#)). Check with your

Nortel distributor for the recommended wall transformer for the M3900 accessories. You must install the Accessory Connection Module (ACM) into your M3900 Series Digital Telephone (refer to the ACM Installation Sheet) before you install your Personal Directory PC Utility Interface Cartridge.

Note: The CTIA Cartridge and the Personal Directory PC Utility Interface Cartridge are identical. If both products are to be used, only one cartridge is required.

The Personal Directory PC Utility supports the following languages: English, French, Spanish, German, Danish, Portuguese, Italian, Norwegian, Swedish, Finnish, Dutch. The default language is English.

Full Duplex Handsfree

The Full Duplex Handsfree (FDHF) functionality allows simultaneous two-way communication during a handsfree call. Regular handsfree operation is half-duplex. Only one party can be heard at a time. FDHF allows a speaker to be aware when another party on the call is also speaking.

Note: To ensure optimal functionality, the receive audio level is attenuated during the FDHF mode when both parties are speaking. As a result, fluctuations in the receive volume can occur during FDHF calls. If this occurs, do not increase the set speaker volume, as this may cause the set to revert to half-duplex operation.

For Full Duplex Handsfree functionality, you require an M3904 Phase III set equipped with an FDHF cartridge.

Note: Phase III hardware is required since design modifications were made to the M3900 Series Digital Telephones to accommodate the FDHF functionality.

The FDHF functionality requires the following hardware (minimum vintages listed):

- M3904 Phase III set (NTMN34GA)

Note: NTMN34TA is the M3904 Phase III Icon set.

- Full Duplex Handsfree cartridge (NTMN72xx)
- Accessory Connection Module (ACM) (NTMN71xx)
- One of the following wall transformers to power the FDHF cartridge:

- 110 V wall transfer (NTMN80AA)
- EU (EMEA) 230 V wall transformer (NTHC09AA)
- UK 230 V wall transformer (NTHC08AA)

Meridian External Alerter and Recording Interface

The Meridian External Alerter and Recording Interface (MEARI) provides an interface for a remote ringer device installed in a location separate from your M3902, M3903, M3904, or M3905 telephone. The MEARI provides access to a standard, off-the-shelf remote ringer, call status relay, audio recorder or visual indicator.

You can program the MEARI to activate a ringer (or light) when the telephone rings or when the telephone is in use (off hook). A call to any DN configured on the telephone triggers the alerter. The MEARI alerts to one active call at a time. If the telephone is already active on a call, a second call will not activate MEARI.

If used on the M3904 in conjunction with the Full Duplex Handsfree accessory, the MEARI can be used only for external alerting, not recording.

Note: The MEARI is an interface only. The ringer, light, buzzer, or other alerting device is to be obtained through a third-party vendor of the customer's choice.

Accessory Modules

The Display-Based and Key-Based Accessory Modules are mutually exclusive. A set with one or two KBAs configured or installed cannot have a DBA.

Both the KBA and DBA modules are loop-powered and do not require the 110V wall transformer. Neither the KBA nor the DBA modules is supported for wall-mount applications.

Key-Based Accessory Module

The Key-Based Accessory Module (KBA) attaches to the M3904 and M3905 Digital Telephones. The KBA provides 22 additional line/feature keys. These keys are equipped with clear key caps and paper labels. You can attach a maximum of two KBAs to the M3904 and M3905.

The KBA requires an additional footstand kit to secure the module(s) to the set. If using one KBA, Kit 1 must be ordered. If installing two KBAs on the same set, Kit 1 and Kit 2 must be used. If a second KBA is being installed on a set with an existing KBA and stand, only Kit 2 is required.

Display-Based Accessory Module

The Display-Based Accessory Module (DBA) provides additional line/programmable feature keys (soft-labeled) for the M3904 and M3905 telephones. The DBA supports up to 3 layers of 8 additional keys for a total of 24 keys.

Note: Refer to [Table 24 "M3900 series telephone accessories compatibility" \(page 114\)](#) for a list of the telephones with which the DBA module is compatible.

A Page fixed key located on the DBA allows a user to switch between the three layers of soft-labeled programmable feature keys. Visual indication is also provided to indicate which page (or layer) of soft-labeled programmable feature keys is in use. Feature activation and deactivation on the DBA keys is the same as the programmable feature keys on the M3904 and M3905.

Note: If an incoming call is posted to a DN key located on page 2 or 3 of the DBA, the unit does not automatically scroll to that page. This prevents the disruption of other user operations already in progress.

The user may change the feature key labels by selecting "Change feature key label" from the Options list on the M3904 or M3905.

The DBA is supported only on the M3904 and M3905. You can attach a maximum of one DBA to an M3904 or M3905 telephone.

The DBA comes with its own attachment arm and plug to secure the accessory module to the set.

Alternate key caps for the M3905

The M3905 Call Center Telephone provides an alternate key cap kit to customize your M3905 telephone to fit your business needs. Use the key cap tool to remove any of the middle four fixed programmable keys, located at bottom front of the M3905, and replace them with alternate keys. The alternate key caps include: Answer Emergency, Answer Agent, Activity Code, Call Agent, Observe Agent, and Display Queue.

Handset option for the M3905 Call Center Telephone

The M3905 Call Centre Telephone is designed to have a headset always present. The M3905 does not come equipped with a headset. The optional Handset Kit (NTMN18AA) is a hardware package that can be added to the M3905 and includes a headset, handset cord, and an add-on handset cradle. To install the handset cradle, uncover the hookswitch by removing the plate at the top front of the telephone, and snap the handset cradle in over this area.

A headset, handset, or both must be plugged into the M3905 when ACD queue login is required. Login to an ACD queue is not a supported operation when neither a headset nor a handset is plugged into the M3905. If neither a headset nor a handset are present, and the hookswitch is uncovered, it may still be possible to login to the ACD queue. This could result in calls being presented to the M3905 without being answered. Therefore, care must be taken to ensure a headset or handset is plugged in before queue login is attempted. As of CS 1000 Release 4.5, if the hookswitch remains covered, or if the handset is properly cradled on the hookswitch, login cannot occur even if a headset is not plugged in.

The handset can be used without the headset plugged in. However, some functionality, including the ability to login to the ACD queue, can vary with the version of firmware installed on the M3905 and the release of software running on the system. Refer to [“M3900 Flash Download” \(page 177\)](#) for details on how to determine the firmware version installed on an M3900 Series Digital Telephone.

Earlier software releases and previous versions of M3900 firmware deliver different operations. Phase I and Phase II M3905 telephones report a headset present even if one is not. This allows a handset to be used without a headset plugged in. The handset can plug into the handset port and ACD queue login proceeds normally. Login can occur even if neither a handset or headset is present.

Phase III telephones correctly recognize the presence or absence of a headset. If a headset is present on a Phase III M3905, then a handset can also be used. If a headset is not present, a handset must be plugged into the headset port to allow normal ACD queue login. However, when the handset is in the headset port, the system does not accept signals from the telephone’s hookswitch. Hanging up the handset (going ONHOOK) does not disconnect calls. The Goodbye key must be used to release a call.

As of Succession 3.0 and later software, when the M3905 is in use, the system software checks the headset port to verify that a headset, or some other device, is plugged in. If no device is present and the HEADSET button is off, the system assumes a handset is being used in the handset port of the set. The system is then prepared to respond to signals from the M3905 telephone’s hookswitch, even though a headset is not present. M3905 firmware version 8.9 or later is required to send these hookswitch signals to the system. This allows the set to login to the ACD queue when the handset is taken OFFHOOK, and calls to be disconnected when the handset is hung up (placed ONHOOK).

Headset options

The M3901, M3902, and M3904 supports an amplified headset when the headset connects to the handset jack.

On a M3905, plug the amplified headset into the headset port. Do not plug an amplified headset into the handset jack.

The M3903, M3904 and M3905 have a dedicated headset jack which supports a non-amplified headset. The M3903, M3904 and M3905 have a Headset fixed feature key to turn the Headset on and off.

Contact your Nortel distributor for qualified headset equipment.

Headset considerations

Test the headset with the telephone before using. In a noisy environment, an amplified headset is an option. When the amplified headset is used, two choices of volume control are available: the rocker control on the telephone and the switch on the headset. The user should adjust the telephone volume before adjusting the headset volume. To provide the best communication with the least amount of distortion, the amplifier should have a higher setting than the telephone volume control.

Telephone wall-mount kit

For the M3903, M3904, and M3905 telephones, a separate wall-mount bracket kit must be used. This kit contains a one-piece wall-mount plate that attaches the telephone to the wall. The wall-mount kit is available from your local Nortel distributor.

The footstand supplied with the M3901 and M3902 telephones can be reversed to allow wall mount installations. To provide additional support, an optional wall-mount brace kit may be purchased.

The wall-mount kit does not support the Accessory Connection Module (ACM) and its accessory cartridges.

Brandline insert

The M3900 Series Digital Telephones contain a removable insert made to accommodate your company logo. You can order blank Brandline Inserts with your company logo.

The M3903, M3904, and M3905 also support Electronic Brandline. Refer to *Features and Services Fundamentals-Six Books (NN43001-106_B1-B6)* () for information on the Electronic Brandline feature.

Key descriptions

This section provides key description and key configuration information for each model of the M3900 series. This section also shows the physical placement of the keys on each model: M3901, M3902, M3903, M3904, and M3905.

M3901 key descriptions

Table 26 "M3901 key description" (page 124) gives a description of the keys on the M3901. Figure 31 "M3901 key positions" (page 125) shows the physical placement of the keys on the M3901.

Table 26
M3901 key description

Key Number	Description
Key 0	Line (Directory Number) Note: The system administrator can configure Key 0 as a Voice Call (VCC), HotLine (HOT) Key, Single Call Non-ringing (SCN), Multiple Call Ringing (MCR), Multiple Call Non-ringing (MCN), Private Line Ringing (PLR), or Private Line Non-ringing (PLN).
Key 1	Feature or Auto Dial
Key 2	Feature or Auto Dial
Key 3	Feature or Auto Dial
Key 4	Feature or Auto Dial
Key 5	Feature or Auto Dial
Note: The system administrator can configure Keys 1 - 5 with any feature that does not require a display (DAG, DWG, DSP, and RMK).	
Note: Nortel recommends that the M3901 is not configured as an ACD DN.	

Figure 31
M3901 key positions

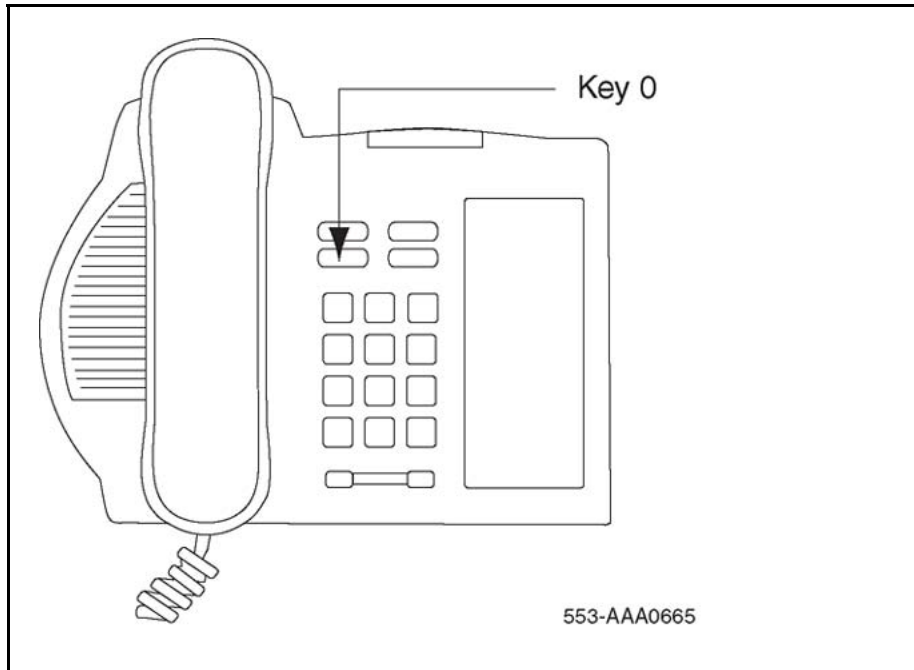

M3902 key descriptions

[Table 27 "M3902 key description" \(page 126\)](#) gives a description of the keys on the M3902. [Figure 32 "M3902 key positions" \(page 127\)](#) shows the physical placement of the keys on the M3902.

Table 27
M3902 key description

Key	Description
Key 0	<p>You must configure Key 0 as the Directory Number line.</p> <p>Note: The system administrator can configure Key 0 as a Voice Call (VCC), HotLine (HOT) Key, Single Call Non-ringing (SCN), Multiple Call Ringing (MCR), Multiple Call Non-ringing (MCN), Private Line Ringing (PLR), or Private Line Non-ringing (PLN).</p>
Key 1	Feature or Auto Dial
Key 2	Feature or Auto Dial
Key 3	Feature or Auto Dial
Key 4	Call Transfer (default) or 3 Party Conference or 6 Party Conference
Key 5	Message Waiting
<p>Note: The M3902 is a single-line set. Only one line can be configured, and this must be on Key 0. Do not configure Keys 1–5 as:</p> <ul style="list-style-type: none"> • Multiple Call Non-ringing • Multiple Call Ringing • Private Line Non-ringing • Private Line Ringing • Single Call Non-ringing • Single Call Ringing <p>Configuring Keys 1–5 as anything other than the allowed features will cause an error message.</p>	

Figure 32
M3902 key positions

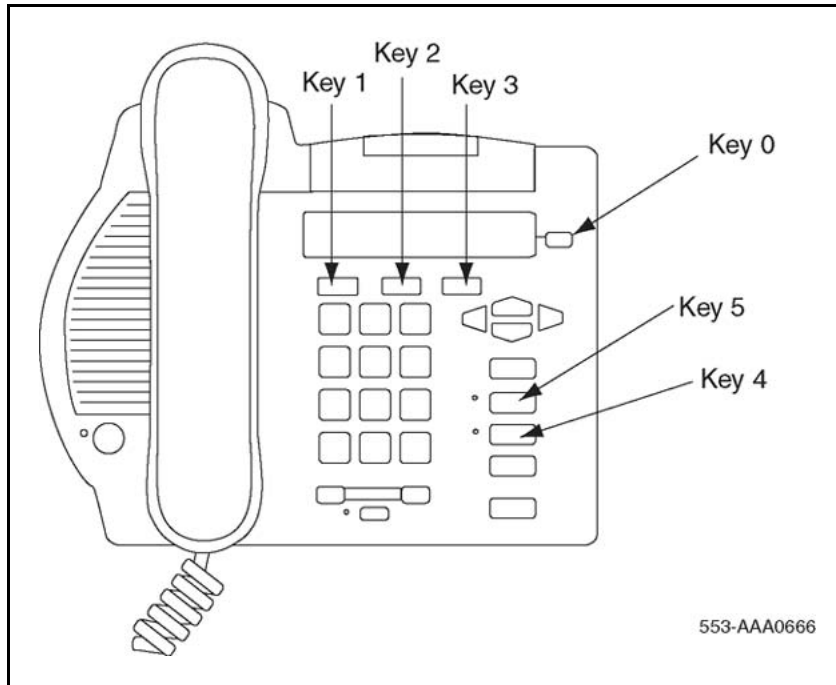

M3903 key descriptions

Table 28 "M3903 key description" (page 127) gives a description of the keys on the M3903. Figure 33 "M3903 key positions" (page 129) shows the physical placement of the keys on the M3903.

Table 28
M3903 key description

Key	Description
Key 0	Primary Directory Number
Key 1	Secondary Directory Number or Feature or Auto Dial
Key 2	Secondary Directory Number or Feature or Auto Dial
Key 3	Secondary Directory Number or Feature or Auto Dial
	<p>Note: Keys 1-3 cannot be configured as the following features:</p> <ul style="list-style-type: none"> • 3 Party Conference • 6 Party Conference • Call Forward • Account Charge • Calling Party Number • Call Park

Table 28
M3903 key description (cont'd.)

	<ul style="list-style-type: none"> • Privacy Release • Ring Again • RPN • Call Transfer <p>Configuring Keys 1-3 as anything other than the allowed features will cause an error message.</p> <p>Note: Keys 1-3 can be configured as Speed Call (Speed Call, System Speed Call, Speed Call Controller and System Speed Call Controller). Nortel recommends that Key 23 be used for Speed Call features.</p>
Key 4-15	Not used at this time
Key 16	Message Waiting (default)
Key 17	Call Transfer (default)
Key 18	6 Party Conference (default) or 3 Party Conference
Key 19	Call Forward (default)
Key 20	Ring Again (default)
Key 21	Call Park (default)
Key 22	Ring Number Pickup
Key 23	<p>Configure as:</p> <ul style="list-style-type: none"> • Speed Call • System Speed Call • Speed Call Controller • System Speed Call Controller (manual configuration—needs speed call list #)
Key 24	Privacy Release (default)
Key 25	Charge Account (default)
Key 26	Calling Party number (default)
Key 27	Callers List (default)
Key 28	Redial List (default)
Keys 29-31	NUL

Figure 33
M3903 key positions

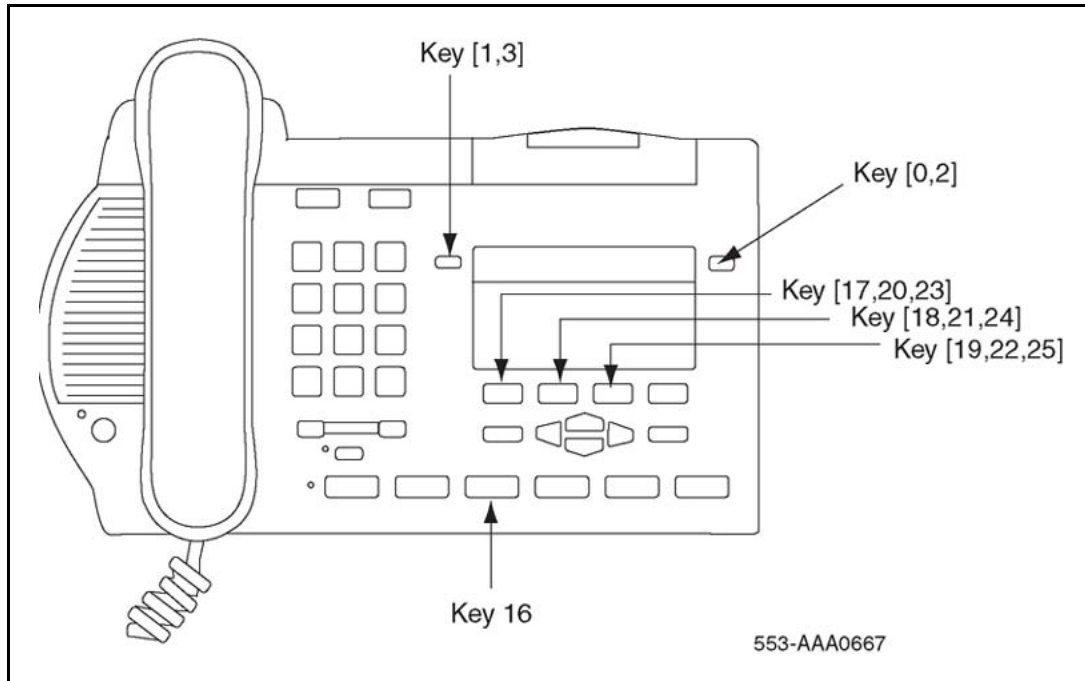

M3904 key descriptions

Table 29 "M3904 key description" (page 129) gives a description of the keys on the M3904. Figure 34 "M3904 key positions" (page 131) shows the physical placement of the keys on the M3904.

Table 29
M3904 key description

Key	Description
Key 0	Primary Directory Number
Key 1-11	<p>Secondary Directory Number or Feature or Auto Dial</p> <p>Note: Keys 1-11 cannot be configured as the following features:</p> <ul style="list-style-type: none"> • Message Waiting • Transfer • 3 Party Conference • 6 Party Conference • Call Forward • Ring Again • Call Park • Ringing Number Pickup

Table 29
M3904 key description (cont'd.)

Key	Description
	<ul style="list-style-type: none"> • Privacy Release • Charge Account • Call Party Number <p>Configuring Keys 1-11 as anything other than the allowed features will cause an error message.</p> <p>Note: Keys 1-11 can be configured as Speed Call (Speed Call, System Speed Call, Speed Call Controller and System Speed Call Controller). Nortel recommends that Key 23 be used for Speed Call features.</p>
Keys 12-15	Blocked
Key 16	Message Waiting is not a default feature for this key
Key 17	Call Transfer (default)
Key 18	6 Party Conference (default) or 3 Party Conference
Key 19	Call Forward (default)
Key 20	Ring Again (default)
Key 21	Call Park (default)
Key 22	Ringing Number Pickup (default)
Key 23	<p>Configure as one of the following:</p> <ul style="list-style-type: none"> • Speed Call • System Speed Call • Speed Call Controller • System Speed Call Controller <p>Note: The above services are not a default feature for this key. These features can be used on any of the programmable keys.</p>
Key 24	Privacy Release (default)
Key 25	Charge Account (default)
Key 26	Calling Party Number (default)
Key 27	Callers List (default)
Key 28	Redial List (default)
Keys 29-31	NUL

Figure 34
M3904 key positions

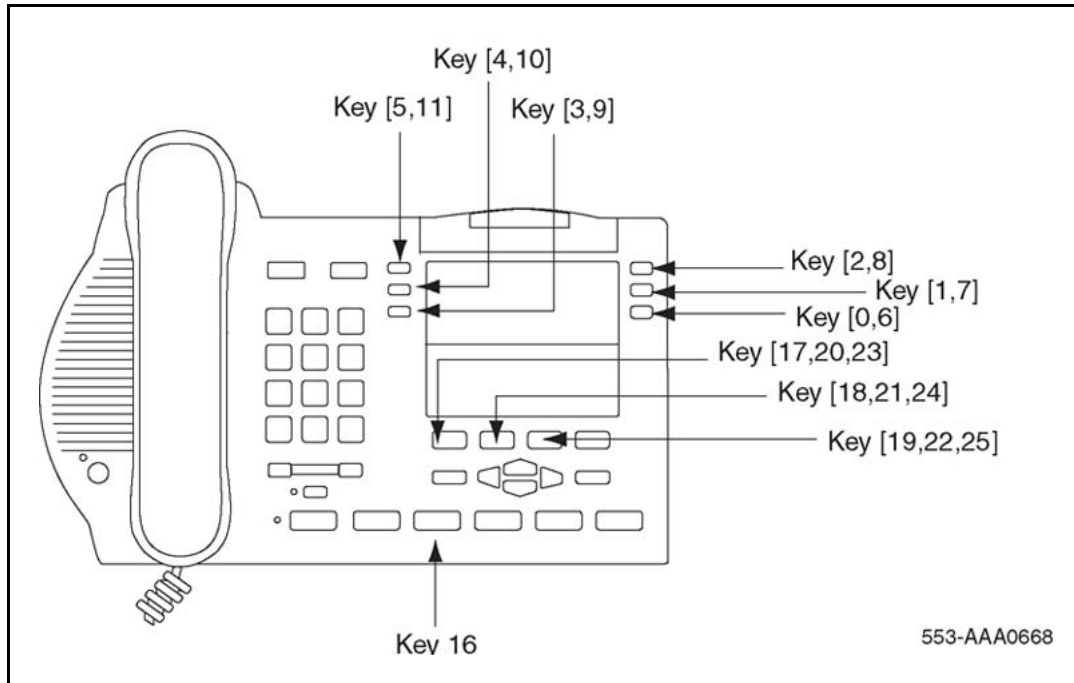

Note: For M3904 and M3905 telephones, One-button feature access keys for the Callers and Redial lists cannot be programmed on DBA or KBA modules.

M3905 key descriptions

Table 30 "M3905 key description" (page 131) gives a description of the keys on the M3905. Figure 35 "M3905 key positions" (page 134) shows the physical placement of the keys on the M3905.

Table 30
M3905 key description

Key	Description
Key 0	<p>Primary ACD Directory Number equivalent to the * In-Calls Key</p> <p>Note 1: The user can edit the label on Key 0 to display desired information.</p> <p>Note 2: The In-Calls fixed key and the Primary DN line key are linked together and both represent Key 0.</p>

Table 30
M3905 key description (cont'd.)

Key	Description
Key 1-4	<p>Secondary Directory Number or Feature or Auto Dial</p> <p>Note: Keys 1-4 cannot be configured as the following features:</p> <ul style="list-style-type: none"> • Message Waiting • Transfer • 3 Party Conference • 6 Party Conference • Call Forward • Ring Again • Call Park • Ringing Number Pickup • Privacy Release • Charge Account • Call Party Number <p>Configuring Keys 1-4 as anything other than the allowed features will cause an error message.</p> <p>Note: Keys 1-4 can be configured as Speed Call (Speed Call, System Speed Call, Speed Call Controller and System Speed Call Controller). Nortel recommends that Key 23 be used for Speed Call features.</p>
Key 5	Feature
Key 6	Feature
Key 7	Options menu key
Key 8-11	<p>Configured as one of the following standard Call Center features:</p> <p>Key 8 = * Make Set Busy</p> <p>Key 9 = * Not Ready (must have CLS = AGN)</p> <p>Key 10 = * Emergency (must have CLS = AGN)</p> <p>Key 11 = * Call Supervisor (must have CLS = AGN)</p> <p>The following features can be configured on any Key 8-11 with the change of the prelabeled key cap:</p>

Table 30
M3905 key description (cont'd.)

Key	Description
	Activity Code entry.Agent Answer Answer Emergency Call Display Queue = DWC (used with supervisor or agent telephones). Observe agent Ring Agent (must have CLS = SPV) Note: Keys 8-11 are prelabeled in the factory; they are marked in this table with an asterisk.
Key 16	Message waiting key or another feature
Key 17	Call Transfer key (default)
Key 18	6 Party Conference (default) or A03 (3 Party Conference)
Key 19	Call Forward (default)
Key 20	Ring Again (default)
Key 21	Call Park (default)
Key 22	Ringing Number Pickup (default)
Key 23	Configured as one of the following speed call services: <ul style="list-style-type: none"> • Speed Call • System Speed Call • Speed Call Controller • System Speed Call Controller
Key 24	Privacy Release (default)
Key 25	Charge Account (default)
Key 26	Calling Party Number (default)
Key 27	Callers List (default)
Key 28	Redial List (default)
Keys 29-31	NUL

Figure 35
M3905 key positions

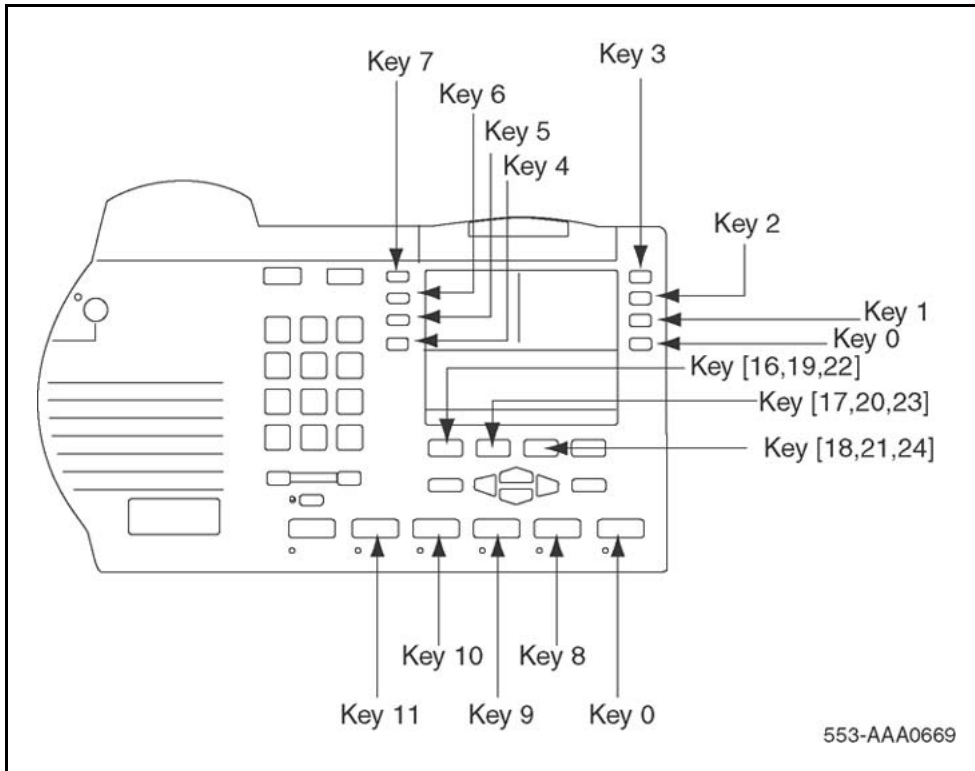

M3900 (single site) Virtual Office

Contents

- [“Introduction” \(page 135\)](#)
- [“Description” \(page 135\)](#)
- [“Operating parameters” \(page 137\)](#)
- [“Feature implementation” \(page 138\)](#)

Introduction

The Virtual Office feature is useful for telecommuters, visitors, and workers who are frequently out of the office. Virtual Office maximizes the use of office space and desktop equipment for Hoteling or Hot-desk applications. The Virtual Office feature provides the capability for the telephone user to login to a designated telephone and be presented with their individual features and services. For example, office space could be set up with host telephones allowing visiting telecommuters to login using the Flexible Feature Code (FFC) and their individual DN. Calls to the user's primary DN are then routed to the Virtual Office host telephone where the Virtual Office worker is logged in.

Description

The Virtual Office feature allows users to log in to a designated M3903 or M3904 Digital Telephone and use their individual telephone configurations at that telephone. The calls to the user's primary DN are routed to the Virtual Office Host Terminal where the Virtual Office worker is logged in.

The Host Terminal is the physical telephone that a user can use to log in as a Virtual Office worker. Both the M3903 and the M3904 can be configured as Host Terminals; however, a Virtual Office worker is required to log in to a Host Terminal that matches their Virtual Office telephone type. For example, when the Virtual Terminal of a Virtual Office worker is configured as an M3904, the login process is blocked if they attempt to login to an M3903 Host Terminal.

The Virtual Terminal is a set of features configured for a user and defined on a phantom loop. There is no permanent physical telephone associated with a Virtual Terminal.

The Virtual Office recognizes all system configuration related to the Virtual Office Worker. The Virtual Office feature operates on a stand-alone Meridian 1 and a CS 1000 system only.

Only one active session per user login ID is allowed at one time in the system. The Virtual Office Worker is identified by their primary DN, which cannot be used as the primary DN for any other telephone, virtual or physical, in the system. Use the Station Control Password (SCPW), configured in LD 11 to validate the login. For further information on configuring the SCPW in LD 11, refer to *Software Input Output Administration (NN43001-611)* ().

Nortel recommends that the Host Terminal have at least internal call and emergency call (911 in North America) capability.

Clearing the Directory Services Password

With Phase III M3900 Series Digital Telephones, the Meridian 1 or CS 1000 system clears the Directory Services password when a Virtual Office worker logs in or logs out of an M3903 or an M3904 Host telephone. The system administrator configures this functionality by defining Class of Service as Erase List Allowed (ELA) in LD 11 for the M3903 or M3904 Virtual telephone. For further information on configuring ELA in LD 11, see LD 11 on [Table 32 "LD 11, Allow or deny the erasing of the Callers and Redial lists for Virtual Terminals"](#) (page 138).

Clearing the Directory Services Password functionality allows multiple Virtual Office worker using the same host telephone to have access to password-protected features if one of the users set the password and does not turn it off when the Virtual Office worker log out.

Clearing the Callers List and Redial List

With Phase III M3900 Series Digital Telephones, the Meridian 1, or the CS 1000 system clears the Callers List and Redial List when a Virtual Office worker logs in or logs out of an M3903 or an M3904 Host telephone. The system administrator configures this functionality by defining Class of Service as Erase List Allowed (ELA) in LD 11 for the M3903 or M3904 Virtual telephone. For further information on configuring ELA in LD 11, see LD 11 on [Table 32 "LD 11, Allow or deny the erasing of the Callers and Redial lists for Virtual Terminals"](#) (page 138).

When the ELA Class of Service is defined, the Callers List and Redial List are automatically cleared when the Virtual Office worker logs in or logs out.

Automatic Logout for Virtual Office

Phase III M3900 Series Digital Telephones introduces Automatic Logout for Virtual Office workers. If a Virtual Office worker, who is already logged in to telephone A, tries to log on to telephone B, the system automatically logs out the Virtual Office worker from telephone A and logs the Virtual Office worker in to Telephone B (provided the correct login password is entered). This feature is activated by the system administrator in LD 15 at the Virtual Office Automatic Logout (VO_ALO) prompt. For further information on configuring the Automatic Logout for Virtual Office in LD 15, see LD 15 on [Table 31 "LD 15, Configure the automatic logout time for Virtual Office terminals"](#) (page 138) .

The system administrator can also define a time at which all Virtual Terminals are automatically logged out. The automatic log out time is configured in LD 15 at the Virtual Office Automatic Logout Time (VO_ALOHR) prompt.

If the telephone is busy at the automatic logout time, (for example, if the Virtual Office worker is using Corporate Directory or Set-to-Set Messaging), the telephone is not logged out until it is in the idle state.

Note: If the user logs in to a Virtual telephone after automatic logout occurs, the telephone does not automatically log out a second time.

Speed Call for Virtual Office

Phase III Meridian Series Digital Telephones support Speed Call (SCU/SCC) and System Speed Call (SSU only) on Virtual Terminal numbers.

Operating parameters

The Virtual Terminal Prime DN cannot be a Primary DN on another terminal. The Virtual Terminal Prime DN (user A) can be the secondary DN of another Virtual Terminal (user B). If both user A and user B are logged in, a call to user A's Primary DN can be answered by user B's Secondary DN.

If Virtual Office user A logs out, user B logs in, and another user calls the Primary DN of user A, the following scenarios can occur:

- If user A has Call Forward configured before logout, the call is forwarded.
- If user A does not have Call Forward configured, but has Default Call Forward (DCFW) configured, the call is forwarded to that DN (the DN can be Call Pilot).
- If neither of the above scenarios apply, the caller receives an overflow tone.

Feature implementation

Table 31

LD 15, Configure the automatic logout time for Virtual Office terminals

Prompt	Response	Description
REQ:	NEW CHG	Add new data Change existing data
TYPE:	FTR	Features and options
CUST		Customer number
	0-99	Range for Large System and CS 1000E system
	0-31	Range for Small System, CS 1000S system, Media Gateway 1000B, and Media Gateway 1000T
...		
VO_ALO	(NO) YES	Disable Virtual Office Automatic Logout (default). Enable Virtual Office Automatic Logout
VO_ALOHR	(0)-23	Virtual Office Automatic Logout time Use the 24-hour clock

Table 32

LD 11, Allow or deny the erasing of the Callers and Redial lists for Virtual Terminals

Prompt	Response	Description
REQ:	NEW CHG	Add new data Change existing data
TYPE:		M3900 series telephone types
	3903V 3904 V	M3903 Virtual Terminal M3904 Virtual Terminal
...		
CLS	(ELD) ELA	Erase Lists (Denied)/Allowed

Table 33

LD 57, Configure the Flexible Feature Codes for the Virtual Office feature

Prompt	Response	Description
REQ	NEW CHG OUT END	Add new data block information Change data block information Remove data block information Exit data block
TYPE	FFC	Flexible Feature Codes data block
...
CODE	VTLN ALL	FFC for logging a Virtual Terminal onto a Host Terminal Every FFC is prompted

Table 33
LD 57, Configure the Flexible Feature Codes for the Virtual Office feature (cont'd.)

Prompt	Response	Description
VTLN	<CR>	No further prompt; returns to "REQ"
	xxxx	Enter Virtual Terminal logging code
CODE	<CR>	Returns to "CODE"
	VTLF	FFC type for logging off a Virtual Terminal
VTLF	ALL	Every FFC is prompted
	<CR>	No further prompt; returns to "REQ"
	xxxx	Enter Virtual Terminal logging off code
	<CR>	Returns to "CODE"
		Note: You cannot move or copy a Virtual Terminal Number.

Table 34
LD 97, Configure a Phantom loop for the Virtual Office feature

Prompt	Response	Description
REQ	CHG	Change the loop configuration
TYPE	SUPL	Superloops
SUPL	Naaa	N = designates the superloop as a phantom loop
		aaa = designates the superloop number
...

Table 35
LD 20, Print Terminal Number Block (TNB) data for Virtual and Host Terminals

Prompt	Response	Description
REQ:	PRT	Print data block for the requested terminal type(s)
TYPE:	LTN	List Terminal Numbers of the requested terminal type(s)
	xxxxx	Enter appropriate telephone model where xxxxx:
	3903V	3903V = M3903 Virtual Terminal
	3904V	3904V = M3904 Virtual Terminal
	3903H	3903H = M3903 Host Terminal
	3904H	3904H = M3904 Host Terminal
	TNB	Note 1: Only M3903 and M3904 Digital Telephones can be configured as a Virtual or Host Terminal.

Table 35
LD 20, Print Terminal Number Block (TNB) data for Virtual and Host Terminals (cont'd.)

Prompt	Response	Description
...	...	Note 2: The Print TNB and List TNB requests always show the logged-off TNB data. In logged-in state, an indication of the logged-in TN ("HOST TN" or "VIRTUAL TN") is added. ...

Table 36
LD 81, Print a list or count of telephones with a specified Class of Service or feature

Prompt	Response	Description
REQ	LST	LST = Print list of telephones
	CNT	CNT = Print count of telephones
CUST		Customer number, where xx designates one customer number, and xx yy designates a range of customer numbers
	0-99	Range for Large System and CS 1000E system
	0-31	Range for Small System, CS 1000S system, Media Gateway 1000B, and Media Gateway 1000T
	<CR>	Print all customers
...
FEAT	aaaa	aaaa = Designates a feature mnemonic
	3900	3900 = prints M3900-type telephones, including Virtual and Host Terminals
	DCFW	DCFW = prints Default Call Forward Virtual Terminals
...

M3900 installation and configuration

Contents

This section contains information on the following topics:

- “Reliability” (page 142)
- “Environmental and safety considerations” (page 142)
 - “Temperature and humidity” (page 142)
 - Figure 27 “M3903 Enhanced Telephone” (page 102)
 - “Line engineering” (page 145)
 - “M3900 set power consumption” (page 145)
- “Installation” (page 146)
 - Procedure 28 “Installing the M3900 Series Digital Telephone” (page 146)
 - “Changing telephone positions” (page 146)
 - “Wall-mounting the telephone” (page 147)
 - “Installing the Accessory Connection Module” (page 148)
 - “Accessory keying” (page 151)
 - “Installing the Analog Terminal Adapter” (page 152)
 - “Installing Personal Directory PC Utility software” (page 153)
 - “Installing the Key-Based Accessory Module” (page 155)
 - “Installing the Single KBA footstand” (page 156)
 - “Installing the Expansion KBA footstand” (page 157)
 - “Installing the Display-Based Accessory Module” (page 157)
 - “Installing the handset option for the M3905 Call Center Telephone” (page 158)
 - “Installing alternate key caps for the M3905” (page 160)
 - “Installing the Full Duplex Handsfree cartridge” (page 161)
- “Configuration” (page 162)
 - “Task summary” (page 162)

Reliability

Reliability is measured by the Mean Time Between Failure (MTBF). The MTBF ratings for M3900 Series Digital Telephones are shown in [Table 37 "M3900 Mean Time Between Failure ratings" \(page 142\)](#).

Table 37
M3900 Mean Time Between Failure ratings

Set	MTBF	Return rate per year
M3901	250 years	0.4%
M3902	200 years	0.5%
M3903	150 years	0.4%
M3904	93 years	0.23%
M3905	100 years	0.25%
Key-Based Accessory module (KBA)	500 years	0.2%
CTI Accessory (CTIA)	50 years	2%
Power supply	30 years	3%

Environmental and safety considerations

Temperature and humidity

Table 38
M3900 operating temperature and humidity requirements

Operating state	
Temperature range	0° to 50°C (32° to 104°F)
Relative humidity	5% to 95% (noncondensing). At temperatures above 34°C (93°F) relative humidity limited to 53 mbar of water vapor pressure.

Table 39
M3900 storage temperature and humidity requirements

Storage	
Temperature range	-50° to 70°C (-58° to 158°F)
Relative humidity	5% to 95% (noncondensing). At temperatures above 34°C (93°F) relative humidity limited to 53 mbar of water vapor pressure.

Safety and Electromagnetic compatibility

The M3900 Series Digital Telephones have been tested and found to comply with Safety and Electromagnetic Compatibility (EMC) standards as shown in [Table 40 "M3900 Safety standards compliance" \(page 143\)](#) and [Table 41 "M3900 Electromagnetic Compatibility standards: Radiated](#)

and conducted" (page 144) and Table 42 "M3900 Electromagnetic Compatibility standards: Immunity" (page 145) on Table 42 "M3900 Electromagnetic Compatibility standards: Immunity" (page 145).

Refer to Product Bulletins or check with your Nortel representative for the latest developments in EMC standards.

Table 40
M3900 Safety standards compliance

Safety	Description
EN 60950 / IEC 60950	Safety of Information Technology Equipment including Electrical Business Equipment (Europe)
UL 60950	Safety of Information Technology Equipment (USA)
CSA 22.2 60950	Safety of Information Technology Equipment (Canada)
AS3260, TS001, TA-1302	Safety (Australia)
JATE	Safety of Telecom Equipment (Japan)

Table 41
M3900 Electromagnetic Compatibility standards: Radiated and conducted

EMC - Radiated and Conducted	Description
FCC CFR 47 Part 15	FCC Rules for Radio Frequency Devices (USA) (See Note "1" (page 144) below.)
CSA C108.8	Radiated Emissions (Canada)
ICES-003	Interference-Causing Equipment Standard: Digital Apparatus (Canada)
EN55022 / CISPR 22	Information technology equipment — Radio disturbance characteristics — Limits and methods of measurement (Europe) (See Notes "2" (page 144) and "3" (page 144) below.)
EN 61000-3-2	Limits for harmonic current emissions (equipment output current \leq 16 A per phase)
EN 61000-3-3	Limitation of voltage fluctuations and flicker in low-voltage supply systems for equipment with rated current \leq 16 A
VCCI	EMC (Japan)
AS/NZS 3548 CISPR 22	Limits and methods of measurement of radio disturbance characteristics of information technology equipment (Australia / New Zealand) (See Notes "2" (page 144) and "3" (page 144) below.)
<p>Note: M3900 Class A telephones comply with Part 15 of the FCC Rules to Class A limits. In a domestic environment, this equipment may cause radio interference, in which case the user may be required to provide adequate protective measures.</p> <p>M3900 Class B telephones comply with Part 15 of the FCC Rules to Class B limits. Operation of Class B equipment is subject the following conditions:</p> <ul style="list-style-type: none"> • The equipment may not cause harmful interference. • The equipment must accept any interference received, including interference that may cause undesired operation. <p>Changes or modifications not expressly approved by Nortel could void the user's authority to operate this equipment.</p> <p>Note 1: The M3903 telephone (NTMN33GA) is CISPR A compliant. The M3903 meets CISPR 22 to Class B limits in the regions of Europe, the Middle East, and Africa.</p> <p>Note 2: The Analog Terminal Adapter (NTMN68xx) is CISPR A compliant. It meets CISPR 22 to Class B limits when used with the M3904 or M3905 telephones.</p>	

Table 42
M3900 Electromagnetic Compatibility standards: Immunity

EMC - Immunity	Description
EN50082-1	Electromagnetic Compatibility - Generic immunity standard Part 1: Residential, commercial and light industry (Europe)
EN 55024	Information technology equipment — Immunity characteristics — Limits and methods of measurement (Europe)
IEC 801-2 (level 4)	Electro Static Discharge (Europe)
IEC 801-3 (level 2)	Radiated Immunity (Europe)
IEC 801-4 (level 3)	Fast Transient/Burst Immunity (Europe)

Line engineering

The M3900 Series Digital Telephones use twisted pair wiring on transmission lines determined by the rules in [“Digital telephones line engineering”](#) (page 223). The maximum acceptable loop length is 1067 m. (3500 ft), assuming 24 AWG (0.5 mm) standard twisted wire with no bridge taps. A 15.5 dB loss at 256 kHz defines the loop length limit. Longer lengths are possible, depending on the wire’s gauge and insulation.



CAUTION

Use only the line cord provided with the telephone. A line cord designed for another telephone can cause damage to the equipment.

M3900 set power consumption

[Table 43 "M3900 set power consumption"](#) (page 145) shows power consumption measurements of the M3900 telephones in various states.

Table 43
M3900 set power consumption

	M3901	M3902	M3903	M3904	M3905
Idle	29.3	37.3	42.5	31.5	15.02
H/F Nominal	N/A	45.7	48.7	37.5	N/A
H/F Maximum	N/A	64.3	59.7	46.4	N/A
DBA Idle	N/A	N/A	N/A	39.29	15.31
DBA H/F Nominal	N/A	N/A	N/A	45.9	N/A

Note: All measurements are in milli-amps.

Table 43
M3900 set power consumption (cont'd.)

	M3901	M3902	M3903	M3904	M3905
DBA H/F	N/A	N/A	N/A	52	N/A
Maximum 2 KBA Idle	N/A	N/A	N/A	33.42	14.98
Note: All measurements are in milli-amps.					

Installation

Use [Procedure 28 “Installing the M3900 Series Digital Telephone”](#) (page 146) to install the M3900 Series Digital Telephone

Procedure 28 Installing the M3900 Series Digital Telephone

Step	Action
1	Complete the wiring and cross-connections (loop power). <p>Note: The M3901, M3902, and M3903 are polarity sensitive. The Tip and Ring connections from the telephones to the Digital Line Cards (DLC) must be connected directly. If the Tip and Ring signals are crossed on an M3901, M3902, or M3903, the telephone will not function.</p>
2	Connect the telephone to the connecting block.
3	Place the telephone upright on the desk in the normal operating position.
4	Supply the user with a quick reference guide.
--End--	



CAUTION

Before handling internal telephone components, you must discharge static electricity from your hands and tools by touching any grounded metal surface or conductor.

Changing telephone positions

The M3903, M3904 and M3905 Digital Telephones have several different height selections for the desktop positions.

Use [Procedure 29 “Changing the telephone position”](#) (page 147) to change the telephone position.

Procedure 29
Changing the telephone position

Step	Action
1	Press the tilt handle located at the top back side of the telephone.
2	With the tilt handle pressed in, raise or lower the telephone to the desired angle or height.
3	Release the tilt handle to lock the telephone in the desired position.

Note: The M3903 and M3904 can be wall-mounted using the optional wall-mount bracket.

--End--

The M3901 and M3902 Digital Telephones have three different angled height desktop positions.

Use [Procedure 30 "Changing the telephone angle" \(page 147\)](#) to change the telephone angle.

Procedure 30
Changing the telephone angle

Step	Action
1	Move the top of the footstand away from the telephone base (it has a snap connection).
2	Place the footstand in the desired position and snap the top of the footstand back into place.

--End--

Wall-mounting the telephone

For the M3903, M3904, and M3905 Digital Telephones, a separate wall-mount bracket kit must be used to wall-mount the telephone. The telephone wall-mount bracket kit contains a one-piece wall-mount plate to attach the telephone to the wall. For the M3901 and M3902 telephones,

the supplied footstand can be reversed to allow wall-mount installation. An optional wall-mount brace kit may be purchased for the M3901 and M3902 to provide additional support.

Note: The Key-Based and Display-Based Accessory modules cannot be wall-mounted.

Use [Procedure 31 “Wall-mounting the telephone” \(page 148\)](#) to wall-mount the telephone.

**Procedure 31
Wall-mounting the telephone**

Step	Action
1	Place the wall-mount bracket against the wall and mark the spot to insert the screws. Note: M3901 and M3902 have built-in wall-mount brackets.
2	Screw the five screws in and leave about 3 1/2 mm (1/8 inch) between the head of the screw and the wall.
3	Remove the footstand from the telephone by sliding the footstand down (using the plastic hinges) about 7 mm (1/4 inch).
4	Swing the footstand away from the telephone base and remove from the telephone.
5	Attach the wall-mount bracket onto the back of the telephone by placing the telephone at the top edge of the wall-mount bracket and sliding the telephone into place.
6	Mount the wall-mount bracket, attached to the telephone onto the screws located on the wall.

--End--

Installing the Accessory Connection Module

Use the [Procedure 32 “Installing the ACM” \(page 148\)](#) to install the Accessory Connection Module (ACM).

**Procedure 32
Installing the ACM**

Step	Action
1	Disconnect the line cord from the telephone base before installing the ACM.

- 2 Slide the footstand down (using the plastic hinges) about 7 mm (1/4 in.) and swing the footstand away from the telephone base.
- 3 Snap the ACM into the rectangular opening on the back of the telephone.
- 4 Connect the ACM cable to the back of the telephone.
- 5 Put the ACM attached ribbon cable into the track running down the back of the telephone base.
- 6 Put the hard plastic cable cover over the ACM ribbon cable.
- 7 Snap the ACM plastic cable cover into place.
- 8 Place the footstand on the hinges.
- 9 Swing the footstand back into place.
- 10 Snap the footstand into a non-movable position.
- 11 Reconnect the line cord to the telephone base.
- 12 Return the telephone to an upright position.

--End--

There is a cutout on the base of the footstand which displays the ACM connector ports. When ready to attach an accessory, insert the appropriate cartridge into the port slot. There is one accessory port available on the M3902. There are two accessory ports available on the M3903, M3904 and M3905.

Note 1: A wall transformer is required to power any accessory cartridges. The transformer does not come with the ACM unit. Contact your Nortel local distributor to order this ACM compatible wall transformer. Refer to the procedure ["Installing the wall transformer"](#) (page 150).

Note 2: Refer to the manufacturer's documentation for complete installation and configuration instructions for your external analog device (FAX machine, modem, or 500/2500 telephone).

Note 3: The accessories you attach to the telephone must be compatible. [Table 25 "Accessory compatibilities"](#) (page 116) shows the compatibility of the available options.

[Figure 36 "ACM module"](#) (page 150) shows the installation of the ACM into the telephone footstand.

Figure 36
ACM module

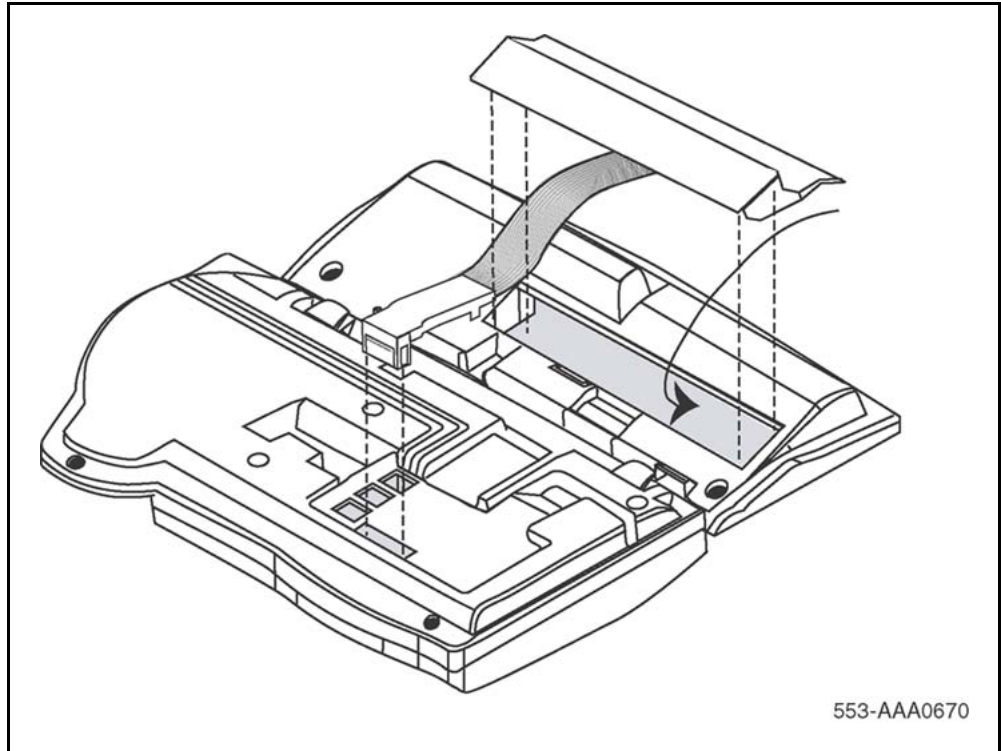

553-AAA0670

Installing the wall transformer

Use [Procedure 33 "Installing the wall transformer"](#) (page 150) to install the wall transformer.

Procedure 33
Installing the wall transformer

Step	Action
1	Remove the line cord from the telephone jack.
2	Insert the transformer adapter plug into the telephone wall jack.
3	Insert the line cord into the wall transformer adapter jack.

--End--

[Figure 37 "Wall transformer connections"](#) (page 151) shows the connections for the wall transformer.

Figure 37
Wall transformer connections

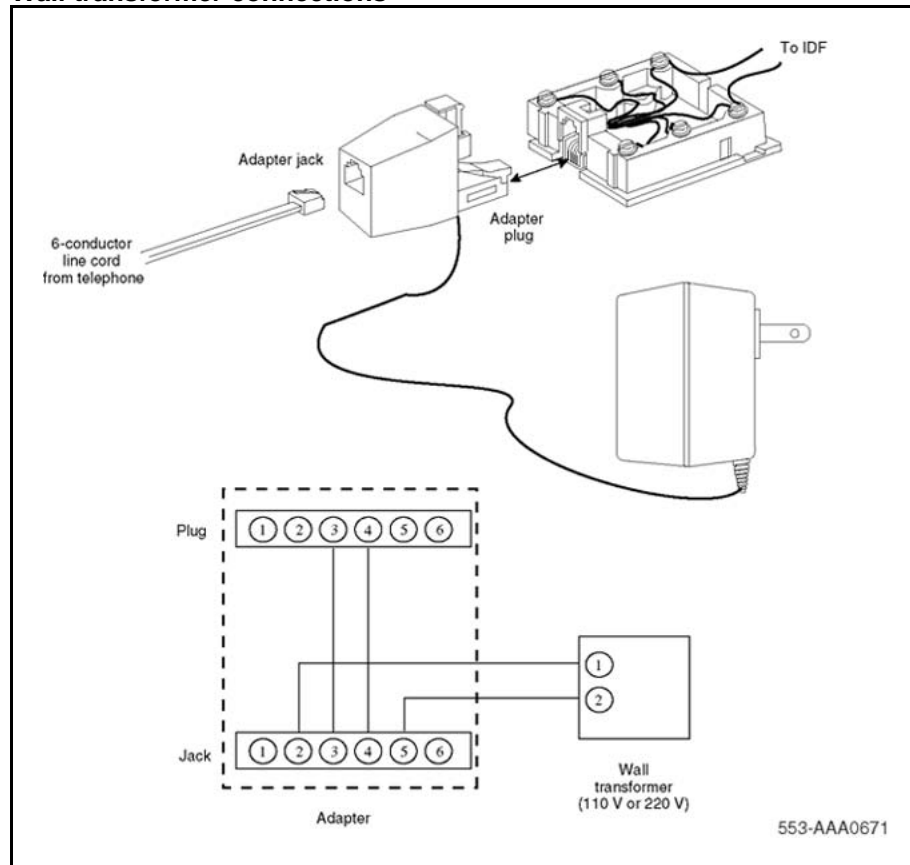

Accessory keying

On the M3903, M3904, and M3905 Digital Telephones there are two accessory ports on the back of the telephone footstand. On the M3902, there is a single accessory port on the back of the footstand. Each port can support one cartridge accessory.

You cannot use two accessories that require the same port type at the same time. For example, you cannot use two accessories that require a serial port connection at the same time.

The shape and size of the plug in the accessory cartridge prevents the user from accidentally connecting incompatible accessories. To check the compatibility of accessories, refer to [Table 25 "Accessory compatibilities" \(page 116\)](#), which shows the optional accessories and their compatibility.

Installing the Analog Terminal Adapter

The Analog Terminal Adapter (ATA) allows an off-the-shelf analog device (FAX, modem, or analog [500/2500-type] telephone) to work simultaneously with your M3902, M3903, M3904, or M3905 Digital Telephone. The ATA is not supported on the M3901 telephone.

Install the Accessory Connection Module (ACM) into your M3900 Series Digital Telephone. Refer to [“Installing the Accessory Connection Module” \(page 148\)](#) before you install your ATA. The ACM provides connection capabilities between the M3902, M3903, M3904, and M3905 telephones and the ATA.

Use the [Procedure 34 “Installing the ATA” \(page 152\)](#) to install the ATA.

Procedure 34 Installing the ATA

Step	Action
1	Disconnect the line cord from the telephone before installing the ATA.
2	Insert the ATA accessory cartridge into the ACM. The latch should be at the top.
3	Connect the commercial device you have selected to use, either your FAX machine, modem, or analog (500/2500-type) telephone, to the connection on your ATA cartridge interface.
4	Plug the transformer into the electrical outlet (use only the transformer designed for your ACM accessories).
5	Connect the Adapter plug, attached to your transformer, into the telephone wall jack. The wall transformer Adapter plug attaches between the telephone line cord and the telephone wall jack.
6	Connect the line cord to the Adapter jack attached to the wall transformer.
7	Reconnect the line cord back to your telephone base.

Note: The ATA supports connections to Plain Old Telephone Service (POTS) only. ATA does not support features such as Message Waiting, Switchhook Flash/Link, Transfer, Conference, and CLASS type services.

--End--

A red LED status light located on the ATA indicates the status of the ATA.

- **Flashing red** indicates that the ATA is operating normally. For more troubleshooting guidelines, refer to the user documentation that came with your analog device.
- **Solid red** indicates that the ATA is not operating normally. Contact your system administrator.
- **Red light off** indicates that there is no power going to the ATA or the unit is not operating correctly. Check the power connections to the ATA. If problems continue, contact your system administrator.

Flexible voice and data capabilities allow you to have continuous use of both the M3900 Series Digital Telephone and the attached analog device. Your system administrator configures the flexible voice and data capabilities for your telephone on the system equipment. Contact your system administrator for more information about flexible voice and data capability.

When there is a power failure to the ATA, the Analog Device does not store or keep information (for example, outgoing FAX from your FAX machine). You must send the information again when power returns.

[Table 44 "ATA configuration" \(page 153\)](#) shows prompts and responses when configuring the ATA.

Table 44
ATA configuration

Prompt	Response	Description
REQ	NEW	Input new data
	CHG	Change current data.
CLS	aaaa	Class of Service options, where aaaa: = (FLXD) - Flexible voice/data denied = FLXA - Flexible voice/data allowed, required if ATA equipped. = (VCE) - Voice terminal, required if ATA equipped. = DTA - Data terminal. Note: If ATA is installed, CLS must be FLXA, VCE.
KEY	0 SCR xxxx	Single Call Ringing, where xxxx = the DN for ATA

Installing Personal Directory PC Utility software

The Personal Directory PC Utility provides a faster, easier way to create or modify a personal directory. You can enter names and numbers into a Personal Directory file on your Personal Computer (PC). You can download the PC file directly to the M3904 or M3905 telephone. You can upload a directory from the M3904 to a PC to modify the M3904 directory.

Use Procedure 35 “Installing the Personal Directory PC Utility software” (page 154) to install the Personal Directory PC Utility software.

Procedure 35
Installing the Personal Directory PC Utility software

Step	Action
1	Close all open applications before installing the Personal Directory PC Utility.
2	Insert the Personal Directory PC Utility disk into your floppy disk drive.
3	Click on Start .
4	Select Run .
5	Enter a:\setup (assuming that drive "a" is your floppy disk drive).
6	Click on OK . The Nortel logo screen appears while the installation utility loads.
7	The Welcome screen appears. Click Next to continue installation.
8	If you agree to the terms of the Software License Agreement, click Yes .
9	Continue to click Next until the installation is complete.
10	When asked to, remove the disk from your floppy disk drive.
11	Click Finish .

Note: You must restart your PC to access the Personal Directory PC Utility.

12 To select a port for the Personal Directory PC Utility; click **Phone**. Click **Set** port. The pull-down menu shows available PC ports:

- Com1
- Com2

--End--

Note: The program selects the same port each time until you change it.

Installing the Key-Based Accessory Module

The Key-Based Accessory (KBA) module provides 22 additional line/feature keys for the M3904 and M3905 Digital Telephones. You can add up to two KBAs, providing a total of 75 line/feature keys.

Use [Procedure 36 "Installing the KBA" \(page 155\)](#) to install the KBA.

Procedure 36 Installing the KBA

Step	Action
1	While depressing the telephone tilt handle, pull the telephone away from the footstand until it clears the final stop. Gently pull the footstand off the clips. <p style="margin-left: 40px;">Note: If an ACM is installed, unplug the ACM and remove it from the footstand. Install the ACM in the Single KBA Footstand Assembly.</p>
2	Place the telephone and the KBA face down on a padded, level surface, and align them.
3	Plug the cable from the KBA into the 10-pin connection port on the telephone. See Figure 38 "KBA Installation" (page 155) .

Figure 38
KBA Installation

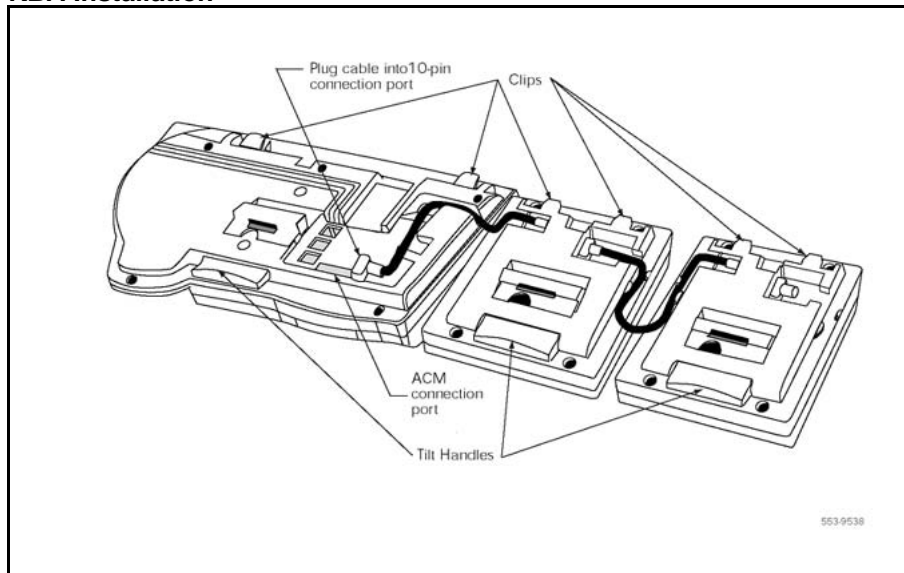

- 4 Thread the cable through the opening in the side of the telephone.
- 5 Insert the clips on the telephone into the hinges on the footstand; then press on the front of the footstand until it snaps into place.

- 6 Install the Single KBA Footstand Assembly. See [Figure 39 "KBA Footstand Assembly"](#) (page 156).

Figure 39
KBA Footstand Assembly

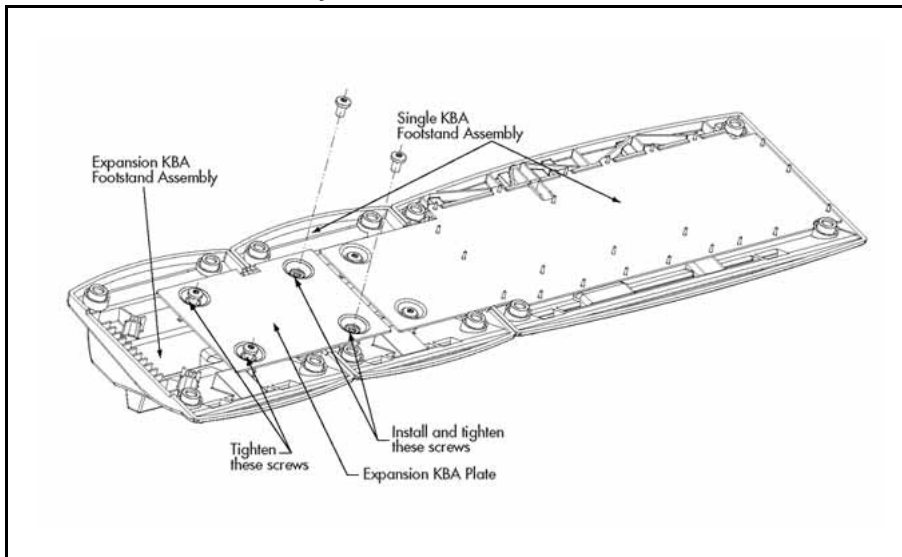

- 7 To add a second KBA:
- a Place the telephone and the two modules face down on a non-abrasive surface.
 - b Plug the cable from the second module into the 10-pin connection port on the first module.
 - c Thread the cable through the routing clips on both modules.
 - d Install the Expansion KBA footstand.

--End--

Installing the Single KBA footstand

Use [Procedure 37 "Installing the Single KBA footstand"](#) (page 156) to install the Single KBA footstand.

Procedure 37 Installing the Single KBA footstand

Step	Action
1	Insert the clips on both the telephone and the KBA into the hinges on the footstand assembly, and press on the front of the footstand until they snap into place.
2	While squeezing both the telephone and the KBA tilt handles, swing the footstand into the desired position.

-
- 3 Turn the completed assembly upright.
-

--End--

Installing the Expansion KBA footstand

Use [Procedure 38 "Installing the Expansion KBA footstand" \(page 157\)](#) to install the Expansion KBA footstand.

Procedure 38 Installing the Expansion KBA footstand

Step	Action
1	Place the Single KBA footstand and the Expansion KBA footstand face down on a flat surface.
2	Align the Expansion KBA footstand with the Single KBA footstand and slide them together.
3	Insert two screws through the Expansion KBA plate into the Single KBA footstand.
4	Tighten all four screws, ensuring that the two footstand assemblies are properly aligned.
5	Insert the clips on the telephone and the KBAs into the hinges on the combined Single Expansion KBA footstand Assembly, and while squeezing the Module tilt handles, swing the footstand into the desired position.
6	Turn the completed assembly upright.

--End--

Installing the Display-Based Accessory Module

The Display-Based Accessory Module (DBA) gives you three layers of eight programmable line/feature (soft-labeled) keys, for a total of 24 (keys 32 through 55).

The **Page** button allows you to scroll to each key layer. The soft-labeled field is 10 characters in length. You can customize the DBA labels using the program mode and the dial pad keys.

Use [Procedure 39 "Installing the DBA" \(page 158\)](#) to install the DBA.

Procedure 39
Installing the DBA

Step	Action
1	While depressing the telephone tilt handle, pull the telephone away from the footstand until it clears the final stop. Gently pull the footstand off the clips.
2	Place the telephone and the DBA face down on a padded level surface, and align them.
3	Lower the DBA into place, and insert the 10-pin plug on the Module into the 10-pin slot on the telephone. Push in gently until the retaining tabs snap into place.
4	Insert the clips on the telephone into the hinges on the footstand, then press on the front of the footstand until it snaps into place.
5	While depressing the telephone tilt handle, swing the footstand into the desired position, then release the handle.
6	Carefully turn the new assembly upright.

--End--

Installing the handset option for the M3905 Call Center Telephone

A handset does not accompany the M3905 Call Center Telephone. The Handset Kit is a hardware option for the M3905 Call Center Telephone, and includes a handset, cord, and add-on handset cradle. The handset can be added to the M3905 by removing the front plate of the telephone.

Note: Nortel recommends that a systems administrator or technician complete this installation.

Table 45
Removal of the Hook Switch Cover

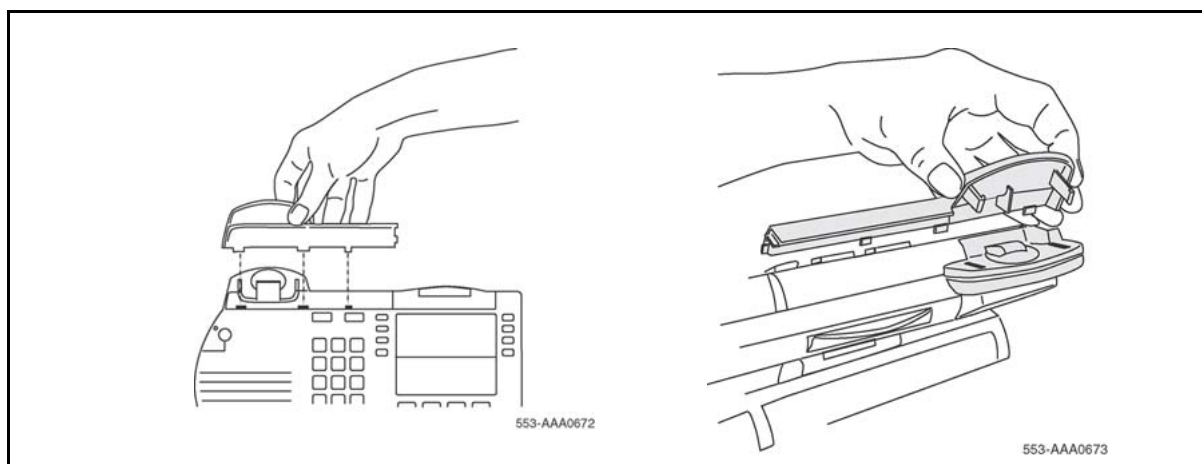

Front view

Rear view

There are five tabs and two hidden snaps on the HookSwitch cover. There are two tabs along the right and three along the bottom edge (Front view). To remove the cover, the hidden snaps must be released (Rear view).

Use [Procedure 40 “Removing the HookSwitch cover” \(page 159\)](#) to remove the HookSwitch cover.

Procedure 40
Removing the HookSwitch cover

Step	Action
1	Ease the cover to the left and pull on the left side to release the left snap.
2	While holding the left snap out, ease the cover to the right and pull on the right side to release the right snap.
3	Carefully maneuver the cover out from the three bottom slots and rotate the cover to release the two side tabs.
--End--	

Use [Procedure 41 “Installing the cradle” \(page 159\)](#) to install the cradle.

Procedure 41
Installing the cradle

Step	Action
1	Hold the cradle in the same position as when you removed the Hook Switch Cover; move the cradle to the right to place the tab into the slot.
2	Ease the other tabs on the bottom edge of the cradle into the slots.

Figure 40
Installation of the cradle

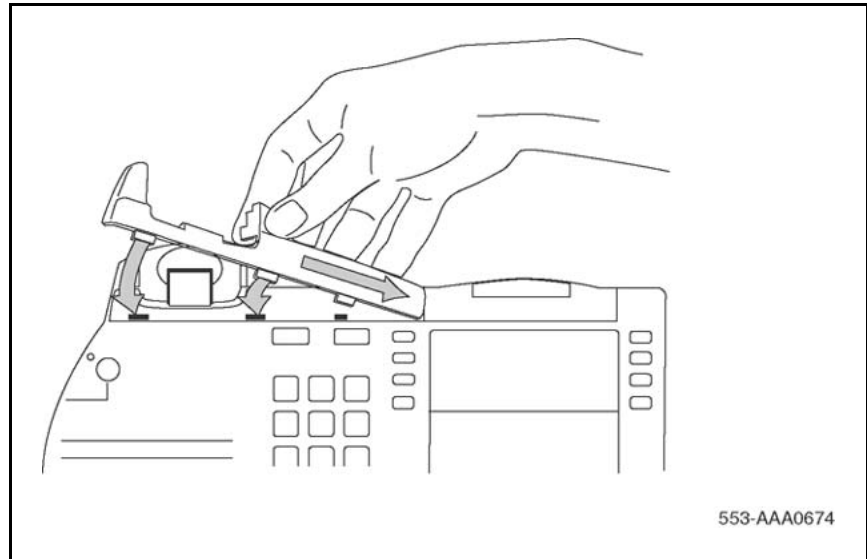

- 3** When all tabs are in the proper position, secure the cradle into place by pushing straight downward.

--End--

Installing alternate key caps for the M3905

Use the Key Extractor Tool with the M3905 Call Center Telephone to remove the programmable keys and replace them with alternate keys customizing your telephone to fit your need.

Figure 41
Install the alternate key caps

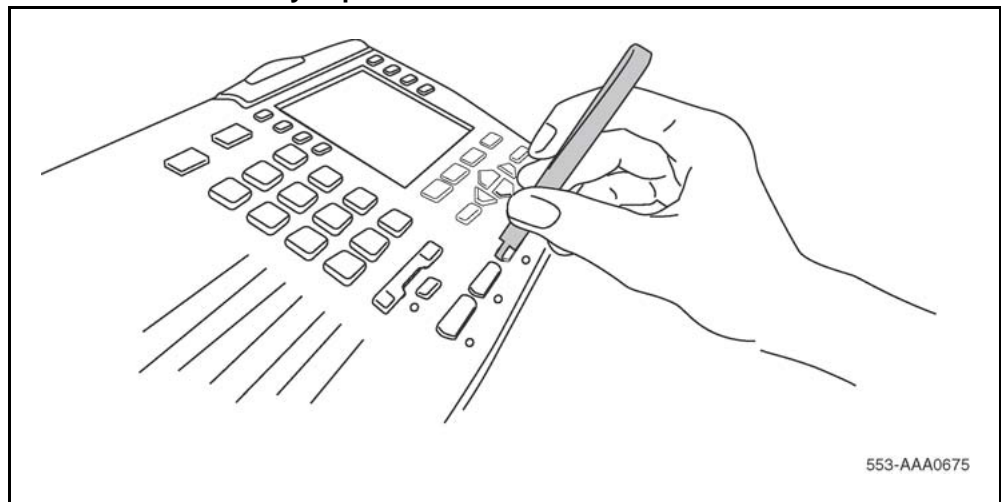

As shown in “[Terminal options](#)” (page 383), place the tips of the tool into the slots at the right and left of the key, grip tightly and pull straight upward. Do not rock or twist the key during removal or insertion, as this may damage the key seat and impair the functionality of the set.

Use [Procedure 42 “Installing the key caps”](#) (page 161) to install the key caps.

Procedure 42
Installing the key caps

Step	Action
1	Fit the two small elastomer posts into two slots on the undersides of the keys and firmly press downward.
2	The key releases immediately after pressure is applied.
	Note: If the key does not release, remove it. Attempt the installation again making sure that the posts and the slots are properly aligned.
--End--	

Installing the Full Duplex Handsfree cartridge

Use [Procedure 43 “Installing the Full Duplex Handsfree cartridge”](#) (page 161) to install the Full Duplex Handsfree cartridge.

Procedure 43
Installing the Full Duplex Handsfree cartridge

Step	Action
1	Check the label on the back of your set to make sure that it is an M3904 Phase III set (NTMN34GA). If your set is an NTMN34GA, go to Step 2 . If your set is not an NTMN34GA, it is not FDHF-compatible. Please contact your system administrator to obtain the correct set.
2	Install the Accessory Connection Module (ACM). For information on how to install the ACM, refer to “ Installing the Accessory Connection Module ” (page 148).
3	Insert the FDHF cartridge into one of the ACM ports.
4	Plug the wall transformer into the electrical outlet.

- 5 Disconnect the telephone line cord from the telephone wall jack. See [Figure 37 "Wall transformer connections" \(page 151\)](#).
- 6 Connect the wall transformer adapter plug into the telephone wall jack. See [Figure 37 "Wall transformer connections" \(page 151\)](#).
- 7 Connect the telephone line cord to the wall transformer adapter jack. See [Figure 37 "Wall transformer connections" \(page 151\)](#).
- 8 Verify that the FDHF cartridge is working properly. The FDHF cartridge is working properly when the red LED on the FDHF cartridge is flashing and when there are 18 segments on the volume bar.

--End--

Configuration

Task summary

The following is a summary of the tasks in this section:

1. [Table 46 "LD 11, Configure the M3900 Series Digital Telephone" \(page 163\)](#)
2. [Table 47 "LD 15, Assign a default language and customize Set-to-Set Messages" \(page 166\)](#)
3. [Table 48 "LD 11, Configure Callers List and Redial List keys" \(page 167\)](#)
4. [Table 49 "LD 11, Configure the default language for M3900 telephones" \(page 168\)](#)
5. [Table 50 "LD 11, Configure the Server-based Applications \(Corporate Directory and Set-to-Set Messaging\)" \(page 169\)](#)
6. [Table 51 "LD 32, Clear or reset a Personal Directory Password for M3900 telephones." \(page 170\)](#)
7. [Table 53 "LD 22, Print M3900 peripheral software versions" \(page 171\)](#)

Note: The firmware versions for each M3900 telephone type will be printed along with the versions of any other downloadable peripheral software.

8. [Table 54 "LD 97, Configure parameters for System-wide Flash Download" \(page 171\)](#)

- 9. [Table 55 "LD 11, Configure Full Duplex Handsfree Class of Service" \(page 173\)](#)
- 10. [Table 56 "LD 32, Flash Download commands" \(page 174\)](#)

Note: For more information, refer to *Software Input Output Administration (NN43001-611) ()* , *Software Input Output Reference - Maintenance (NN43001-711) ()* , and *Software Input Output Reference - System Messages (NN43001-712) ()* .

Table 46
LD 11, Configure the M3900 Series Digital Telephone

Prompt	Response	Description
REQ:	NEW	New data
	CHG	Change current data
TYPE:	x..x	Type of telephone
		3901 = M3901 3902 = M3902 3903 = M3903 3904 = M3904 3905 = M3905 3903H = M3903 Host Terminal 3904H = M3904 Host Terminal 3903V = M3903 Virtual Terminal 3904V = M3904 Virtual Terminal
		Note 1: The M3903, M3904, and 3905 Digital Telephones only support the Host Terminal and the Virtual Terminal feature. Note 2: If the M3901, M3902 or M3905 are configured as a Virtual Terminal, the error message SCH0099 is output. Note 3: M3903, M3904, and M3905 Digital Telephones support Corporate Directory and Set-to-Set Messaging.
TN		Terminal number
	l s c u	Format for Large System and CS 1000E system, where l = loop, s = shelf, c = card, u = unit.
		If confirmed as 3903V or 3904V, the loop must be a phantom. If confirmed as 3903H or 3904H, the loop must NOT be a phantom.

Table 46
LD 11, Configure the M3900 Series Digital Telephone (cont'd.)

Prompt	Response	Description
	c u	Format for Small System, CS 1000S system, Media Gateway 1000B, and Media Gateway 1000T, where c = card and u = unit. Input only the card and unit address. If confirmed as 3903V or 3904V, the card must be a phantom (card slots 61-80). If the telephone has an Analog Terminal Adapter (ATA), then use the voice Terminal Numbers 16-31.
...
DES	d...d	Designator d...d = represents an Office Data Administration System (ODAS) Station Designator of 1-6 alphanumeric characters
...
CUST	xx	Customer number as defined in LD 15
...
KBA	(0)-2	Key-based Accessory module (configuration prompt KBA) The KBA prompt appears when the set type is M3904 or M3905. 0 = allows configuration of up to and including key number 31 1 = allows configuration of up to and including key number 53 2 = allows configuration of up to and including key number 75
DBA	(0)-1	Display-based Accessory module (configuration prompt DBA) If KBA is a non-zero value, then DBA is not prompted. If KBA is a zero value or if the carriage return is pressed, then the DBA prompt appears. 0 = allows configuration of up to and including key number 31 1 = allows configuration of up to and including key number 55
FDN	xxx...x	Flexible CFNA (Call Forward No Answer) DN
...
SCPW	xxx...x	Station Control Password

Table 46
LD 11, Configure the M3900 Series Digital Telephone (cont'd.)

Prompt	Response	Description
...
CLS	aaaa	<p>Class of Service options where aaaa:</p> <ul style="list-style-type: none"> = (GRLD) Group Listening Denied, (M3902, M3903, M3904) = GRLA Group Listening Allowed, (M3902, M3903, M3904) = (HFD) Handsfree Denied, M3902, M3903, M3904) = HFA Handsfree Allowed (M3902, M3903, M3904) = ADD Automatic Digit Display, default for M3902, M3903, M3904, M3905 = (VCE) Voice Terminal, required if ATA equipped = DTA Data Terminal = (FLXD) Flexible voice/data denied = FLXA Flexible voice/data allowed, required if ATA equipped = (STSD) Set-to-Set Messaging Denied, (M3903, M3904, and M3905) = STSA Set-to-Set messaging Allowed, (M3903, M3904, and M3905) = (CRPD) Corporate Directory Denied, (M3903, M3904, and M3905) = CRPA Corporate Directory Allowed. (M3903, M3904, and M3905) <p>Note 1: If ATA is equipped, CLS = FLXA, VCE required</p> <p>Note 2: M3903 and M3904 must have HFA Class of Service for the Headset to operate.</p>
...
DCFW	z..z	<p>Default Call Forward DN</p> <p>DN where calls are forwarded (the target DN) The maximum length of the DCFW is 31</p> <p>x = remove the DCFW DN</p> <p>Note: The DCFW prompt appears only for Virtual Terminals (3903V, 3904V).</p>
	x <CR>	

Table 46
LD 11, Configure the M3900 Series Digital Telephone (cont'd.)

Prompt	Response	Description
KEY	xx aaa yyyy zzz	<p>Telephone function key assignments where:</p> <p>xx = key number</p> <p>aaa = key name or function</p> <p>yyyy, zzz = additional information required</p> <p>Refer to the Key description table for each M3900 telephone:</p> <p>Table 26 "M3901 key description" (page 124)</p> <p>Table 27 "M3902 key description" (page 126)</p> <p>"M3903 key description" on Table 28 "M3903 key description" (page 127)</p> <p>"M3904 key description" on Procedure 70 "Installing and removing the M2006/M2008 Power Supply Board on NTZK sets" (page 317)</p> <p>"M3905 key description" on Table 30 "M3905 key description" (page 131)</p> <p>MTAD (CS 1000 and Meridian 1 Time and Date) - the system puts a block on the time/date key on all the M3900 Series Meridian Digital Telephones</p> <p>Note 1: VTN primary DN cannot be a primary DN for any other TN, and the VTN must be defined as a MARP TN.</p> <p>Note 2: The DN of a Virtual Terminal cannot be defined on a Host Terminal, and the Host Terminal DN cannot be defined on a Virtual Terminal.</p>
...

Table 47
LD 15, Assign a default language and customize Set-to-Set Messages

Prompt	Response	Description
REQ:	NEW CHG	Add new data Change existing data
TYPE:	FTR	Features and options

Table 47
LD 15, Assign a default language and customize Set-to-Set Messages (cont'd.)

Prompt	Response	Description
CUST		Customer number
	0-99	Range for Large System and CS 1000E system
	0-31	Range for Small System, CS 1000S system, Media Gateway 1000B, and Media Gateway 1000T
...		
DFLT_LANGUAGE		M3900 default language.
	(ENG)	English (default)
	FRE	French
	GER	German
	DUT	Dutch
	SPA	Spanish
	ITA	Italian
	NOR	Norwegian
	SWE	Swedish
	DAN	Danish
	POR	Portuguese
	FIN	Finnish
	POL	Polish
	CZE	Czech
	HUN	Hungarian
	JAP	Japanese
	RUS	Russian
STS_MSG	(NO) YES	Modify Set-to-Set messages
MSG 01	<CR>	Keeps current message
	<text string>	Input the new message to be displayed (up to 24 characters)
...		
MSG 10	<CR>	Keeps current message
	<text string>	Input the new message to be displayed (up to 24 characters)

Table 48
LD 11, Configure Callers List and Redial List keys

Prompt	Response	Description
REQ:	NEW	Add new data
	CHG	Change existing data
TYPE:		M3900 series telephone types

Table 48
LD 11, Configure Callers List and Redial List keys (cont'd.)

Prompt	Response	Description
	3903H 3904H 3903V 3904V 3905	M3903 Host set M3904 Host set M3903 Virtual set M3904 Virtual set M3905 set
...		
KEY	27 CLT	Configure Callers List key on a Context-sensitive soft key. CLT and NUL are the only options for KEY 27.
KEY	28 RLT	Configure the Redial List key on a Context-sensitive soft key. RLT and NUL are the only options for KEY 28.
KEY	XX CLT	Configure the Callers List key on an available programmable feature key.
KEY	XX RLT	Configure the Redial List key on an available programmable feature key.

Table 49
LD 11, Configure the default language for M3900 telephones

Prompt	Response	Description
REQ:	NEW CHG	Add new data Change existing data
TYPE:		M3900 series telephone types
	3902 3903H 3904H 3903V 3904V 3905	M3902 set M3903 Host set M3904 Host set M3903 Virtual set M3904 Virtual set M3905 set
...		
MLNG		M3900 language selection The default is the language selection chosen for the customer in LD 15. Note: The user can change the language defined at the MLNG prompt from their set.

Table 49
LD 11, Configure the default language for M3900 telephones (cont'd.)

Prompt	Response	Description
	ENG	English
	FRE	French
	GER	German
	HEB	Hebrew
	DUT	Dutch
	SPA	Spanish
	ITA	Italian
	NOR	Norwegian
	SWE	Swedish
	DAN	Danish
	POR	Portuguese
	FIN	Finnish
	POL	Polish
	CZE	Czech
	HUN	Hungarian
	JAP	Japanese
	RUS	Russian
	LAT	Latvian
	TURK	Turkish

Table 50
LD 11, Configure the Server-based Applications (Corporate Directory and Set-to-Set Messaging)

Prompt	Response	Description
REQ:	NEW	New data
	CHG	Change current data
TYPE:	3903 3904 3905	M3900 set types that support the Corporate Directory and the Set-to-Set Messaging.
...
CLS	aaaa	<p>Class of Service options where aaaa:</p> <p>= ADD - Automatic Digit Display, default for M3903, M3904, and M3905</p> <p>= (VCE), DTA - Voice Terminal, Data Terminal</p> <p>= (FLXD) - Flexible voice/data Denied</p> <p>= FLXA - Flexible voice/data Allowed</p> <p>Note: Class of Service must be VCE, FLXA if telephone is equipped with the optional Analog Terminal Adapter.</p>

Table 50
LD 11, Configure the Server-based Applications (Corporate Directory and Set-to-Set Messaging) (cont'd.)

Prompt	Response	Description
...	...	= (STSD) Set-to-Set Messaging Denied = STSA, Set-to-Set Messaging Allowed Note: STSD and STSA Class of Service applies to M3903, M3904, and M3905. = (CRPD), Corporate Directory Denied = CRPA, Corporate Directory Allowed Note: (CRPD) and CRPA Class of Service applies to M3903, M3904, and M3905. ...

Table 51
LD 32, Clear or reset a Personal Directory Password for M3900 telephones.

Command	Description
CPWD l s c u	Clear Directory Password and Terminal number, where: l = loop address s = shelf address c = card address u = unit address Note: The clear command allows the system administrator to clear the M3900 Directory password of the specified M3900 Series Digital Telephone. This allows a user to access the M3900 Directory if the password has been forgotten or if the user wants to change the current password.

Table 52
LD 20, Print Terminal Number Block (TNB) data for Virtual and Host Terminals

Prompt	Response	Description
REQ:	PRT	Print data block for the requested terminal type(s)
	LTN	List Terminal Numbers of the requested terminal type(s)

Table 52
LD 20, Print Terminal Number Block (TNB) data for Virtual and Host Terminals (cont'd.)

Prompt	Response	Description
TYPE:	xxxxx	Enter appropriate telephone model where xxxxx:
	3903V	3903V = M3903 Virtual Terminal
	3904V	3904V = M3904 Virtual Terminal
	3903H	3903H = M3903 Host Terminal
	3904H	3904H = M3904 Host Terminal
	TNB	<p>Note 1: Only M3903 and M3904 Digital Telephones can be configured as a Virtual or Host Terminal.</p> <p>Note 2: The Print TNB and List TNB requests always show the logged-off TNB data. In logged-in state, an indication of the logged-in TN ("HOST TN" or "VIRTUAL TN") is added.</p>
...

Table 53
LD 22, Print M3900 peripheral software versions

Prompt	Response	Description
REQ:	PRT	Print
TYPE:	PSWV	Peripheral software versions on disk

Table 54
LD 97, Configure parameters for System-wide Flash Download

Prompt	Response	Description
REQ	CHG	Change Flash Download Parameters
	PRT	Print Flash Download Parameters
TYPE	FDL	Flash Download for M3900 Series Digital Telephone
FDTP	t	<p>Enter M3900 set type selected for Flash Download</p> <p>3902 = M3902</p> <p>3903 = M3903</p> <p>3904 = M3904</p> <p>3905 = M3905</p> <p>ALL = All of the above</p> <p>NONE = None of the above (default)</p> <p>No further prompt; returns to "REQ"</p>

Table 54
LD 97, Configure parameters for System-wide Flash Download (cont'd.)

Prompt	Response	Description
FDTM	(NO) YES	Time interval restriction for Flash Download NO = Do not change time intervals (default) YES = Proceed to change time intervals Note 1: Flash Download is automatically paused one hour before virtual midnight (see TODR in LD 17) to allow midnight routines to run. Note 2: This option is not applicable to reporting.
FDAY	dn	Enter day and number of time intervals for Flash Download. Prompt appears only if FDTM = YES Day is reprompted until carriage return <CR> alone is entered. d = day of the week (0-6 for Sunday to Saturday) n = number of time intervals (0-4); to disallow download for the day, enter 0 Note: If two or more intervals are specified, they must be non-overlapping, non-consecutive, and in increasing order.
FINT	sl	Enter starting hour and length for a time interval. Prompted n times if n>0. s = starting hour (0-23) l = length of interval in hours (1-24)
FTNR	(NO) YES	TN range restriction option for Flash Download NO = no TN restriction (default) YES = specify TN range
FSTN		Starting Terminal Number for Flash Download. Prompt appears only if FTNR = YES.
	l s c u	Format for Large System and CS 1000E system, where l = loop, s = shelf, c = card, u = unit
	c u	Format for Small System, CS 1000S system, Media Gateway 1000B, and Media Gateway 1000T, where c = card and u = unit
FETN		Ending Terminal Number for Flash Download. Prompt appears only if FTNR = YES
	l s c u	Format for Large System and CS 1000E system, where l = loop, s = shelf, c = card, u = unit
	c u	Format for Small System, CS 1000S system, Media Gateway 1000B, and Media Gateway 1000T, where c = card and u = unit

Table 54
LD 97, Configure parameters for System-wide Flash Download (cont'd.)

Prompt	Response	Description
FDNR	(NO) YES	DN range restriction option for Flash Download NO = no DN restriction (default) YES = specify DN range
FDDN	c d1 d2	Flash Download Prime Directory Number range Prompt appears only if FDNR = YES c = Customer number (0-99) d1 = starting Prime DN d2 = ending Prime DN
FRCE	(NO) YES	System-wide Flash Download control option NO = Conditional (default). System-wide Flash Download (via FDLS in LD 32) applies only to an M3900 series set whose flash firmware version is different from the version currently found on the system disk YES = Forced. Force System-wide Flash Download to all of the specified M3900 Series Digital telephones regardless of their current flash firmware versions. Note 1: Use this option with caution! Once the download tree is built (i.e., after executing FDLS in LD 32), this option automatically reverts to NO. Note 2: This option is not applicable to reporting.
FVER	0-99	Flash firmware version specified for full report. If 0, report all versions (default). Note: This option is applicable to reporting only (via FSUM ALL in LD 32).

Table 55
LD 11, Configure Full Duplex Handsfree Class of Service

Prompt	Response	Description
REQ:	NEW CHG	Add new data Change existing data
TYPE:	3904	M3900 series telephone type Full Duplex Handsfree functionality requires an M3904 Phase III set.

Table 55
LD 11, Configure Full Duplex Handsfree Class of Service (cont'd.)

Prompt	Response	Description
...		
CLS	HFA	Handsfree Allowed HFD = Handsfree Denied (default)

Table 56
LD 32, Flash Download commands

Command	Description
FDLU l s c u	Initiate conditional download to one telephone Terminal number, where: l = loop address s = shelf address c = card address u = unit address
FDLI l s c u	Initiate conditional download to an M3900 Series Digital Telephone when it becomes idle.
FDLF l s c u	initiate a forced download to an M3900 Series Digital Telephone regardless of its version and state.
FWVU l s c u	Query and print the firmware versions currently on an M3900 Series Digital Telephone.
FDLS	Initiate system-wide flash download to all, or a specified type of M3900 Series Digital Telephones, based on parameters specified in LD 97
FDLC	Cancel or gracefully stop the system-wide flash download for M3900 Series telephones.
FSUM	Display summary report of current firmware versions on all M3900 Series telephones. The format of the report is as follows: * * M390x SUMMARY REPORT * * dd - ON DISK ff (cc) - nnnn SETS FOUND ff (cc) - nnnn SETS FOUND where x = 2 to 5 for M3902 to M3905 dd = the flash firmware version found on the system disk ff = the downloadable flash firmware version found on the telephone

Table 56
LD 32, Flash Download commands (cont'd.)

Command	Description
FSUM ALL	<p> cc = the core firmware found on the telephone nnnn = the number of telephones found with firmware version ff (cc) </p> <p>Display a complete report on all M3900 Series telephones based on parameters specified in LD 97.</p> <p>The format of the report is as follows:</p> <p>TYPE: tttt CUST: cc PDN: ddddddd TN: l s c u FW: vv</p> <p>where</p> <p> tttt = 3902, 3903, 3904 or 3905 cc = 0-99 ddddddd = the Primary DN of the telephone vv = the flash firmware version </p>

M3900 Flash Download

Contents

This section contains information on the following topics:

- “Introduction” (page 177)
- “Summary of steps” (page 178)
- “Determining software, M3900 PSWV, or firmware versions” (page 202)
 - “X11 software versions” (page 202)
 - “M3900 language PSWV versions” (page 202)
 - “M3900 firmware versions” (page 202)
- “Flash Download advisements” (page 203)
- “PSDL installation” (page 206)
- “Dynamic PSDL installation” (page 206)
- “Detailed Flash Download procedure” (page 208)
- “Configuration parameters in LD 32” (page 212)
 - “Single-Set Flash Download” (page 212)
 - “System-wide Flash Download” (page 213)
- “Print Firmware Versions on M3900 Telephones” (page 216)
- “Query Disk Firmware Versions” (page 218)
- “Commands for system-wide Flash Download of M3900 telephones” (page 220)

Introduction

M3900 Flash Download provides the capability to download a new firmware version from the CS 1000 and Meridian 1 to an M3900 telephone. Flash Download provides a way for installed M3900 telephones to be updated to the appropriate firmware release level for supporting features on the system. Firmware on all M3900 Series Digital Telephones can be upgraded using Flash Download, with the exception of the M3901. Flash Download can be invoked for one M3900 telephone, for a group of M3900

telephones, or all telephones on the system. It can be invoked locally or remotely for maintenance purposes. Features of the flash download procedure include the following:

- Telephone type can be specified (M3902, M3903, M3904, M3905, All)
- Day(s) of week can be specified
- Up to four intervals per day can be specified (start time, length)
- TN Range can be specified (start TN, end TN)
- DN Range can be specified (start DN, end DN)
- Force Download can be specified (yes, no)

Flash download is incorporated in the existing Peripheral SoftWare Version (PSWV) background tasks of the Work Schedule. Therefore, regular call processing is impacted as little as possible. In the context of this document, PSWV represents the firmware file that is downloaded to an M3900 telephone. It is sometimes referred to as a Peripheral Software DownLoad (PSDL). PSDL is a file that holds PSWV for hardware (for example, terminals or trunk cards) that supports a firmware upgrade.

Flash Download requires the use of two software overlays. Use LD 97 to configure the parameters for the Flash Download capability. Use LD 32 to run the feature. Before the Flash Download feature is used, configure the feature in LD 97.

Summary of steps

See [Table 57 "Flash Download procedure matrix for Small Systems" \(page 179\)](#) and [Table 58 "Flash Download procedure matrix for Large Systems" \(page 189\)](#) for the overall steps needed to perform a flash download. [Table 57 "Flash Download procedure matrix for Small Systems" \(page 179\)](#) is for Small Systems and [Table 58 "Flash Download procedure matrix for Large Systems" \(page 189\)](#) is for Large Systems. These tables list the versions of system software that an M3900 customer could be running and the high-level steps needed to upgrade to the latest Reissue software. The tables reference ["PSDL installation" \(page 206\)](#) for the steps to install the M3900 language set, PSWV. The tables also reference the ["Detailed Flash Download procedure" \(page 208\)](#) for the step-by-step procedure for flash downloading firmware to the M3900 Series Digital Telephones.

If you have difficulties in determining versions of X11 software, M3900 PSWV language files or firmware, refer to ["Determining software, M3900 PSWV, or firmware versions" \(page 202\)](#).

Table 57
Flash Download procedure matrix for Small Systems

Present software	Upgrade to software	Keycode required	M3900 telephones	Upgrade steps
24.24	25.08 (Re-issue)	Yes	Phase I	<ol style="list-style-type: none"> 1. Call Nortel technical support to find out how to obtain any necessary upgrades. <ul style="list-style-type: none"> • A SIM upgrade from 8 to 16 Meg is required. • An upgrade from MAT 6.5 is required. 2. Download software from the web. 3. Follow the “PSDL installation” (page 206). 4. Install manufactured patches. 5. Download firmware to telephones, following the Flash Download procedure.
			Phase II, Phase III	<p>Note: This is not a standard process. M3900 Phase II/III phones should not be configured on a Release 24.2x system.</p> <ol style="list-style-type: none"> 1. Follow the Small System Release 24.2x to Release 25.08 Reissue procedure for Phase I telephones (above). <p>The Release 25.08 Reissue contains M3900 Phase I firmware for M3902 and M3905 telephones and Phase II firmware for M3903 and M3904 telephones. Follow the Flash Download process to downgrade the M3900 Phase II phones to Phase II/III firmware.</p>

Table 57
Flash Download procedure matrix for Small Systems (cont'd.)

Present software	Upgrade to software	Keycode required	M3900 telephones	Upgrade steps
	25.15 Re-issue	Yes	Phase I	Follow the standard software order process.
			Phase II	<p>Note: This is not a standard process. M3900 Phase II/III phones should not be configured on a Release 24.2x system.</p> <p>1. Follow the Small System Release 24.2x to Release 25.15 Re-issue procedure for Phase I telephones (above).</p> <p>The Release 25.15 Re-issue contains M3900 Phase I firmware for M3905 telephones and Phase II firmware for M3902, M3903, and M3904 telephones. Follow the Flash Download process to downgrade the M3900 Phase III phones to Phase I/II firmware.</p>
	25.30	Yes	Phase I	Follow the standard software order process.
	25.40, 25.40B	Yes	Phase II, Phase III	<p>Note: This is not a standard process. M3900 Phase II/III phones should not be configured on a Release 24.2x system.</p> <p>1. Follow the Small System Release 24.2x to Release 25.30 Re-issue procedure for Phase I telephones (above).</p> <p>The Release 25.30 contains M3900 Phase I firmware for M3905 telephones and Phase II firmware for M3902, M3903, and M3904 telephones. Follow the Flash Download process to downgrade the M3900 Phase III phones to Phase I/II firmware.</p>
			Phase I	Follow the standard software order process.

Table 57
Flash Download procedure matrix for Small Systems (cont'd.)

Present software	Upgrade to software	Keycode required	M3900 telephones	Upgrade steps
			Phase II, Phase III	<p>Note: This is not a standard process. M3900 Phase II/III phones should not be configured on a Release 24.2x system.</p> <p>1. Follow the Small System Release 24.2x to Release 25.40/25.40B procedure for Phase I telephones (above).</p> <p>The Releases 25.40 and 25.40B contain M3900 Phase III firmware for M3900 telephones.</p>
Present software	Upgrade to software	Keycode required	M3900 telephones	Upgrade steps
	03.00	Yes	Phase I	Follow the standard software order process.
			Phase II, Phase III	<p>Note: This is not a standard process. M3900 Phase II/III phones should not be configured on a Release 24.2x system.</p> <p>1. Follow the Small System Release 24.2x to Release 03.00 Re-issue procedure for Phase I telephones (above).</p> <p>The Release 03.00 contains M3900 Phase III firmware for M3900 telephones.</p>
	04.00	Yes	Phase I	Follow the standard software order process.
			Phase II, Phase III	<p>Note: This is not a standard process. M3900 Phase II/III phones should not be configured on a Release 24.2x system.</p> <p>1. Follow the Small System Release 24.2x to Release 04.00 Re-issue procedure for Phase I telephones (above).</p>

Present software	Upgrade to software	Keycode required	M3900 telephones	Upgrade steps	
				The Release 04.00 contains M3900 Phase III firmware for M3900 telephones.	
25.08	25.08 Re-issue	No	Phase I, Phase II	<ol style="list-style-type: none"> 1. Download software from the web. 2. Follow "PSDL installation" (page 206). 3. Install manufactured patches. 4. Download firmware to telephones, following the Flash Download procedure. 	
			Phase III	<p>Note: This is not a standard process. M3900 Phase III phones should not be configured on a Release 25.08 system.</p> <ol style="list-style-type: none"> 1. Follow the Small System Release 25.08 to Release 25.08 Re-issue procedure for Phase I/II telephones (above). <p>The 25.08 Reissue contains M3900 Phase I firmware for M3902 and M3905 telephones and Phase II firmware for M3903 and M3904 telephones. Follow the Flash Download process to downgrade the M3900 Phase III phones to Phase I/II firmware.</p>	
	25.15 Re-issue		Yes	Phase I, Phase II	Follow the standard software order process.
				Phase III	<p>Note: This is not a standard process. M3900 Phase III phones should not be configured on a Release 25.08 system.</p> <ol style="list-style-type: none"> 1. Follow the Small System Release 25.08 to Release 25.15 Re-issue procedure for Phase I and Phase II telephones (above).

Present software	Upgrade to software	Keycode required	M3900 telephones	Upgrade steps
				<p>The 25.08 Re-issue contains M3900 Phase I firmware for M3905 telephones and Phase II firmware for M3902, M3903, and M3904 telephones. Follow the Flash Download process to downgrade the M3900 Phase III phones to Phase I/II firmware.</p>
	25.10 Re-issue	Yes	Phase I, Phase II	<p>1. Call Nortel technical support to find out how to obtain any necessary upgrades.</p> <p>2. Determine M3900 PSWV to install (see Table 61 "Firmware and PSWV versions" (page 218)).</p> <p>Note: Select PSWV #5 (Phase I firmware for X11 Release 24; second PC card is needed) only if the customer is just running the Release 24 M3900 features.</p> <p>3. Download software from the web with the appropriate PSWV language file.</p> <p>4. Follow the PSDL Installation Procedure (see "PSDL installation" (page 206)) to install software with the selected M3900 PSWV file.</p> <p>5. Install the manufactured patch.</p> <p>6. Download firmware to the telephones, following the Flash Download procedure.</p>

Present software	Upgrade to software	Keycode required	M3900 telephones	Upgrade steps
			Phase III	<p>Note: This is not a standard process. M3900 Phase III phones should not be configured on a Release 25.08 system.</p> <p>1. Follow the Small System Release 25.08 to Release 25.10 Re-issue procedure for Phase I and Phase II telephones (above).</p> <p>The 25.10 Re-issue contains M3900 Phase I firmware for M3902 and M3905 telephones and Phase II firmware for M3903 and M3904 telephones. Follow the Flash Download process to downgrade the M3900 Phase III phones to Phase I/II firmware.</p>
	25.30	Yes	Phase I, Phase II	Follow the standard software order process.
			Phase III	<p>Note: This is not a standard process. M3900 Phase III phones should not be configured on a Release 25.08 system.</p> <p>1. Follow the Small System Release 25.08 to Release 25.30 procedure for Phase I and Phase II telephones (above).</p> <p>The Release 25.30 contains M3900 Phase I firmware for M3905 telephones and Phase II firmware for M3902, M3903, and M3904 telephones. Follow the Flash Download process to downgrade the M3900 Phase III phones to Phase I/II firmware.</p>

Present software	Upgrade to software	Keycode required	M3900 telephones	Upgrade steps
	25.40, 25.40B	Yes	Phase I, Phase II	Follow the standard software order process.
			Phase III	<p>Note: This is not a standard process. M3900 Phase III phones should not be configured on a Release 25.08 system.</p> <p>1. Follow the Small System Release 25.08 to Release 25.40/25.40B Re-issue procedure for Phase I and Phase II telephones (above).</p> <p>The Releases 25.40 and 25.40B contain M3900 Phase III firmware for M3900 telephones.</p>
	03.00	Yes	Phase I, Phase II	Follow the standard software order process.
			Phase III	<p>Note: This is not a standard process. M3900 Phase III phones should not be configured on a Release 25.08 system.</p> <p>1. Follow the Small System Release 25.08 to Release 03.00 Re-issue procedure for Phase I and Phase II telephones (above).</p> <p>The Release 03.00 contains M3900 Phase III firmware for M3900 telephones.</p>
	04.00	Yes	Phase I, Phase II	Follow the standard software order process.
			Phase III	<p>Note: This is not a standard process. M3900 Phase III phones should not be configured on a Release 25.08 system.</p> <p>1. Follow the Small System Release 25.08 to Release 04.00 Re-issue procedure for Phase I and Phase II telephones (above).</p> <p>The Release 04.00 contains M3900 Phase III firmware for M3900 telephones.</p>

Present software	Upgrade to software	Keycode required	M3900 telephones	Upgrade steps
25.15	25.15 Reissue	No	Phase I, Phase II	<p>1. Determine M3900 PSWV to install (see Table 61 "Firmware and PSWV versions" (page 218)).</p> <p>Select PSWV #1 Global or #4 N.A. (25% savings; second PC card needed).</p> <p>Note: Select PSWV #5 (Release 1 firmware for X11 Release 24; second PC card needed) only if the customer is just running the Release 24 M3900 features.</p> <p>2. Download software from the web with appropriate PSWV language file.</p> <p>3. Follow the PSDL Installation Procedure, see "PSDL installation" (page 206) to install software with the selected M3900 PSWV file.</p> <p>4. Install manufactured patches.</p> <p>5. Download firmware to telephones, following the Flash Download procedure.</p>
			Phase III	<p>Note: This is not a standard process. M3900 Phase III phones should not be configured on a Release 25.15 system.</p> <p>1. Follow the Small System Release 25.15 to Release 25.15 Re-issue procedure for Phase I and Phase II telephones (above).</p> <p>The Release 25.15 Re-issue contains M3900 Phase I firmware for M3905 telephones and Phase II firmware for M3902, M3903, and M3904 telephones. Follow the Flash Download process to downgrade the M3900 Phase III phones to Phase I/II firmware.</p>

Present software	Upgrade to software	Keycode required	M3900 telephones	Upgrade steps
	25.30	Yes	Phase I, Phase II	Follow the standard software order process.
			Phase III	<p>Note: This is not a standard process. M3900 Phase III phones should not be configured on a Release 25.15 system.</p> <p>1. Follow the Small System Release 25.15 to Release 25.30 procedure for Phase I and Phase II telephones (above).</p> <p>The Release 25.30 contains M3900 Phase I firmware for M3905 telephones and Phase II firmware for M3902, M3903, and M3904 telephones. Follow the Flash Download process to downgrade the M3900 Phase III phones to Phase I/II firmware.</p>
	25.40, 25.40B	Yes	Phase I, Phase II	Follow the standard software order process.
			Phase III	<p>Note: This is not a standard process. M3900 Phase III phones should not be configured on a Release 25.15 system.</p> <p>1. Follow the Small System Release 25.15 to Release 25.40/25.40B procedure for Phase I and Phase II telephones (above).</p> <p>The Releases 25.40 and 25.40B contain M3900 Phase III firmware for M3900 telephones.</p>
	03.00	Yes	Phase I, Phase II	Follow the standard software order process.
			Phase III	<p>Note: This is not a standard process. M3900 Phase III phones should not be configured on a Release 25.15 system.</p> <p>1. Follow the Small System Release 25.15 to Release 03.00 Re-issue procedure for Phase I and Phase II telephones (above).</p>

Present software	Upgrade to software	Keycode required	M3900 telephones	Upgrade steps
				The Release 03.00 contains M3900 Phase III firmware for M3900 telephones.
	04.00	Yes	Phase I, Phase II	Follow the standard software order process.
			Phase III	<p>Note: This is not a standard process. M3900 Phase III phones should not be configured on a Release 25.15 system.</p> <p>1. Follow the Small System Release 25.15 to Release 04.00 Re-issue procedure for Phase I and Phase II telephones (above).</p> <p>The Release 04.00 contains M3900 Phase III firmware for M3900 telephones.</p>

Present software	Upgrade to software	Keycode required	M3900 telephones	Upgrade steps
25.30	25.40, 25.40B	Yes	Phase I, Phase II	Follow the standard software order process.
			Phase III	<p>Note: This is not a standard process. M3900 Phase III phones should not be configured on a Release 25.30 system.</p> <p>1. Follow the Small System Release 25.30 to Release 25.40/25.40B Re-issue procedure for Phase I and Phase II telephones (above).</p> <p>The Releases 25.40 and 25.40B contain M3900 Phase III firmware for M3900 telephones.</p>
	03.00	Yes	Phase I, Phase II	Follow the standard software order process.
			Phase III	<p>Note: This is not a standard process. M3900 Phase III phones should not be configured on a Release 25.30 system.</p>

Present software	Upgrade to software	Keycode required	M3900 telephones	Upgrade steps
				<p>1. Follow the Small System Release 25.30 to Release 03.00 Re-issue procedure for Phase I and Phase II telephones (above).</p> <p>The Release 03.00 contains M3900 Phase III firmware for M3900 telephones.</p>
	04.00	Yes	Phase I, Phase II	Follow the standard software order process.
			Phase III	<p>Note: This is not a standard process. M3900 Phase III phones should not be configured on a Release 25.30 system.</p> <p>1. Follow the Small System Release 25.30 to Release 04.00 Re-issue procedure for Phase I and Phase II telephones (above).</p> <p>The Release 04.00 contains M3900 Phase III firmware for M3900 telephones.</p>
25.40, 25.40B	03.00	Yes	Phase I, Phase II, Phase III	Follow the standard software order process.
	04.00	Yes	Phase I, Phase II, Phase III	Follow the standard software order process.
03.00	04.00	Yes	Phase I, Phase II, Phase III	Follow the standard software order process.

Table 58
Flash Download procedure matrix for Large Systems

Present software	Upgrade to software	Keycode required	M3900 telephones	Upgrade steps
24.25	25.08 Re-issue	Yes	Phase I	1. Call Nortel technical support to find out how to obtain any necessary upgrades.

Present software	Upgrade to software	Keycode required	M3900 telephones	Upgrade steps
				<p>2. Follow the PSDL Installation Procedure (see “PSDL installation” (page 206)).</p> <p>4. Install the manufactured patches.</p> <p>5. Download the firmware to the telephones, following the Flash Download procedure.</p>
			Phase II, Phase III	<p>Note: This is not a standard process. There should not be M3900 Phase II and Phase III telephones on a Release 24.2x system.</p> <p>1. Follow the Large System Release 24.2x to 25.08 Re-issue procedure for Phase 1 telephones (above).</p> <p>The Release 25.08 Re-issue contains M3900 Phase I firmware for M3902 and M3905 telephones and Phase II firmware for M3903 and M3904 telephones. Follow the Flash Download process to downgrade the M3900 Phase III telephones to Phase I/II firmware.</p>
	25.15 Re-issue	Yes	Phase I	Follow the standard software order process.
			Phase II, Phase III	<p>Note: This is not a standard process. There should not be M3900 Phase II and Phase III telephones on a Release 24.2x system.</p> <p>1. Follow the Large System Release 24.2x to 25.15 Re-issue procedure for Phase 1 telephones (above).</p>

Present software	Upgrade to software	Keycode required	M3900 telephones	Upgrade steps
				The Release 25.15 Re-issue contains M3900 Phase I firmware for M3905 telephones and Phase II firmware for M3902, M3903, and M3904 telephones. Follow the Flash Download process to downgrade the M3900 Phase III telephones to Phase I/II firmware.
	25.30	Yes	Phase I	Follow the standard software order process.
			Phase II, Phase III	<p>Note: This is not a standard process. There should not be M3900 Phase II and Phase III telephones on a Release 24.2x system.</p> <p>1. Follow the Large System Release 24.2x to 25.30 procedure for Phase I telephones (above).</p> <p>The Release 25.30 contains M3900 Phase I firmware for M3905 telephones and Phase II firmware for M3902, M3903, and M3904 telephones. Follow the Flash Download process to downgrade the M3900 Phase III telephones to Phase I/II firmware.</p>
	25.40, 25.40B	Yes	Phase I	Follow the standard software order process.
			Phase II, Phase III	<p>Note: This is not a standard process. There should not be M3900 Phase II and Phase III telephones on a Release 24.2x system.</p> <p>1. Follow the Large System Release 24.2x to 25.40/25.40B procedure for Phase I telephones (above).</p>

Present software	Upgrade to software	Keycode required	M3900 telephones	Upgrade steps
				The Releases 25.40 and 25.40B contain M3900 Phase III firmware for M3900 telephones.
	03.00	Yes	Phase I	Follow the standard software order process.
			Phase II, Phase III	Note: This is not a standard process. There should not be M3900 Phase II and Phase III telephones on a Release 24.2x system. 1. Follow the Large System Release 24.2x to 03.00 procedure for Phase I telephones (above). The Release 03.00 contains M3900 Phase III firmware for M3900 telephones.
	04.00	Yes	Phase I	Follow the standard software order process.
			Phase II, Phase III	Note: This is not a standard process. There should not be M3900 Phase II and Phase III telephones on a Release 24.2x system. 1. Follow the Large System Release 24.2x to 04.00 procedure for Phase I telephones (above). The Release 04.00 contains M3900 Phase III firmware for M3900 telephones.

Present software	Upgrade to software	Keycode required	M3900 telephones	Upgrade steps
25.08	25.08 Re-issue	No	Phase I, Phase II	<ol style="list-style-type: none"> 1. Call Nortel technical support to find out how to obtain any necessary upgrades. 2. Follow the PSDL Installation Procedure (see "PSDL installation" (page 206)). 4. Install the manufactured patches. 5. Download the firmware to telephones, following the Flash Download procedure.
			Phase III	<p>Note: This is not a standard process. There should not be M3900 Phase III phones configured on a 25.08 system.</p> <ol style="list-style-type: none"> 1. Follow the Large System 25.08 to 25.08 Re-issue procedure for Release 1 telephones (above). <p>The 25.08 Re-issue contains M3900 Phase I firmware for M3902 and M3905 telephones and Phase II firmware for M3903 and M3904 telephones. Follow the Flash Download process to downgrade the M3900 Phase III phones to Phase I/II firmware.</p>
	25.15 Re-issue	Yes	Phase I, Phase II	Follow the standard software order process.
			Phase III	<p>Note: This is not a standard process. There should not be M3900 Phase III phones configured on a 25.08 system.</p> <ol style="list-style-type: none"> 1. Follow the Large System 25.08 to 25.15 Re-issue procedure for Phase I/II telephones (above).

Present software	Upgrade to software	Keycode required	M3900 telephones	Upgrade steps
				The Release 25.15 Re-issue contains M3900 Phase I firmware for M3905 telephones and Phase II firmware for M3902, M3903, and M3904 telephones. Follow the Flash Download process to downgrade the M3900 Phase III phones to Phase I/II firmware.
	25.30	Yes	Phase I, Phase II	Follow the standard software order process.
			Phase III	<p>Note: This is not a standard process. There should not be M3900 Phase III phones configured on a 25.08 system.</p> <p>1. Follow the Large System 25.08 to 25.30 Re-issue procedure for Phase I/II telephones (above).</p> <p>The Release 25.30 Re-issue contains M3900 Phase I firmware for M3905 telephones and Phase II firmware for M3902, M3903, and M3904 telephones. Follow the Flash Download process to downgrade the M3900 Phase III phones to Phase I/II firmware.</p>
	25.40, 25.40B	Yes	Phase I, Phase II	Follow the standard software order process.
			Phase III	<p>Note: This is not a standard process. There should not be M3900 Phase III phones configured on a 25.08 system.</p> <p>1. Follow the Large System Release 25.08 to 25.40/25.40B procedure for Phase I/II telephones (above).</p>

Present software	Upgrade to software	Keycode required	M3900 telephones	Upgrade steps
				The Releases 25.40 and 25.40B contain M3900 Phase III firmware for M3900 telephones.
	03.00	Yes	Phase I, Phase II	Follow the standard software order process.
			Phase III	<p>Note: This is not a standard process. There should not be M3900 Phase III phones configured on a 25.08 system.</p> <p>1. Follow the Large System Release 25.08 to 03.00 procedure for Phase I/II telephones (above).</p> <p>The Release 03.00 contains M3900 Phase III firmware for M3900 telephones.</p>
	04.00	Yes	Phase I, Phase II	Follow the standard software order process.
			Phase III	<p>Note: This is not a standard process. There should not be M3900 Phase III phones configured on a 25.08 system.</p> <p>1. Follow the Large System Release 25.08 to 04.00 procedure for Phase I/II telephones (above).</p> <p>The Release 04.00 contains M3900 Phase III firmware for M3900 telephones.</p>
25.10	25.15 Re-issue	Yes	Phase I, Phase II	Follow the standard software order process.
			Phase III	<p>Note: This is not a standard process. There should not be M3900 Phase III phones configured on a 25.10 system.</p> <p>1. Follow the Large System Release 25.10 to 25.15 Re-issue procedure for Phase I/II telephones (above).</p>

Present software	Upgrade to software	Keycode required	M3900 telephones	Upgrade steps
				The Release 25.15 Re-issue contains M3900 Phase I firmware for M3905 telephones and Phase II firmware for M3902, M3903, and M3904 telephones. Follow the Flash Download process to downgrade the M3900 Phase III phones to Phase I/II firmware.

Present software	Upgrade to software	Keycode required	M3900 telephones	Upgrade steps
	25.30	Yes	Phase I, Phase II	Follow the standard software order process.
			Phase III	<p>Note: This is not a standard process. There should not be M3900 Phase III phones configured on a 25.10 system.</p> <p>1. Follow the Large System Release 25.10 to 25.30 Re-issue procedure for Phase I/II telephones (above).</p> <p>The Release 25.30 Re-issue contains M3900 Phase I firmware for M3905 telephones and Phase II firmware for M3902, M3903, and M3904 telephones. Follow the Flash Download process to downgrade the M3900 Phase III phones to Phase I/II firmware.</p>
	25.40, 25.40B	Yes	Phase I, Phase II	Follow the standard software order process.
			Phase III	<p>Note: This is not a standard process. There should not be M3900 Phase III phones configured on a 25.10 system.</p>

Present software	Upgrade to software	Keycode required	M3900 telephones	Upgrade steps
				<p>1. Follow the Large System Release 25.10 to 25.40/25.40B procedure for Phase I/II telephones (above).</p> <p>The Releases 25.40 and 25.40B contain M3900 Phase III firmware for M3900 telephones.</p>
	03.00	Yes	Phase I, Phase II	Follow the standard software order process.
			Phase III	<p>Note: This is not a standard process. There should not be M3900 Phase III phones configured on a 25.10 system.</p> <p>1. Follow the Large System Release 25.10 to 03.00 procedure for Phase I/II telephones (above).</p> <p>The Releases 03.00 contains M3900 Phase III firmware for M3900 telephones.</p>
	04.00	Yes	Phase I, Phase II	Follow the standard software order process.
			Phase III	<p>Note: This is not a standard process. There should not be M3900 Phase III phones configured on a 25.10 system.</p> <p>1. Follow the Large System Release 25.10 to 04.00 procedure for Phase I/II telephones (above).</p> <p>The Releases 04.00 contains M3900 Phase III firmware for M3900 telephones.</p>

Present software	Upgrade to software	Keycode required	M3900 telephones	Upgrade steps
25.15	25.15 Re-issue	No	Phase I, Phase II	<p>1. Determine M3900 PSWV to install (see Table 61 "Firmware and PSWV versions" (page 218)).</p> <p>Select PSWV #1 Global or #4 N.A. (25% savings; second PC card needed).</p> <p>Note: Select PSWV #5 (Release 1 firmware for X11 Release 24; second PC card needed) only if the customer is just running the Release 24 M3900 features.</p> <p>2. Download software from the web with appropriate PSWV language file.</p> <p>3. Follow the procedure "PSDL installation" (page 206) to install software with the selected M3900 PSWV file.</p> <p>4. Install manufactured patches.</p> <p>5. Download firmware to telephones, following the Flash Download procedure.</p>
			Phase III	<p>Note: This is not a standard process. There should not be M3900 Phase III phones configured on a 25.15 system.</p> <p>1. Follow the Large System Release 25.15 to 25.15 Re-issue procedure for Phase I/II telephones (above).</p> <p>The Release 25.15 Re-issue contains M3900 Phase I firmware for M3905 telephones and Phase II firmware for M3902, M3903, and M3904 telephones. Follow the Flash</p>

Present software	Upgrade to software	Keycode required	M3900 telephones	Upgrade steps
				Download process to downgrade the M3900 Phase III phones to Phase I/II firmware.
	25.30	Yes	Phase I, Phase II	Follow the standard software order process.
			Phase III	<p>Note: This is not a standard process. There should not be M3900 Phase III phones configured on a Release 25.15 system.</p> <p>1. Follow the Large System Release 25.15 to 25.30 Re-issue procedure for Phase I/II telephones (above).</p> <p>The Release 25.30 Re-issue contains M3900 Phase I firmware for M3905 telephones and Phase II firmware for M3902, M3903, and M3904 telephones. Follow the Flash Download process to downgrade the M3900 Phase III phones to Phase I/II firmware.</p>
	25.40, 25.40B	Yes	Phase I, Phase II	Follow the standard software order process.
			Phase III	<p>Note: This is not a standard process. There should not be M3900 Phase III phones configured on a Release 25.15 system.</p> <p>1. Follow the Large System Release 25.15 to 25.40/25.40B procedure for Phase I/II telephones (above).</p> <p>The Releases 25.40 and 25.40B contain M3900 Phase III firmware for M3900 telephones.</p>

Present software	Upgrade to software	Keycode required	M3900 telephones	Upgrade steps
	03.00	Yes	Phase I, Phase II	Follow the standard software order process.
			Phase III	<p>Note: This is not a standard process. There should not be M3900 Phase III phones configured on a Release 25.15 system.</p> <p>1. Follow the Large System Release 25.15 to 03.00 procedure for Phase I/II telephones (above).</p> <p>The Release 03.00 contains M3900 Phase III firmware for M3900 telephones.</p>
	04.00	Yes	Phase I, Phase II	Follow the standard software order process.
			Phase III	<p>Note: This is not a standard process. There should not be M3900 Phase III phones configured on a Release 25.15 system.</p> <p>1. Follow the Large System Release 25.15 to 04.00 procedure for Phase I/II telephones (above).</p> <p>The Release 04.00 contains M3900 Phase III firmware for M3900 telephones.</p>
25.30	25.40, 25.40B	Yes	Phase I, Phase II	Follow the standard software order process.
			Phase III	<p>Note: This is not a standard process. There should not be M3900 Phase III phones configured on a Release 25.30 system.</p> <p>1. Follow the Large System Release 25.30 to 25.40/25.40B procedure for Phase I/II telephones (above).</p>

Present software	Upgrade to software	Keycode required	M3900 telephones	Upgrade steps
				The Releases 25.40 and 25.40B contain M3900 Phase III firmware for M3900 telephones.
	03.00	Yes	Phase I, Phase II	Follow the standard software order process.
			Phase III	Note: This is not a standard process. There should not be M3900 Phase III phones configured on a Release 25.30 system. 1. Follow the Large System Release 25.30 to 03.00 procedure for Phase I/II telephones (above). The Release 03.00 contains M3900 Phase III firmware for M3900 telephones.
	04.00	Yes	Phase I, Phase II	Follow the standard software order process.
			Phase III	Note: This is not a standard process. There should not be M3900 Phase III phones configured on a Release 25.30 system. 1. Follow the Large System Release 25.30 to 04.00 procedure for Phase I/II telephones (above). The Release 04.00 contains M3900 Phase III firmware for M3900 telephones.
25.40, 25.40B	03.00	Yes	Phase I, Phase II, Phase III	Follow the standard software order process.
	04.00	Yes	Phase I, Phase II, Phase III	Follow the standard software order process.
03.00	04.00	Yes	Phase I, Phase II, Phase III	Follow the standard software order process.

Determining software, M3900 PSWV, or firmware versions

X11 software versions

Use the ISS command in LD 22 to identify X11 software versions. When trying to determine whether a system's software has been upgraded to the Reissue of 25.08 or 25.15, patches MPLR13167 and MPLR13247 must be loaded and the LD 22 ISS command must be issued. If "PSWV Version 32" appears for X11 Release 25.08 software, the 25.08 Reissue software has been loaded. If "PSWV Version 33" appears for X11 Release 25.15 software, the 25.15 Reissue software has been loaded.

M3900 language PSWV versions

To find the M3900 Language PSWV version on Small Systems, see related procedures in *Communication Server 1000M and Meridian 1 Small System Software Upgrade (NN43011-459)* (). The system then prints the M3900 Language PSWV file version and name, which is referenced in [Table 61 "Firmware and PSWV versions" \(page 218\)](#).

To find the M3900 Language PSWV version on Large Systems, follow the appropriate Large System procedure in *Communication Server 1000M and Meridian 1 Large System Upgrades Overview (NN43021-458)* (). When you get to the PSDL Installation menu under the Install M3900 telephone Language menu, select item 2 "List 3900 telephone languages". The system then displays the PSDL file that is currently installed on the machine, as well as other PSWV files available to install.

An alternative procedure for both large and Small Systems is to download an M3900 telephone on the system and query the language version for that telephone through the telephone's display diagnostics. See ["M3900 firmware versions" \(page 202\)](#) for information on obtaining the firmware version through display diagnostics. Once the firmware version has been obtained, it can be cross referenced to the M3900 PSWV language version in [Table 61 "Firmware and PSWV versions" \(page 218\)](#).

M3900 firmware versions

Use the FWVU command in LD 32 to obtain the firmware version of an M3900 telephone. The firmware version or language version can be found through the display diagnostics on the M3900 telephone. You can obtain the display diagnostics through the following procedure.

Procedure 44 Displaying the M3900 Diagnostics

Step	Action
1	Press the Options key on the M3900 telephone.
2	Scroll to the Display Diagnostics entry, using the up or down navigation keys.

- 3 Press the **Select** soft key.
- 4 Scroll to the screen that shows the language file and firmware version using the up or down navigation keys.

--End--

For the latest firmware versions contained in the X11 software Reissue, refer to [Table 61 "Firmware and PSWV versions" \(page 218\)](#). For information on firmware versions which fix particular M3900 problems, refer to Matrix G in the latest version of the M3900 Series Digital Telephone Advisory Bulletin.

The general rules for identifying which versions of firmware are Release 1 and which are Release 2 for the M3903, M3904 and M3905 telephones are as follows:

- Phase 1 firmware vintages are less than version 4.0 (<40 from LD 32 FWVU response).
- Phase 2 firmware vintages are greater or equal to version 4.0 (>= 40 from LD 32 FWVU response) but less than version 6.0 (<60 from LD 32 FWVU response).
- Phase 3 firmware vintages are greater or equal to version 6.0 (>=60 from LD 32 FWVU response).

Flash Download advisements

Since the Flash Downloading feature of the M3900 takes some bandwidth from the system signaling path while it is operating, it is recommended that downloading be scheduled in off-peak hours for best results. There is some real time impact to the system since the system processor is busy doing the downloads. However, there is no impact to call processing, since call processing has a higher priority. Therefore, downloads take longer during peak traffic times because the system processor is busy doing call processing and cannot devote as much time to the M3900 downloads. There is no difference between Large Systems and Small Systems for this.

When a system is first brought into service with M3900 telephones, there is a significant amount of messaging that occurs to activate the telephones through the Lamp Audit background routine. The time required to bring all telephones into service on a system is dependent on the system configuration, and could take several hours. Performing a Flash Download directly after the system is brought into service adds to the message load on the system. Therefore, it is recommended that M3900 telephone download activities not occur in conjunction with systems being brought into service. Instead downloads should occur 24 hours after a system is brought into service.

If a user attempts to use a telephone during a flash download, all telephone activity is ignored.

When performing a flash download to an M3900 port that does not have a telephone installed, or downloading to an M3900 port that has the wrong M3900 telephone type installed, an SDL2110 error message is printed out at the system.

During the middle of flash download operation, if the telephone is disconnected or if the telephone fails download for any reason, the telephone is rendered inoperable. Flash downloading must run to completion before the telephone can be made operable.

For the manual individual download operation, if the telephone is not responding (is not operational) or if the telephone is not a M3900 telephone, flash download fails.

If the firmware file(s) used as the source for flash download to M3900 telephones are not present (in the proper location) on the system disks, the flash download operation fails.

While a system-wide flash download operation is in progress, attempts to disable telephones that are currently being downloaded result in an SCH1958 message that is printed with the list of telephones involved. If a loop, shelf, or card that contains the telephones being downloaded is disabled, then the download to the telephones on that loop, shelf, or card fails.

According to the existing PSWV logic, when PSWV is in progress, an attempt to load an overlay is denied and result in an OVL0306 message.

Nortel strongly recommends that you not force load an overlay (load with a Suspend option) unless there is an emergency while PSWV is in progress. In this instance, existing PSWV logic aborts downloading for the current PSWV block (of cards or telephones of a given type being downloaded) and restarts the download for that block and remaining ones after the overlay is exited. If this happens to M3900 flash download, the block of telephones are out-of-service for a lengthy period of time and this prolongs the completion of the system-wide flash download.

If system warm-start (Initialization) or cold-start (Sysload) occurs while flash download is in progress, the download process is aborted abruptly. Any telephones which are in the middle of download fail to complete firmware download and are left inoperable. You must re-enter the single-telephone or system-wide flash download command later to restart and complete the download. For system-wide downloads, any previously scheduled telephones are no longer queued for download.

While a manual individual download operation is still in progress, do not abort LD 32 (except in an emergency) by using the **** command. If the overlay is aborted before completing the download, the telephone is left inoperable until a flash download command for the telephone is re-entered and completed at a later time.

During system wide download, you can use all overlays by issuing the ld x susp command. However, this ungracefully stops the download to the current group of telephones that are being downloaded and leaves them without firmware until the overlay is exited. The download to these telephones is then started again.

While a system-wide flash download operation is in progress:

- Service change (CHG, MOV, or OUT) to a unit that is currently being downloaded is blocked in LD 11. An SCH1958 message is printed.
- Move (MOV) or remove (OUT through LD 11 or Automatic Set Relocation) to an M3900 telephone before its flash download starts prevents download to the telephone in this cycle of system-wide flash download.
- A new M3900 telephone added (through LD 11 or Automatic Set Relocation) after the FDLS command is issued is not included in this round of system-side download.

When scheduling the Flash Download of telephones, note that one hour before the Midnight routines execute, the flash download process is gracefully stopped. The Flash downloading resumes once midnight routines are executed.

When a schedule is defined in LD 97 and the Flash Download is started (by entering the FDLS command in LD 32), all scheduled telephones are queued for download. The download process remains active in the background until the download is complete or is canceled (using the FDLC command in LD 32). If the download is active in the background (telephones not actively downloading per the scheduled download time) and the download schedule is removed in LD 97, the download begins immediately for the telephones that remain in the download queue. Use the LD x SUSP command to load an overlay when the download is active in the background (scheduled but not actively downloading telephones). It is also not possible to perform a single telephone download (FDLU, FDLI, or FDLF command from LD 32) while the download is active in the background. If an individual download is attempted in this case, the system indicates that the PSDL is not idle. If an individual telephone download is necessary while the download is active in the background, you

must cancel the download in LD 32 using the FDLC command. Once the individual downloads are complete, you can restart the schedule download with the FLDS command in LD 32.

Note: If the force option is used with the FDLS command, all telephones in the original schedule are downloaded.

For M3900 telephones actively being flash downloaded when the Flash Download Cancel FDLC command is issued, the flash download to these telephones is completed before the flash download process cancels.

M3905 telephones acquired by the Symposium Call Center Server (SCCS) do not have to be de-acquired (pulled out of all queues) before the flash download is started. However, during the download, the agent using the M3905 telephone is placed in a maintenance-busy state for approximately 12 minutes. As a result, the SCCS is not able to record any agent statistics for agents using the M3905 telephones during the download. The SCCS agent reports for the interval in which the download occurred will, therefore, be inaccurate.

PSDL installation

During a flash download, the system downloads the contents of a PSDL/PSWV file to an M3900 telephone. This PSDL Installation Procedure can be used to load a new PSDL/PSWV file on the system in place of totally reinstalling system software. If there are concerns about system downtime in regards to performing software upgrades in cases where only a new PSDL/PSWV file is needed, this process allows the replacement of the PSDL/PSWV file only. For detailed information on the PSDL installation procedure, refer to *Communication Server 1000S: Upgrade Procedures (NN43031-458)* ().

Dynamic PSDL installation

The system supports Dynamic PSDL installation. It is no longer necessary to update all PSDL files to obtain the latest firmware. A loadware patch with new PSWV can be installed. The patch installation replaces the existing PSWV file and rebuilds the PSDL file. The new M3900 firmware files are available through the Enterprise Solutions PEP Library (ESPL) website.

Four new pdt commands support the Dynamic PSDL feature:

- `lwload <loadware patch filename(s)>`
 - loads one or more loadware patches on the switch.
- `lwinst <loadware patch number(s)>`
 - rebuilds psdl.rec to include new loadware

- `lwout <loadware patch number(s)>`
 - removes one or more loadware patches from the switch
- `lwstat <loadware patch number(s)>`
 - displays status of loadware patches on switch
 - if no patch numbers given, displays all patches

The loadware patches must be located in the `/u/loadware` directory. Below is the example of loadware patching.

```
pdt> lwload ger1ba50.p
Loading loadware patch from "c:/u/loadware/ger1ba50.p"
Loadware patch number is 0.
```

```
pdt> lwinst 0
The existing c:/p/sl1/psdl.rec will be deleted
Do you wish to back up this file (y/n)? [n]

Loadware "GER1BA49" will be replaced by "GER1BA50"
Do you wish to continue (y/n) [y]
```

Building system loadware. This will take a few minutes.

...
Done. Must reboot for changes to take effect.

```
pdt> lwstat 0
Base loadware version: 56
Number of patches installed: 1
Loadware patch number: 0
Patch file: c:/u/loadware/ger1ba50.p
Patchname: GER1 L/w
Ref. number: mplr12345
PRS number: mp12345
Engineer: DE
Created: Mon Feb 5 10:47:25 2001
Patch is loaded & installed
Install date: Mon Feb 5 11:15:20 2001
```

```
pdt> lwout 0
Loadware patch 0 has been removed successfully.
System loadware must now be re-built.
```

Detailed Flash Download procedure

Step	Action
1	Identify telephones to be downloaded. If possible, organize by Telephone type, TN Range, or DN Range. To determine telephone quantity and type, use LDs 97 and 32 to print the ranges of telephones using the commands given below.
2	Establish telephone quantity.
3	<p>Estimate the time required for download. Downloading telephones with the North America reduced language set file takes nine minutes per telephones (on the M3905 it takes 12 minutes). Language sets other than the North America reduced language set file take 12 minutes to download. On Small Systems, you can download four sets in parallel. On Large Systems, you can download one set per XPEC in parallel, up to a maximum of 8 on CP4 and 31 on CPP.</p> <p>The following formulas provide estimates of download times:</p> <ul style="list-style-type: none"> • Small System — North American 6 Language file: $((\text{Quantity of M3902, 3, 4} \times 9 \text{ minutes}) + (\text{quantity of M3905} \times 12 \text{ minutes})) / 4$, where 4 details the number of sets that can be downloaded in parallel. • Small System — Global 10 Language file: $(\text{Quantity of M3902, 3, 4, 5} \times 12 \text{ minutes}) / 4$, where 4 details the number of sets that can be downloaded in parallel • Large System — North America 6 Language file: $((\text{Quantity of M3902,3,4} \times 9 \text{ minutes}) + (\text{quantity of M3905} \times 12 \text{ minutes})) / \text{number of XPECs}$ (assuming even distribution of sets) • Large System — Global 10 Language file: $((\text{Quantity of M3902,3,4,5} \times 12 \text{ minutes})) / \text{number of XPECs}$ (assuming even distribution of sets)
4	<p>Based on the quantity of telephones and the site situation, determine how the download will occur:</p> <ol style="list-style-type: none"> Individual downloads (Use individual commands in LD 32) System download (Use system download command in LD 32) Scheduled download/range download (Use scheduled download commands in LD 32 and LD 97)
5	Issue the appropriate download command.
6	<p>As the download occurs, the telephone displays the following information:</p> <p>During a flash download, the M3902, M3903, and M3905 telephones display messages on the displays at the right. (See</p>

Figure 42 "Information displayed during a flash download" (page 209) on Figure 42 "Information displayed during a flash download" (page 209)) Display 1 shows the "Erasing Flash Memory" message along with blocks written to the second line (each with decreasing contrast). This is followed by Display 2 that reads "Awaiting Download." Display 3 flashes the text "Downloading Firmware" on the first line with progress bars on the second line.

When all 24 segments of the progress bars are displayed as shown, the download is complete. The telephone then resets and returns to service. All user-controlled parameters, such as screen contrast, volume settings, and key labels are not affected by the firmware download. In the event that the firmware download was not successful, the text "Terminal Out of Service" is displayed on the first line. In some cases, the telephone erases the flash memory, showing Display 1 followed by Display 2.

Figure 42
Information displayed during a flash download

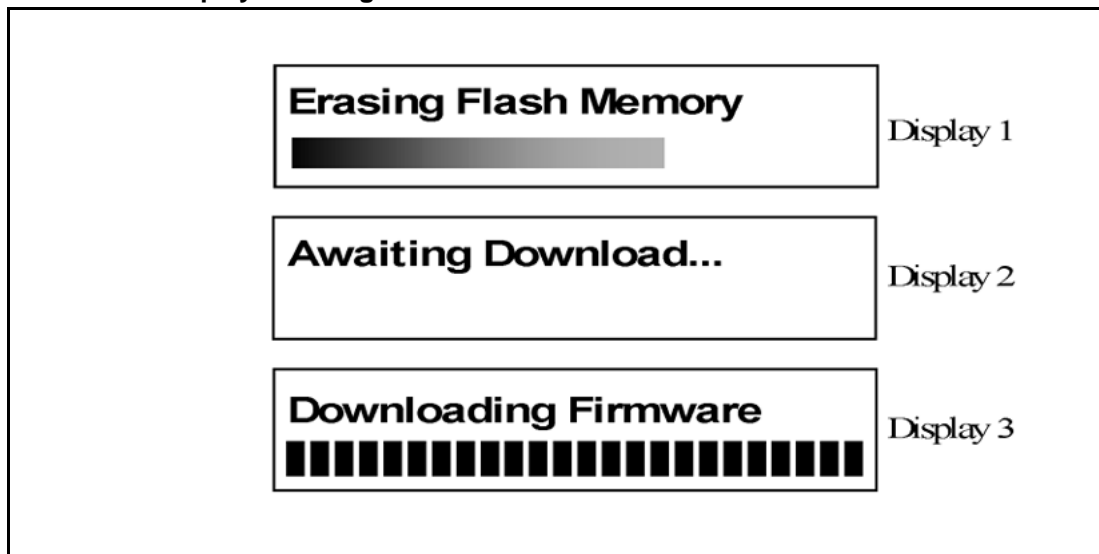

For the M3904, an hourglass icon is displayed during the flash memory erase process (see [Figure 43 "Hourglass icon" \(page 209\)](#)). The erase process can take up to 15 seconds.

Figure 43
Hourglass icon

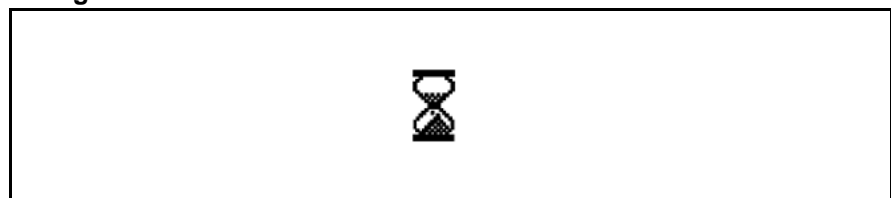

After a successful memory erase, an icon showing a stack of disks (left side of the display) and a phone icon (right side of

the display) are displayed (see [Figure 44 "Stack of disks and telephone icons" \(page 210\)](#)). These icons remain on the display during the entire download.

Figure 44
Stack of disks and telephone icons



Upon receiving the first flash data packet, a page status bar is displayed (see [Figure 45 "Status bar" \(page 210\)](#)). Depending on the language files being downloaded, there are three or four memory pages that are downloaded (three for North American, four for Global, Eastern/Western European versions). As additional flash data packets are received, the status bar advances to the right until the current page is completely programmed.

Once the next page starts to download, a new page block is displayed and the status bar starts from the left again. This process is repeated for the remaining pages. If the download was unsuccessful, the telephone displays a telephone icon with an X through it. This indicates that the flash memory is not programmed (or is corrupt) and a new download must be initiated.

Figure 45
Status bar

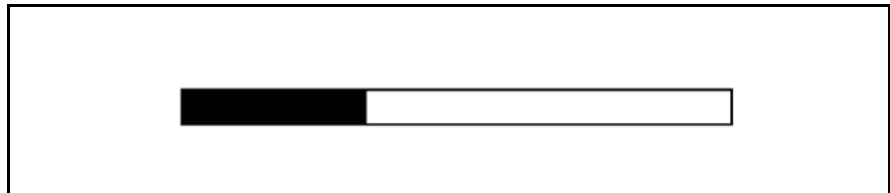

Upon completion of the flash download (all 3/4 pages have been received), the telephone verifies the flash memory contents before displaying the IDLE screen. The IDLE screen consists of the Date (Jan. 1 12:00am) and the brandline (Nortel or customer programmed logo). Up to 25 seconds later, the switch downloads all the parameters to the telephone and the IDLE screen is updated according to the switch settings (for example, soft keys are shown, date is updated, and soft label keys are shown).

- 7 As the download occurs, various messages can appear on the system terminal. A complete list of these messages is in *Software Input Output Reference - System Messages (NN43001-712)* ().

For each telephone that downloads successfully, the following will print:

SDL000 hw a v m

where hw = telephone type, a = Terminal Number (TN),
v = version, m = Mode.

For each telephone that fails to download, the following will print:

SDL2110 e hw a v m

where e = reason code, hw = telephone type, a = TN, v
= version, m = Mode.

For example:

**SDL2110 REASON 21, 3903(40 0 4 6), VERSION 84,
BKGD MODE**

e (reason code, cause of the error) can be:

- 1 = Time-out error
- 2 = PSW checksum error
- 3 = Record checksum error
- 4 = Record format error
- 5 = Firmware state error
- 6 = Invalid page number received
- 7 = Unrequired page delivered during download
- 18 = Flash memory cannot be erased
- 19 = Error detected while programming flash
- 20 = An application is currently active, download cannot proceed
- 21 = Verification byte incorrect

hw (telephone type) can be:

390x (M3900 telephone model: one of 3902, 3903, 3904,
3905)

a (address — TN) can be:

M390x telephone TN (LSCU: loop, shelf, card, unit)

v is the PSW version

m (Mode) scan be:

FAST MODE (from initialization)

MAINT MODE (by ENLL command in LD 30)

BKGD MODE (second attempt after initialization from background program)

--End--

Procedure notes:

- For Symposium Call Center Server (SCCS) sites, you do not have to de-acquire telephones from the SCCS (pulled out of all queues); however, the statistics might not be valid.
- To downgrade an M3900 telephone from Release 2 firmware to Release 1 firmware, or to change the language file from North American to another language file (or vice versa) use PSWV File #5 from [Table 61 "Firmware and PSWV versions" \(page 218\)](#).
- For the downgrades procedure and language changes, refer to the appropriate upgrade procedures NTP:
 - *Communication Server 1000M and Meridian 1 Large System Upgrades Overview (NN43021-458) ()*
 - *Communication Server 1000M and Meridian 1 Small System Software Upgrade (NN43011-459) ()*
 - *Communication Server 1000S: Upgrade Procedures (NN43031-458) ()*
 - *Communication Server 1000E: Upgrade Procedures (NN43041-458) ()*

Configuration parameters in LD 32

To use the Flash Download capability, load LD 32 and issue the following commands.

Single-Set Flash Download

Flash DownLoad Unit (FDLU) - Initiate flash download for this unit. For this command to work, the telephone must be in an idle state. That is, there can be no active call, no active application, and the telephone must be configured and in working condition (responding to a query command). Also, the firmware version on the telephone must not be current. That is, it must be different from the one on the system disk.

. FDLU l s c u

l = loop address
s = shelf address
c = card address
u = unit address

Flash DownLoad Idle (FDLI) - Initiate flash download as soon as the telephone is idle. For this command to work, the telephone must be in working condition. If the telephone is idle, the downloading occurs immediately. If the telephone is on an active call, downloading occurs immediately after the call is terminated. However, if after the active call is terminated, there is an active application on the telephone, downloading is aborted. Again, the downloading operation occurs only if the version on the telephone is not current.

. FDLI l s c u

Flash DownLoad Forced (FDLF) - Initiate flash download immediately. For this command to work, the telephone must be in working condition. If the telephone is idle, the downloading occurs immediately. If the telephone is on an active call, the call is force disconnected and then downloading occurs immediately after the disconnect. It also force downloads the system disk version even if the telephone firmware version is more current. However, if there is an application active on the telephone, the downloading operation is aborted.

. FDLF l s c u

System-wide Flash Download

To prepare and trigger the flash download for the whole system manually, access LD 32 and issue the following commands.

Flash Download System (FDLS) - Initiate system-wide flash download based on the parameters specified in LD 97. This initiates the system-wide flash download to all, or the specified type of M3900 telephones, from the system disk if the flash firmware version on the telephone is different from the version found on the disk.

During system-wide flash download, when flash download detects that an M3900 telephone is in an active call connection, the telephone is skipped. Download logic keeps track of skipped telephones, and comes back to attempt the download later.

M3900 flash download attempts download to each telephone up to three times. If download does not succeed by the third attempt (whether due to an active call connection or some problem such as a transmission error), flash download to the telephone is considered to have failed. An appropriate message is displayed for each telephone that fails

the firmware upgrade process. Upon completion of system-wide flash download, a completion message is displayed on the maintenance telephone. This operation can take up to several days to complete depending on the traffic load, the total number and distribution of the equipped M3900 telephones, and the scheduling of the download. See [Table 59 "Estimated Flash Download times" \(page 214\)](#) for estimations on download times.

When M3900 telephones fail system-wide flash download, you can then determine the cause of the failure, perform corrective action, and repeat the flash download command – system-wide or for a specific telephone.

.FDLS

Flash Download Cancel (FDLC) - Cancel the system-wide flash download. From LD 32 or outside of the overlays, you can cancel or stop the system-wide flash download operation gracefully by issuing the FDLC command. A download in progress to the current telephone(s) completes before the download process terminates.

.FDLC

[Table 59 "Estimated Flash Download times" \(page 214\)](#) shows the estimated Flash Download times.

Table 59
Estimated Flash Download times

System	Average Lines	M3900 Lines	Download Time 10 languages	Faster Download 6 languages
Small System	100	80 (100%)	4 hours	3 hours
Single Group	400	200 (~60%)	20hrs. (2 XPECs) 10hrs. (4 XPECs)	15 hours 7.5 hours
Multi Group	1350	650 (~60%)	22 hrs. (6 XPECs)	16.5
MSL-100	8000	4800 (~60%)	30 hrs. (32 XPECs) 20 hrs. (48 XPECs)	22.5 hours 15 hours

The following assumptions apply to [Table 59 "Estimated Flash Download times" \(page 214\)](#):

- 20% trunking on all systems
- 100% M3900 telephones on Small Systems
- 60% M3900 telephones on Large Systems
- The Faster Download is based on using the North American language files for the M3902, M3903, and M3904 (PSWV File #4 is shown in [Table 61 "Firmware and PSWV versions" \(page 218\)](#)), which are 25% smaller than the Global language files. Therefore, they take 25% less time to download. The languages that are missing from the North American reduced language file are: Swedish, Italian, Norwegian, and Finnish. The languages contained in the North America reduced language file are: English, French, German, Spanish, Brazilian Portuguese, and Japanese Katakana.

Commands for LD 32 are shown below.

Table 60
LD 32, Flash Download commands

Command	Description
FDLU l s c u	Initiate conditional download to one telephone. Terminal number, where: l = loop, s = shelf, c = card, u = unit
FDLI l s c u	Initiate conditional download to an M3900 Series telephone when it becomes idle.
FDLF l s c u	Initiate a forced download to an M3900 Series telephone regardless of its version and state.
FWVU l s c u	Query and print the firmware versions currently on an M3900 Series telephone.
FDLS	Initiate system-wide Flash Download to all, or a specified type of M3900 Series telephones, based on parameters specified in LD 97.
FDLC	Cancel or gracefully stop the system-wide flash download for M3900 Series telephones.

Table 60
LD 32, Flash Download commands (cont'd.)

Command	Description
FSUM	<p>Display the summary report of current firmware versions on all M3900 Series telephones.</p> <p>The format of the report is as follows:</p> <pre> ** M390x SUMMARY REPORT ** dd - ON DISK ff (cc) - nnnn SETS FOUND ff (cc) - nnnn SETS FOUND </pre> <p>Where:</p> <p>x = 2 to 5 for M3902 to M3905 dd = the flash firmware version found on the system disk ff = the downloadable flash firmware version found on the telephones cc = the core firmware found on the telephones nnnn = the number of telephones found with firmware version ff (cc)</p>
FSUM ALL	<p>Display a complete report on all M3900 series telephones based on parameters specified in LD 97.</p> <p>The format of the report is as follows:</p> <pre> TYPE: tttt CUST: cc PDN: ddddddd TN: l s c u FW: vv </pre> <p>Where:</p> <p>tttt = 3902, 3903, 3904 or 3905 cc = 0-99 ddddddd = the Primary DN of the telephone vv = the flash firmware version</p>

Print Firmware Versions on M3900 Telephones

To determine the firmware version information on M3900 telephones, use the following commands in LD 32:

Firmware Version on Unit (FWVU) - Print current firmware versions on the unit. You can query and print the firmware versions (downloadable flash firmware, as well as core firmware) currently on the specified telephone using this command. See [Table 61 "Firmware and PSWV versions" \(page 218\)](#) for a list of current firmware versions.

. FVVU l s c u

Firmware version SUMmary (FSUM) - Print the firmware version summary report for all the M3900 telephones. This command prints the M3900 firmware versions found on the system disk and lists every version together with a count of M3900 telephones that are found to have this version.

.FSUM

The format of the report is as follows:

```
**M390x SUMMARY REPORT**
dd - ON DISK
ff (cc) - nnnn SETS FOUND
ff (cc) - nnnn SETS FOUND
```

where

x = 2 to 5 for M3902 to M3905

dd = the flash firmware version found on the system disk

ff = the downloadable flash firmware version found on the telephones

cc = the core firmware found on the telephones

nnnn = the number of telephones found with firmware version ff (cc)

Firmware version SUMmary ALL (FSUM ALL) – Displays a complete report on all M3900 Series telephones based on the parameters in LD 97.

.FSUM ALL

The format of the report is as follows:

```
TYPE: ttt CUST: cc PDN: ddddddd TN: l s c u FW: vv
```

where

tttt = 3902, 3903, 3904, 3905

cc = 0-99

ddddddd = the Primary DN of the telephone

vv = the flash firmware version

Query Disk Firmware Versions

To determine the firmware version residing on the system disk(s) available for download to the M3900 telephones, use the PSWV command in LD 22 to print the firmware versions for M3900 telephones. See [Table 61 "Firmware and PSWV versions" \(page 218\)](#) for a list of current firmware versions.

Table 61
Firmware and PSWV versions

PEC codes	PSWV codes				F/W codes	
	2	3	4	5	6	7
M3900 telephone (## = 66, 70) XX = See Note 1	PSWV File	PSWV Region	M1 F/W file (PSWV) See Note 2	LD 22 Response for PSWV See Note 3	Set F/W Diagnostic See Note 4	LD 32 FWVU Response for telephone F/W See Note 5
M3902						
NTMN32X X-##	PSWV File #1	Global (10 lang.)	3902.loadaa 84	M3902: S/W VERSION NUMBERS: 84	Lang: L1.9 F/W Ver: 8.4	FLASH FIRMWARE VERSION = 084
	PSWV File #4	N. America (6 lang.)	3902.loadda 84	M3902: S/W VERSION NUMBERS: 84	Lang: L4.9 F/W Ver: 8.4	FLASH FIRMWARE VERSION = 084
M3903						
NTMN33X X-##	PSWV File #1	Global R2: (10 lang.)	3903.loadaa 87	M3903: S/W VERSION NUMBERS: 84	Lang: L1.9 F/W Ver 8.7	FLASH FIRMWARE VERSION = 087
	PSWV File #4	N. America R2 (6 lang.)	3903.loadda 87	M3903: S/W VERSION NUMBERS: 87	Lang: L4.9 F/W Ver 8.7	FLASH FIRMWARE VERSION = 087

Table 61
Firmware and PSWV versions (cont'd.)

1 PEC codes	PSWV codes				F/W codes	
	2	3	4	5	6	7
NTMN33X X-##	PSWV File #5	Rel. 1 for X11 Rel 24	3903.loadaa 36	M3903: S/W VE RSION NUMBERS: 36	Lang: P1.9 F/W Ver 3.6	FLASH FIRMWARE VERSION = 036
M3904						
NTMN34X X-##	PSWV File #1	Global R2: (10 lang.)	3904.loadaa 89	M3904: S/W VE RSION NUMBERS: 89	Flash: 8.9 P0 L1.8	FLASH FIRMWARE VERSION = 089
	PSWV File #4	N. America R2 (6 lang.)	3904.loadaa 89	M3904: S/W VE RSION NUMBERS: 89	Flash: 8.9 P0 L4.8	FLASH FIRMWARE VERSION = 089
NTMN34X X-##	PSWV File #5	Rel. 1 for X11 Rel 24	3904.loadaa 34	M3904: S/W VE RSION NUMBERS: 34	Flash: 3.4 P0 L1.8	FLASH FIRMWARE VERSION = 034
M3905						
NTMN35X X-##	PSWV File #1	Global (10 lang.)	3905.loadaa 89	M3905: S/W VE RSION NUMBERS: 89	Lang: L1.9 F/W Ver 8.9	FLASH FIRMWARE VERSION = 089
	PSWV File #4	N. America (10 lang.)	3905.loadaa 89	M3905: S/W VE RSION NUMBERS: 89	Lang: L1.9 F/W Ver 8.9	FLASH FIRMWARE VERSION = 089

The following notes apply to [Table 61 "Firmware and PSWV versions"](#) (page 218).

Note 1: For Column 1 labeled *M3900 Telephone*, XX is a two-letter alpha character that is part of the product code. For instance, a product code of NTMN32AB is a later issue than a code of NTMN32AA. Release 1 M3900 telephones all started with a "BA" designation for U.S. and Canada telephones, and "AA" for Canada only icon sets. Release

2 M3900 telephones all started with a "FA" designation for U.S. and Canada telephones and "EA" for Canada only icon sets.

Note 2: For Column 4 labeled *M1 F/W File*, the two-letter alpha character followed by two numbers (format: 390x.loadxx##) shows the release level of the PSWV file. For instance, M3902.loadaa40 is a later issue than M3902.loadaa36. The most up-to-date file names are shown.

Note 3: For Column 5 labeled *LD 22 Response for PSWV*, the two number code is the firmware version release level. The larger the number, the newer the version. The last two digits correspond to the same version number as the M3900 firmware version. For instance, M3903: S/W VERSION NUMBERS: 51 is equivalent to M3900 F/W Version 5.1. The most current versions are shown.

Note 4: Column 6, labeled *Set F/W Diagnostic*, shows the language file in use and the firmware level of the set, as seen on an M3900 display. The larger the number, the newer the version. The latest versions are shown. To view the firmware level of an M3900 telephone, press the Options key, scroll to the Display Diagnostics entry, and press Select. Use the Down Navigation key to get to the screen that shows the language file and firmware version.

Note 5: For Column 7 labeled *LD 32 FWVU Response for Telephone F/W*, the three-digit number shows the firmware version of the telephone. The larger the number, the newer the version. For example, a number of 040, refers to a firmware version of 4.0. The latest versions are shown.

Commands for system-wide Flash Download of M3900 telephones

Table 62

LD 97, Configure parameters for System-wide Flash Download.

Prompt	Response	Description
REQ	CHG	Change Flash Download parameters.
	PRT	Print Flash Download parameters.
TYPE	FDL	Flash Download for M3900 telephones.
FDTP		Enter M3900 telephone type selected for Flash Download.
	3902	M3902 telephone
	3903	M3903 telephone
	3904	M3904 telephone
	3905	M3905 telephone
	ALL	All of the above
	(NONE)	None of the above (default)
FDTM		Time interval restriction for Flash Download.

Table 62
LD 97, Configure parameters for System-wide Flash Download. (cont'd.)

Prompt	Response	Description
FDAY	(NO) YES	Do not change time intervals (default). Proceed to change time intervals.
	d n	<p>Note 1: Flash Download is automatically paused one hour before virtual midnight (see TODR in LD 17) to allow midnight routines to run.</p> <p>Note 2: This option is not applicable to reporting.</p> <p>Enter day and number of time intervals for Flash Download, where:</p> <p>d = day of the week (0-6 for Sunday to Saturday) n = number of time intervals (0-4)</p> <p>To disallow download for the day, enter 0.</p> <p>Day is re-prompted until you enter a Carriage Return, <CR>.</p> <p>Note 1: This prompt appears only if FDTM = YES.</p> <p>Note 2: If two or more intervals are specified, they must be overlapping, non-consecutive, and in order.</p>
FINT	s l	<p>Enter starting hour and length for a time interval, where:</p> <p>s = starting hour (0-23) l = length of interval in hours (1-24)</p> <p>Note: FINT is prompted n time if n is greater than 0.</p>
FTNR	(NO) YES	<p>TN range restriction option for Flash Download.</p> <p>No TN restriction (default) Specify TN range.</p>
FSTN		Starting Terminal Number for Flash Download. Prompt appears only if FTNR = YES.
	l s c u c u	<p>Format for Large System and CS 1000E system, where l = loop, s = shelf, c = card, u = unit.</p> <p>Format for Small System, CS 1000S system, Media Gateway 1000B, and Media Gateway 1000T, where c = card and u = unit.</p>
FETN	l s c u	<p>Ending Terminal Number for Flash Download. Prompt appears only if FTNR = YES.</p> <p>Format for Large System and CS 1000E system, and Media Gateway 1000E, where l = loop, s = shelf, c = card, u = unit.</p>

Table 62
LD 97, Configure parameters for System-wide Flash Download. (cont'd.)

Prompt	Response	Description
FDNR	c u	Format for Small System, CS 1000S system, Media Gateway 1000B, and Media Gateway 1000T, where c = card and u = unit. DN range restriction option for Flash Download.
FDDN	(NO) YES	No DN restriction (default). Specify DN range. Flash Download Prime Directory Number range, where:
FRCE	c d1 d2	c = Customer number (0-99) d1 = starting Prime DN d2 = ending Prime DN Note: Prompt appears only if FDNR = YES.
FVER	(NO) YES	System-wide Flash Download control option. Conditional (default). System-wide Flash Download (using the FDLS command in LD 32) applies only to an M3900 series telephone whose flash firmware version is different from the version currently found on the system disk. Forced. Force System-wide Flash Download to all of the specified M3900 series digital telephones regardless of their current flash firmware versions. Note 1: Use this option with caution. Once the download tree is built (that is, after executing FDLS in LD 32), this option automatically reverts to NO. Note 2: This option is not applicable to reporting.
	0-99	Flash firmware version specified for full report, where: If 0, report all versions (default). Note: This option is applicable to reporting only (through the FSUM ALL command in LD 32).

Digital telephones line engineering

Contents

This section contains information on the following topics:

[“Engineering a telephone line” \(page 223\)](#)

[“Selecting a Loop” \(page 232\)](#)

[“Calculating DC Loop Resistance” \(page 233\)](#)

[“Performing Loop Diagnostic Tests” \(page 234\)](#)

[“Measuring Impulse Noise” \(page 236\)](#)

[“Measuring Background Noise” \(page 237\)](#)

[“Calculating Expected Pulse Loss” \(page 237\)](#)

[“Measuring DC Loop Resistance” \(page 241\)](#)

Engineering a telephone line

Use [Procedure 45 “Engineering a telephone line” \(page 223\)](#) to engineer a digital telephone line.

Procedure 45 Engineering a telephone line

Step	Action
1	<p>Be sure that cable pair selections meet the following requirements:</p> <ul style="list-style-type: none"> • AC signal loss is less than 12 dB at 256 kHz due to all sources. • DC loop resistance is less than 175 ohm. • Minimum loop length (mainframe bulkhead to telephone) is 30 m (100 ft).

- Near-end crosstalk coupling loss is >38 dB at Nyquist frequency of 256 kHz (not an issue for typical 22, 24, and 26 AWG twisted pair cable).
 - No bridge taps are permitted.
 - No loading coils are permitted.
 - Protection devices of the carbon-block and gas-filled type are permitted if the off-state shunting impedance is better than 10 M^{1/2} resistive and less than 0.5 pF capacitive.
- 2 Be sure that the following criteria are met where under-carpet cabling is used:
- Characteristic impedance is at 256 kHz, 100 ± 10 ohm.
 - Insertion loss is at 256 kHz, <4.6 dB/kft.
 - The next pair-to-pair coupling loss is at 256 kHz, >40 dB.
- 3 For a typical system with 22, 24, or 26 AWG standard twisted-pair cable, the requirements translate to the following allowable loops:
- up to 915 m (3000 ft) of 22 or 24 AWG cable
 - up to 640 m (2100 ft) of 26 AWG cable
- 4 If the selected cable pair does not work satisfactorily, select another cable pair as shown in [Figure 46 "Engineer a telephone line" \(page 225\)](#).

--End--

Figure 46
Engineer a telephone line

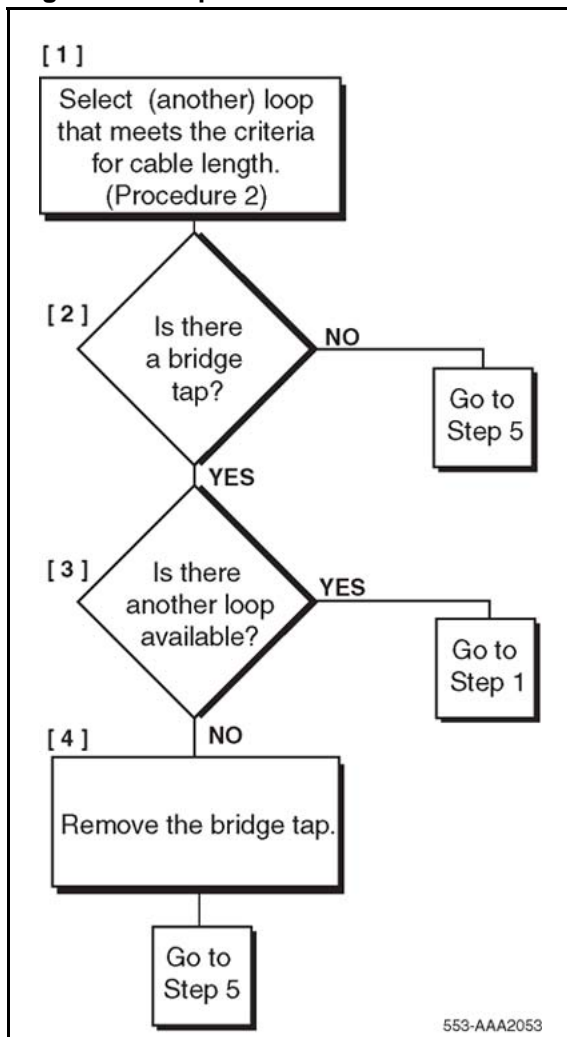

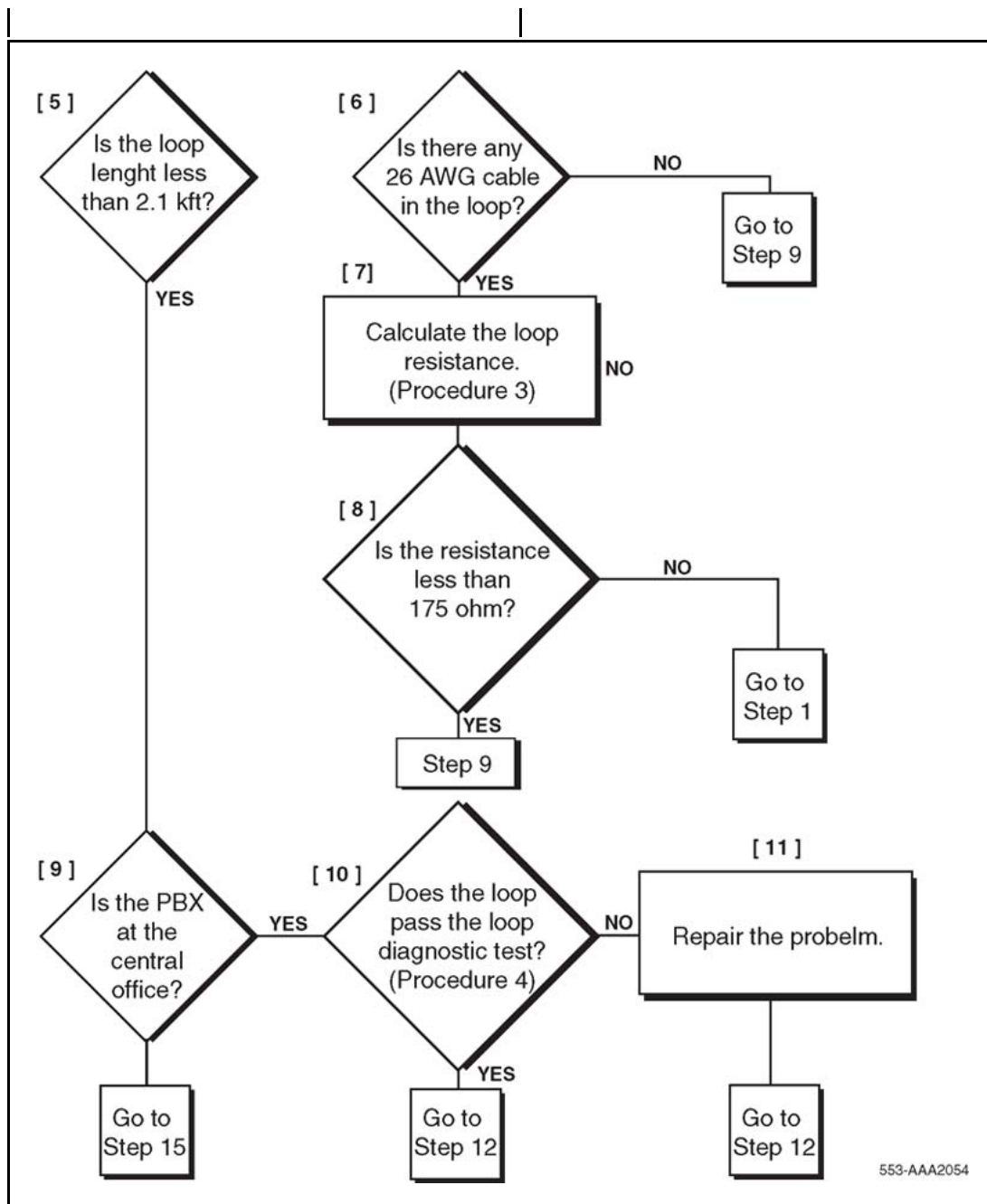

553-AAA2054

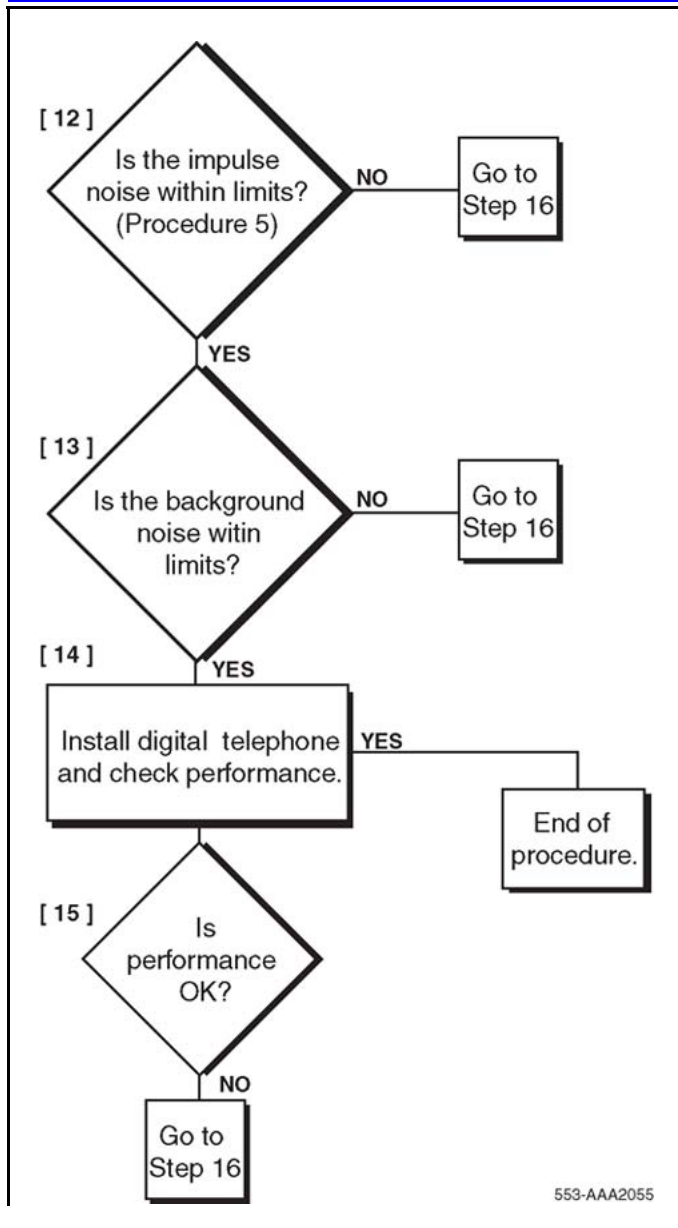

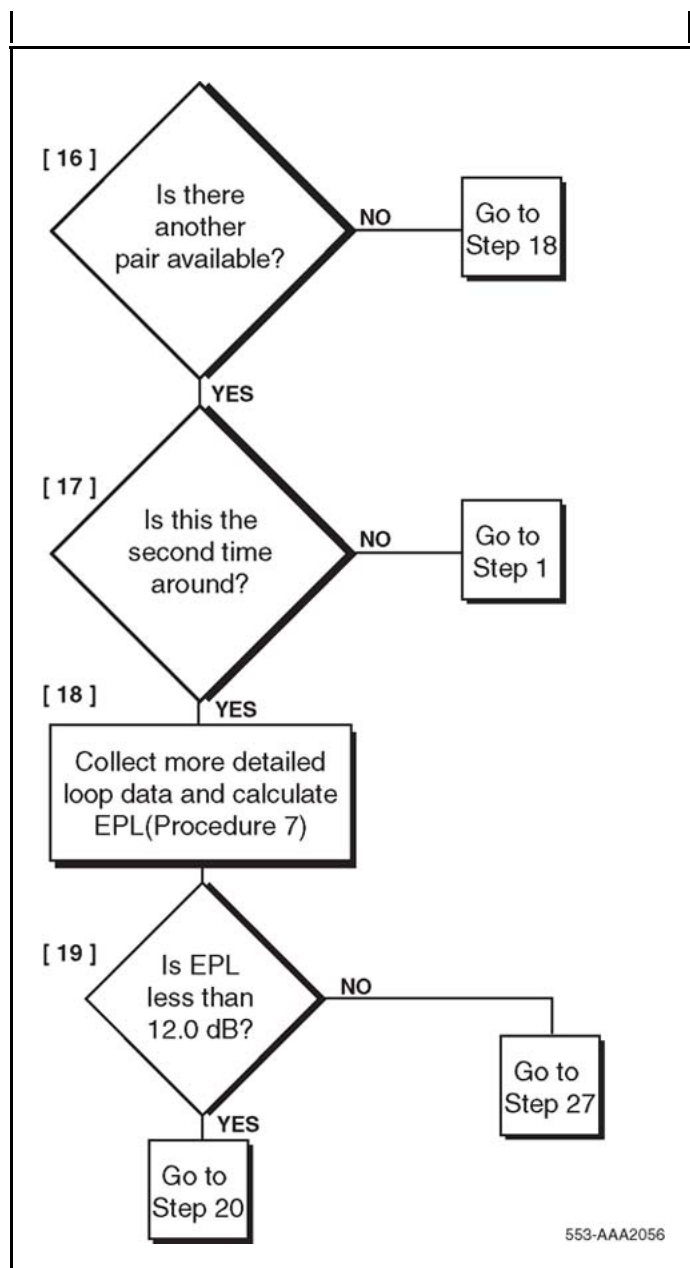

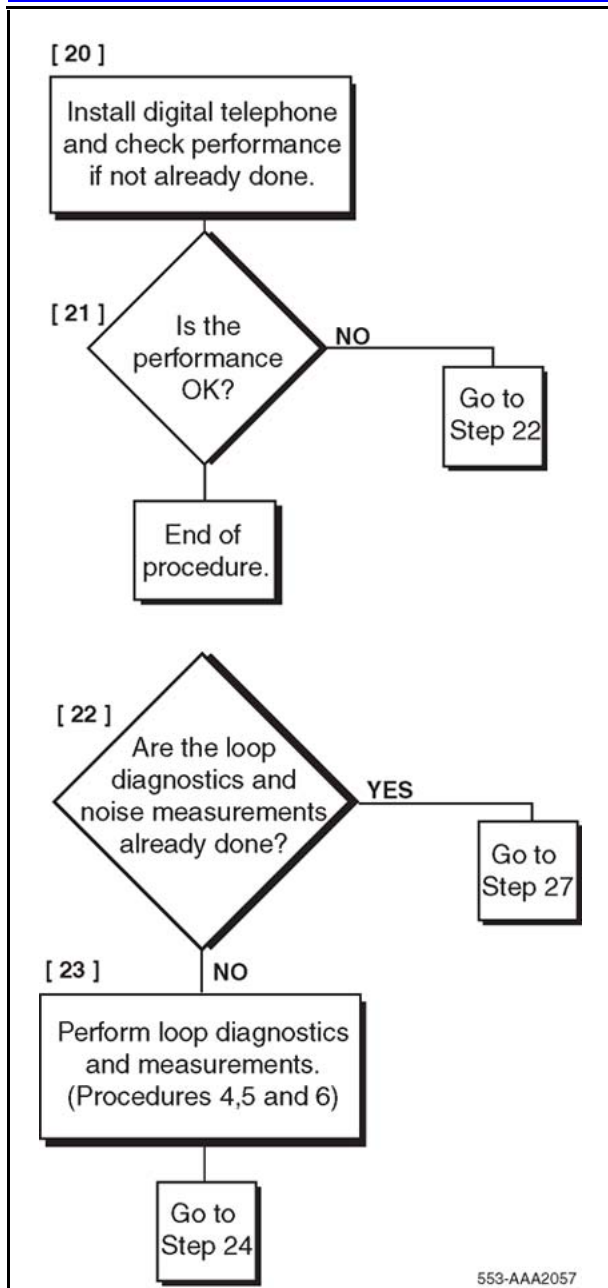

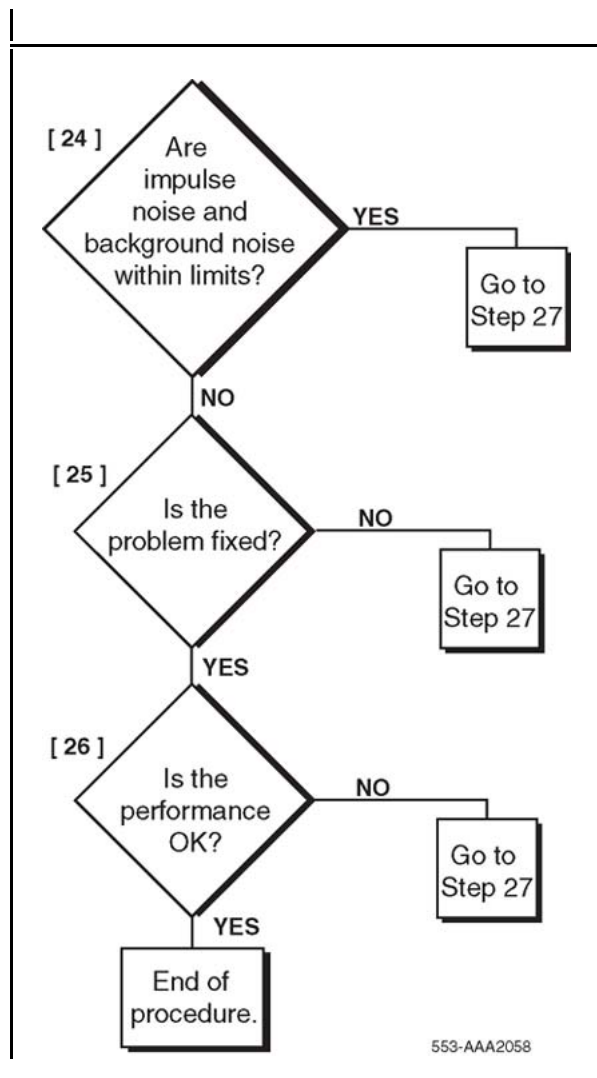

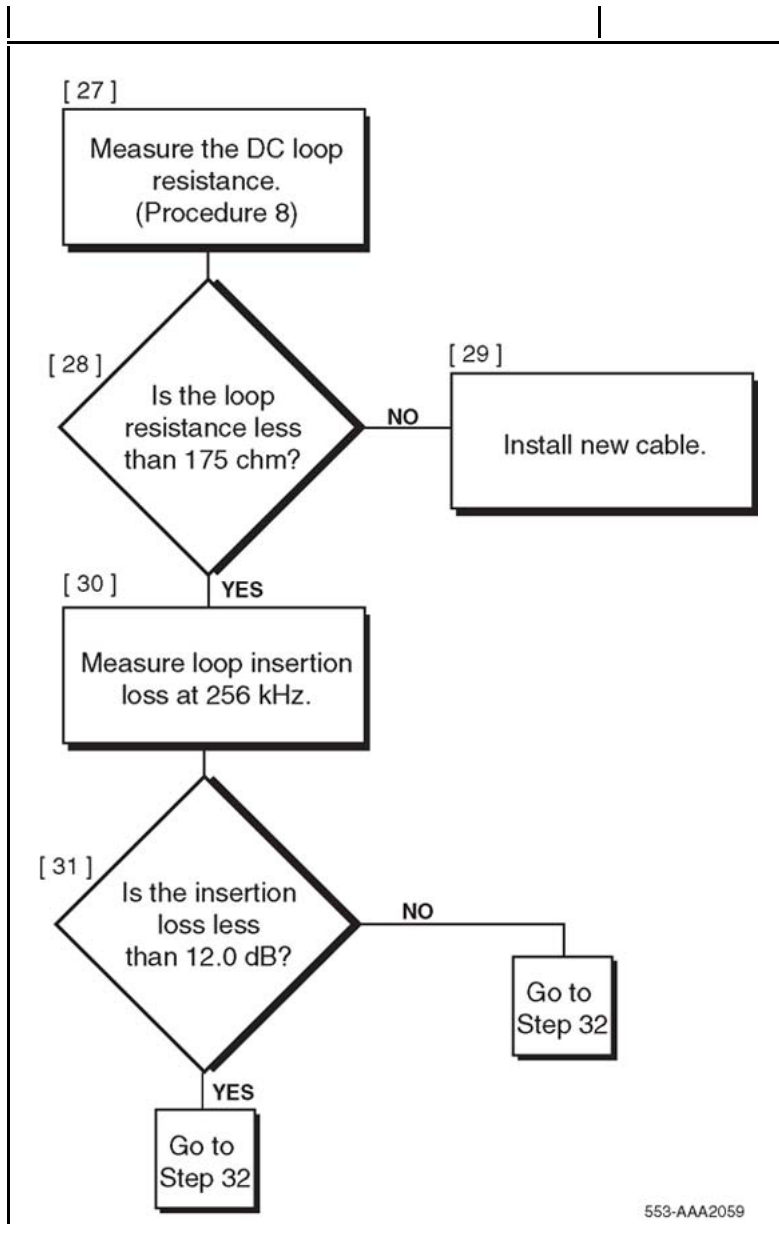

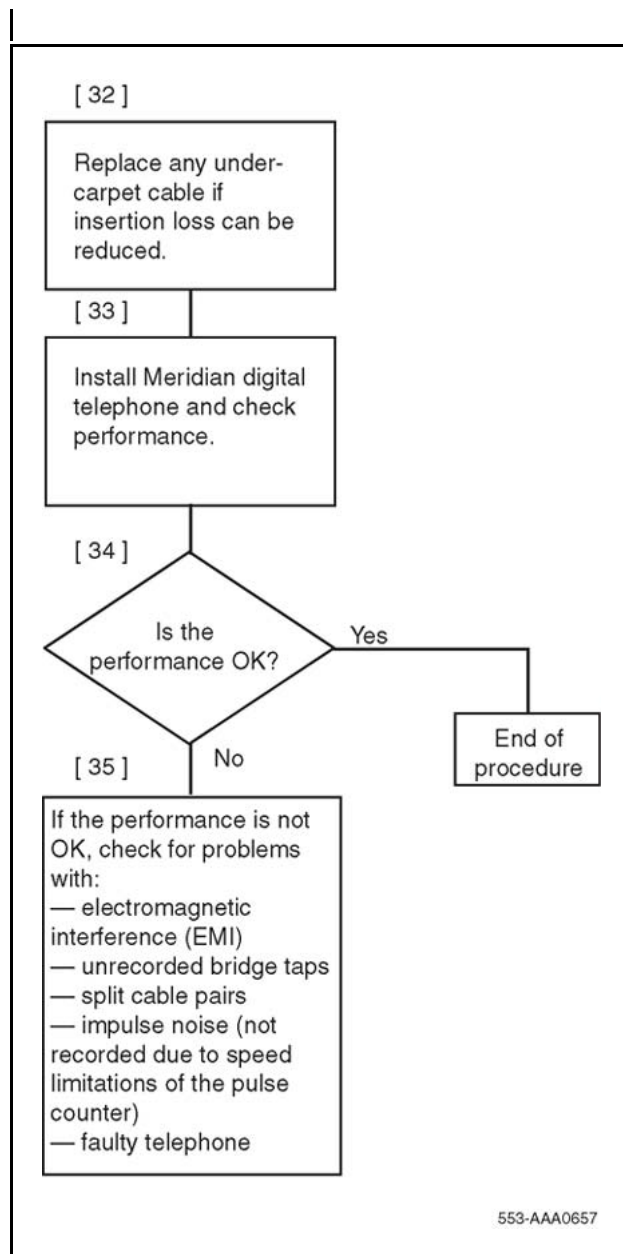

Selecting a Loop

For a Meridian digital telephone, the loop must be without bridge taps, less than 175 ohm DC resistance, and less than 12.0 dB loss at 256 kHz. For single-gauge 22 and 24 AWG cable, and D inside wiring, the length limit is 914.4 m (3000 ft). For single-gauge 26 AWG cable, the length limit is 640.08 m (2100 ft).

The allowable loop length assumes there is no under-carpet cable. If there is under-carpet cable that is a different type than Western Electric (WE) 4-pair cable, reduce the allowable loop length by using the following equation:

$$LM = [12 - (UC \times UL)] / LL$$

where

LM = loop length limit in km (kft) (excluding the length of the under-carpet cable)

LL = loop loss in dB/km (dB/kft) at 256 kHz

UC = length of the under-carpet cable in km (kft)

UL = loss of the under-carpet cable in dB/km (dB/kft) at 256 kHz (see [Table 65 "Attenuation at 256 kHz for U/C cable"](#) (page 240) for dB values)

Calculating DC Loop Resistance

Use [Procedure 46 "Calculating DC loop resistance"](#) (page 233) to calculate the DC loop resistance.

Procedure 46 Calculating DC loop resistance

Step	Action
------	--------

- | | |
|---|----------------------------------------------------------------------------------------------------------------------------------------------------------------------------------------------------------------------------------------------------------------------|
| 1 | Calculate the DC loop resistance by adding the resistance of each cable section. Calculate the resistance of each cable section by using the following formula (cable resistances are given in Table 63 "Conductor resistance per unit" (page 234)): |
|---|----------------------------------------------------------------------------------------------------------------------------------------------------------------------------------------------------------------------------------------------------------------------|

$$LR_i = CR_i \times SL_i$$

where

LR_i = DC resistance for cable section i

CR_i = conductor resistance per unit length for the cable section i

SL_i = length of cable section i

- 2 Add the total of all cable sections. If the total of all sections exceeds 175 ohm, select another loop.

Note: The loop resistance limit of 175 ohm must be reduced by 1 ohm for each percent of the loop that is aerial cable (see [Table 63 "Conductor resistance per unit" \(page 234\)](#)).

--End--

Table 63
Conductor resistance per unit

Gauge	Ohm per loop kft	Ohm per loop km
26	83	278
24	52	173
22	33	109
19	16	54

Performing Loop Diagnostic Tests

The following equipment is required for the loop diagnostic tests in [Procedure 47 "Testing foreign voltage" \(page 234\)](#):

- one volt-ohmmeter (VOM) for each test
- one 77 cable analyzer or equivalent for each test

Procedure 47

Testing foreign voltage

Step	Action
1	Set the VOM range switch to a scale 60 V DC/V AC or greater.
2	Connect the VOM test probes to the loop at the line card or distributing frame.
3	Measure the DC and AC voltage between the following points under no-load conditions: <ul style="list-style-type: none"> • tip (T) and ring (R) • T and ground (GND) • R and GND

Requirement: Voltage readings should be less than 1 V DC/V AC.

--End--

Procedure 48
Testing insulation resistance

Step	Action
1	Set the VOM range switch to ohm x 10,000 and adjust the meter to zero.
2	Connect the VOM test probes to the loop at the line card or distribution frame.
3	Measure the resistance between the following points under no-load conditions: <ul style="list-style-type: none"> • T and R • T and GND • R and GND

Requirement: Resistance readings must be greater than 10 M ohm.

--End--

Procedure 49
Testing DC continuity

Step	Action
1	Short circuit the T and R at the far end.
2	Using the VOM, measure the resistance between the T and R. Requirement: Resistance measurement should be approximately equal to the calculated loop resistance as described in Procedure 46 "Calculating DC loop resistance" (page 233).

--End--

Procedure 50
Testing capacitance unbalance

Step	Action
1	<p>Using the cable analyzer, measure the capacitance between the following points:</p> <ul style="list-style-type: none">• T and GND• R and GND <p>Requirement: The difference between the two readings must be <0.002 μF>.</p>
--End--	

Measuring Impulse Noise

Use [Procedure 51 "Measuring impulse noise" \(page 236\)](#) to measure impulse noise.

Procedure 51 Measuring impulse noise

Step	Action
1	<p>Measure impulse noise on selected lines during busy hours. Use an NE-58B noise measurement set or the equivalent.</p> <p>Note: The termination and weighting filter required are 135 ohm and 100 kHz, respectively, and the blanking interval is 25 μs.</p>
2	<p>Using Figure 47 "Maximum allowable impulse noise counts versus loop loss" (page 238), determine that for a given loop loss and noise threshold the impulse noise counts for each 15-minute interval are below the corresponding curve.</p> <p>Note 1: The values in Figure 47 "Maximum allowable impulse noise counts versus loop loss" (page 238) were derived by assuming that the counter has a count rate of 512 pulses per second.</p> <p>Note 2: Because of the inaccuracy of the noise-measuring set, additional errors can occur during the blanking interval, and the reading consequently is lower than the actual measurement.</p>
--End--	

Measuring Background Noise

Use [Procedure 52 “Measuring background noise” \(page 237\)](#) to measure background noise.

Procedure 52 Measuring background noise

Step	Action
1	Measure background noise on the loop by using an NE-58B noise-measuring set. Note: The weighting and termination to be used are 100 kHz flat and 135 ohm, respectively.
2	Reject the loop being tested if the measured background noise is not less than 51 dBm.
--End--	

Calculating Expected Pulse Loss

Use [Procedure 53 “Calculating expected pulse loss” \(page 238\)](#) to calculate expected pulse loss.

Figure 47
Maximum allowable impulse noise counts versus loop loss

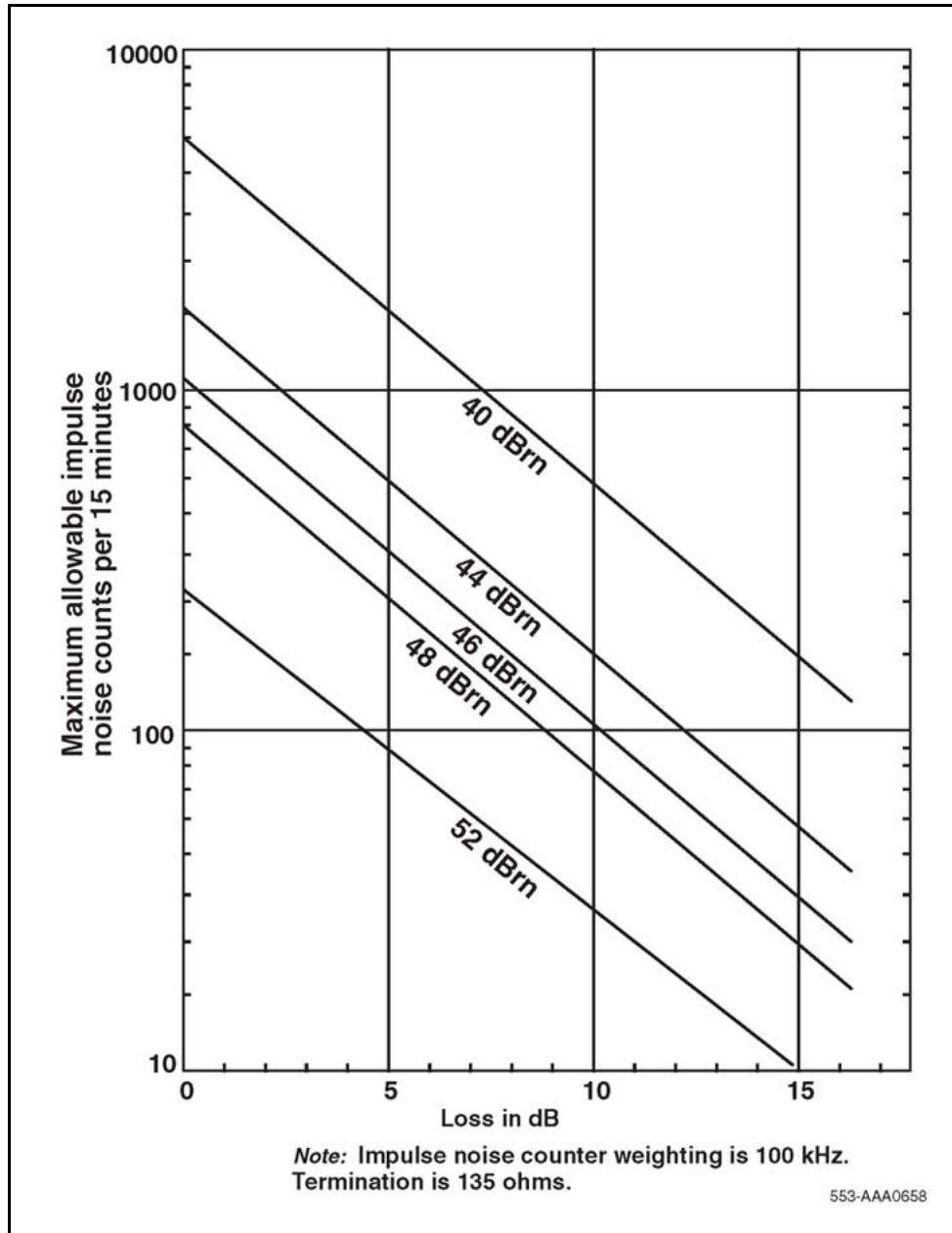

Procedure 53
Calculating expected pulse loss

Step	Action
1	Collect loop makeup data between the line card and the terminal. For each cable section, the data required is:

- cable type (PIC or pulp)
 - gauge
 - length
 - type of plant construction (underground, aerial, or in-building)
- 2 Calculate individual cable section losses by using the figures in [Table 64 "Cable attenuation at 256 kHz and 21.1 degrees C \(70 degrees F\)"](#) (page 240) through [Table 66 "Attenuation at 256 kHz for D inside wiring cable"](#) (page 241), and the following equation:

$$CSLi = SLi \times Li$$

- CSLi = cable section loss for section *i*
 - SLi = section length of section *i*
 - Li = loss per unit length for section *i*
- 3 Correct individual cable section losses for maximum cable temperature by using the following equation:

$$TCLi = CSLi \times TCFi$$

- TCLi = temperature corrected loss for section *i*
- TCFi = temperature correction factor for section *i*

Correction factors:

- aerial cable TCF = 1.1
 - underground cable TCF = 1.04
 - in-building cable TCF = 1
- 4 Determine junction loss (see [Figure 48 "Junction loss versus cable characteristic impedance"](#) (page 241)).

Note: Junction loss due to gauge discontinuity of outside plant cables and D inside wire varies between 0.03 dB and 0.07 dB and can be ignored. However, AMP 25-pair under-carpet wiring has a characteristic impedance of 40 ohm at 256 kHz, and its junction loss is approximately 2 dB. This must be included in the calculation.

- 5 Calculate the expected pulse loss (EPL) by finding the sum of the items.
- 6 Reject loops whose expected pulse loss is greater than 12 dB.

--End--

Example of applying calculation

Example of applying the calculation shown in [Procedure 53 "Calculating expected pulse loss"](#) (page 238)

Section 1:

Mainframe bulkhead to DF1 - 500m, 26 AWG PIC, underground

Section 2:

DF1 to DF2 - 200m, 26 AWG PIC, inside

Section 3:

DF2 to terminal - 24 AWG NT D-inside

Therefore:

SL1 = 1.5 km, SL2 = 0.2 km, SL3 = 0.1 km

From [Table 64 "Cable attenuation at 256 kHz and 21.1 degrees C \(70 degrees F\)"](#) (page 240) and [Table 65 "Attenuation at 256 kHz for U/C cable"](#) (page 240):

L1 = 13.7 dB/km, L2 = 13.7 dB/km, L3 = 13.3 dB/km.

Using the equation in Step 2, we arrive at the following:

CSL1 = 6.85 dB, CSL2 = 2.74 dB, and CSL3 = 1.33 dB

Temperature corrections:

Using correction factors of TCF1 = 1.04, and TCF2 and TCF3 = 1, and using the equation in Step 3 results in TCL1 = 7.12 dB, TLC2 = 2.74 dB, and TCL3 = 1.33 dB.

Expected pulse loss (EPL) value:

Neglecting any junction loss (see the note in Step 4), Step 5 results in an EPL value of TSL1 + TSL2 + TSL3 + 0 = 11.19 dB.

This is under the 12 dB limit and meets the criteria.

Table 64
Cable attenuation at 256 kHz and 21.1 degrees C (70 degrees F)

Cable type	26 AWG		24 AWG		22 AWG		19 AWG	
	dB/kft	dB/km	dB/kft	dB/km	dB/kft	dB/km	dB/kft	dB/km
PIC	4.2	13.7	3.1	10.2	2.5	8.1	1.7	5.6
Pulp	4.3	14.3	3.5	11.4	2.7	9.0	2.0	6.6

Table 65
Attenuation at 256 kHz for U/C cable

WE 4-pair		AMP 25-pair	
dB/kft	dB/km	dB/kft	dB/km
4.6	15.3	19.0	63.3

Table 66
Attenuation at 256 kHz for D inside wiring cable

NT		WE		Superior		General	
dB/kft	dB/km	dB/kft	dB/km	dB/kft	dB/km	dB/kft	dB/km
4.0	13.3	3.2	10.7	3.7	13.3	4.6	15.3

Measuring DC Loop Resistance

Measure DC loop resistance by using standard procedures.

Note: The DC loop resistance limit of 175 ohm should be reduced by 1 ohm for each one percent of the total loop that is aerial cable.

Figure 48
Junction loss versus cable characteristic impedance

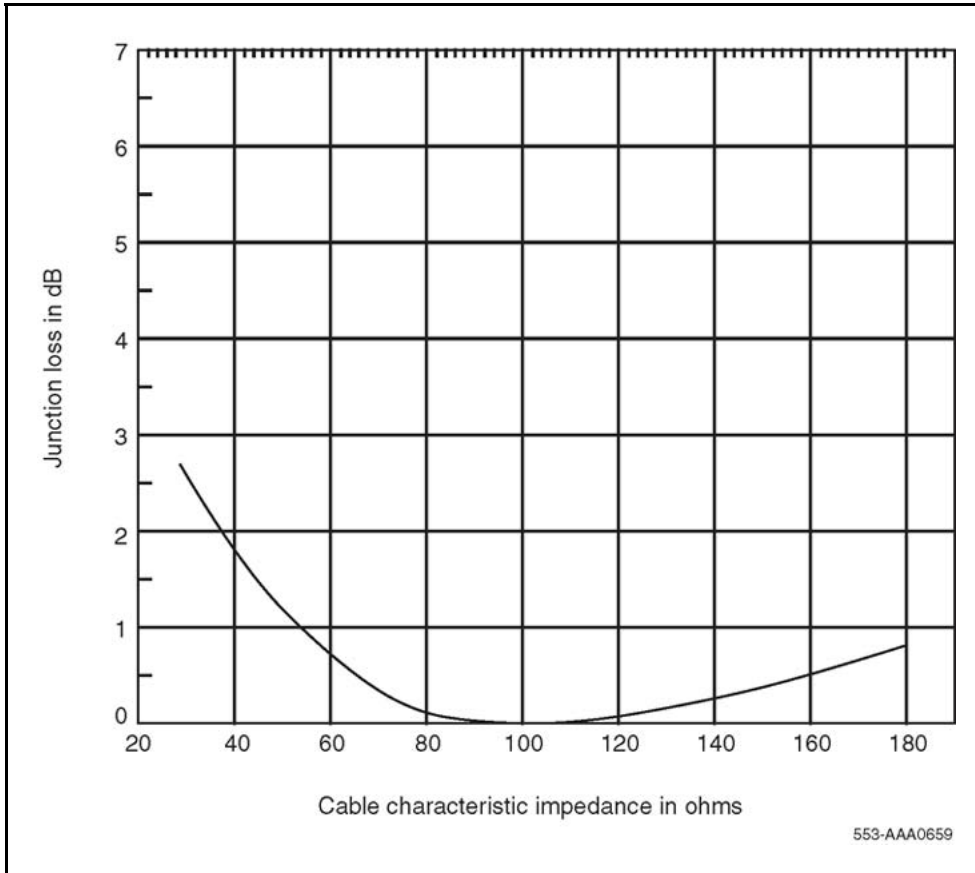

Analog (500/2500-type) telephones

Contents

This section contains information on the following topics:

- “Introduction” (page 243)
- “Installation and removal” (page 243)
 - “Designate 500-type telephones” (page 244)
 - “Designate 2500-type telephones” (page 245)
 - “Connect the telephones” (page 246)
 - “Cross-connect the telephones” (page 247)
 - “Cross-connect the telephones” (page 247)
- “Operation” (page 253)

Introduction

Analog (500/2500-type) telephones are regular telephones not normally associated with a business environment, but they are compatible with the system. They are configured using LD 10. The 500-type telephones have a rotary dial. The 2500-type telephones are the basic push-button models, such as the Link and Unity, which do not have feature buttons normally found on business telephones.

Installation and removal

Follow the steps in [Procedure 54 “Installing an analog \(500/2500-type\) telephone” \(page 243\)](#) to install an analog (500/2500-type) telephone.

Note: Do not remove the circuit card if any remaining units on the card are assigned.

Procedure 54 Installing an analog (500/2500-type) telephone

Step	Action
1	Ensure that the wiring is installed at the telephone’s location.

- 2 Unpack and inspect the telephone for damage. Assemble the handset and line cords if necessary.
- 3 Install the required designations on the telephone.
- 4 Connect the telephone to the TELADAPT connector.
- 5 Cross-connect the telephone wiring at the cross-connect terminal.
- 6 Configure the telephone in the system. Refer to the *Software Input Output Administration (NN43001-611) ()* .

--End--

Follow the steps in [Procedure 55 “Removing an analog \(500/2500-type\) telephone” \(page 244\)](#) to remove an analog (500/2500-type) telephone.

Procedure 55
Removing an analog (500/2500-type) telephone

Step	Action
1	Remove telephone data from the system. Refer to the <i>Software Input Output Administration (NN43001-611) ()</i> .
2	Disconnect the telephone from the TELADAPT connector.
3	Pack the telephone in a container.
4	If necessary, remove the cross-connections for the telephone at the cross-connect terminal.
5	Remove the line circuit card if required. Refer to <i>Circuit Card Reference (NN43001-311) ()</i> .

--End--

Designate 500-type telephones

Follow the steps in [Procedure 56 “Designating 500-type telephones” \(page 244\)](#) to designate analog 500-type telephones:

Procedure 56
Designating 500-type telephones

Step	Action
1	Remove the finger wheel (refer to Procedure 57 “Removing the finger wheel from an analog 500-type telephone” (page 245)).
2	Remove the number card from its envelope.
3	Designate the number card with the appropriate directory number and station designator.

- 4 Insert the number card into the finger wheel (making sure the number card is properly oriented).
- 5 Place the telephone on a flat surface.
- 6 Place the finger wheel over the clamp on the dial, with the "0" hole directly over the digit "9," making sure the finger wheel depressions are properly positioned on the prongs of the clamp plate.
- 7 Rotate the finger wheel counterclockwise until the clamp spring snaps into the notch on the underside of the finger wheel.

--End--

Follow the steps in [Procedure 57 "Removing the finger wheel from an analog 500-type telephone"](#) (page 245) to remove the finger wheel from 500-type telephones.

Procedure 57
Removing the finger wheel from
analog 500-type telephone

Step	Action
1	Place the telephone on a flat surface.
2	Rotate the finger wheel clockwise as far as possible.
3	Insert a paper clip into the small hole between the digits "9" and "0" located on the edge of the grooved section of the finger wheel.
4	Press down on the releaser to disengage the finger wheel clamp spring.
5	Rotate the finger wheel further clockwise until the clamp spring releases.
6	Remove the finger wheel when it becomes loose. The dial returns to normal position.

--End--

Designate 2500-type telephones

Follow the steps in [Procedure 58 "Designating analog 2500-type telephone"](#) (page 246) to designate 2500-type telephones.

Procedure 58
Designating analog 2500-type telephone

Step	Action
1	The designation window is located directly below the dial pad. Insert a paper clip into the hole at the left or right end of the designation window.
2	Gently pry the window toward the center and remove.
3	Insert number tag with the appropriate directory number and station designator, and replace the designation window.

--End--

Connect the telephones

Follow the steps in [Procedure 59 "Connecting analog \(500/2500-type\) telephones" \(page 246\)](#) to connect analog (500/2500-type) telephones.

[Table 67 "NE-500/2500 telephone connections" \(page 247\)](#) lists the NE-500/2500 telephone connections.

Procedure 59
Connecting analog (500/2500-type) telephones

Step	Action
1	Ensure that the terminal connector is compatible with the telephone connector.
2	Connect the telephone mounting cord. TELADAPT cords (NE-625F connector) do not require terminations. Insert the plastic connector on the end of the telephone mounting cord into the NE-625F-type receptacle.
3	Connect the mounting cord to an NE-284-74-5001 Amphenol adapter if re-using a 16- or 25-pair cable. Plug the adapter into the cable connector. Fasten the connector together with the screws provided at the end of each connector.

--End--

Table 67
NE-500/2500 telephone connections

Mounting cord	NE-47QA or QBBIB block designation	NE-284-74-5001 designation	Cable color pairs (16 to 25 not used)	Connect to TN
TIP (green)	G	1T	W-BL	TIP
RING (red)	R	1R	BL-W	RING
GND (yellow)	BK	X2		
	Y	X1		

Cross-connect the telephones

Be sure to connect the telephones as shown in [Figure 49](#) "NE-500/2500-type telephone cross-connections for IPE modules" (page 249). [Figure 49](#) "NE-500/2500-type telephone cross-connections for IPE modules" (page 249) provides the diagram for cross-connecting analog (500/2500-type) telephones on an Intelligent Peripheral Equipment (IPE) module.

[Table 68](#) "500/2500 line card pair-terminations for IPE module connectors A, E, K, R" (page 250), [Table 69](#) "500/2500 line card pair-terminations for IPE module connectors B, F, L, S" (page 250), and [Table 70](#) "500/2500 line card pair-terminations for IPE module connectors C, G, M, T" (page 251) show analog (500/2500-type) telephone cross-connections on an Intelligent Peripheral Equipment (IPE) module.

Follow the steps in [Procedure 60](#) "Cross-connecting the telephones" (page 247) to cross-connect analog (500/2500-type) telephones.

Procedure 60 Cross-connecting the telephones

Step	Action
1	Locate the telephone terminations at the cross-connect terminal. Telephone terminations are located on the vertical side of the frame when frame-mounted blocks are used and in the blue field when wall-mounted blocks are used.
2	Connect Z-type cross-connecting wire to the leads of the telephone. See Table 71 "Z-type cross-connecting wire" (page 252) and Table 72 "Inside wiring colors" (page 252).
3	Locate the line circuit card (TN) terminations. Line circuit card (TN) terminations are located on the horizontal side of the distributing frame when frame-mounted blocks are used and in the white field when wall-mounted blocks are used.

- 4 Run and connect the other end of the cross-connecting wire to the assigned TN terminal block.

--End--

Figure 49
NE-500/2500-type telephone cross-connections for IPE modules

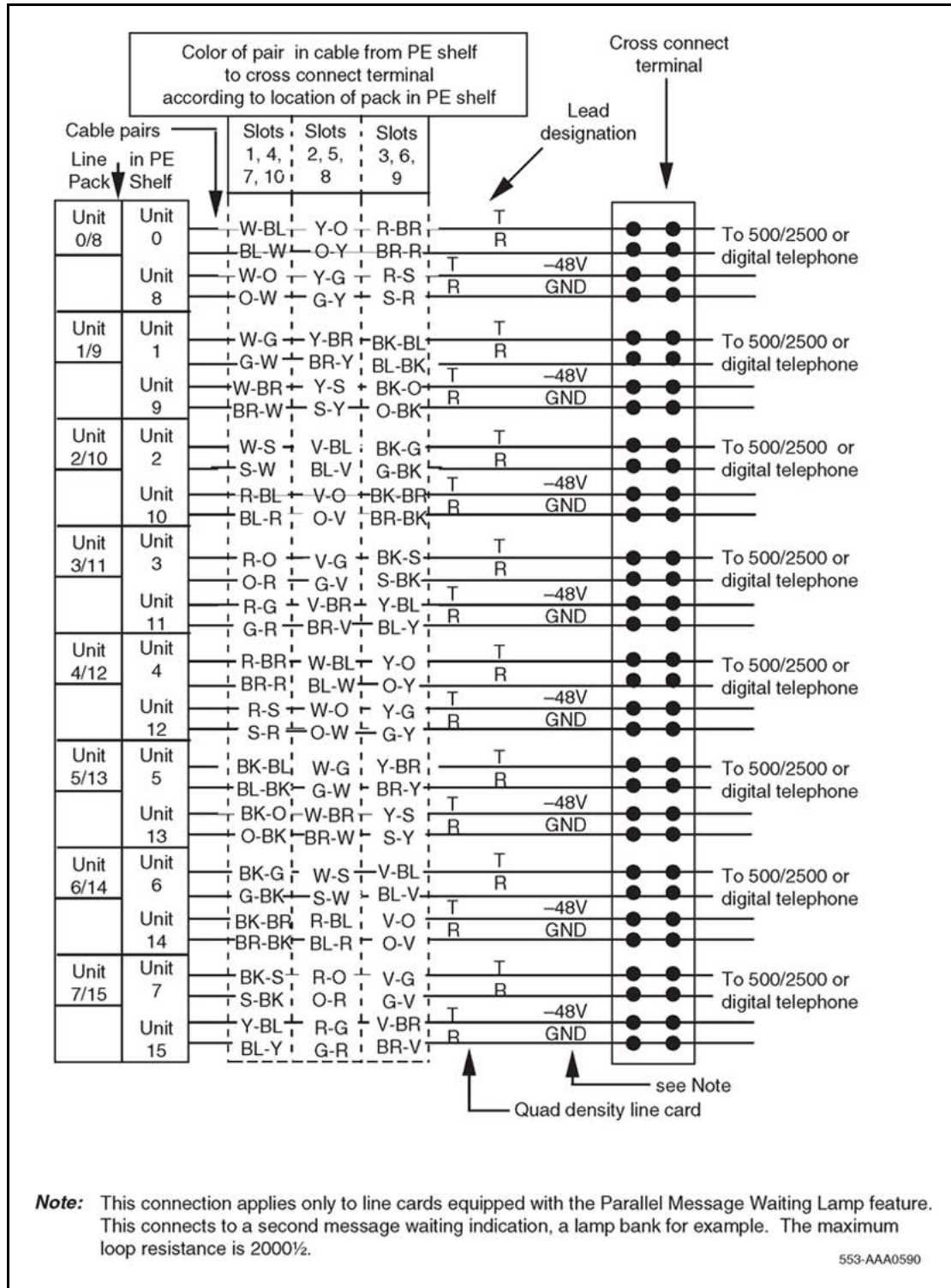

Note: This connection applies only to line cards equipped with the Parallel Message Waiting Lamp feature. This connects to a second message waiting indication, a lamp bank for example. The maximum loop resistance is 2000½.

553-AAA0590

Table 68
500/2500 line card pair-terminations for IPE module connectors A, E, K, R

Pair	Pins	Pair color	I/O panel connectors				Unit
			A	E	K	R	16/card
1T/1R	26/1	W-BL/BL-W	slot 0	slot 4	slot 8	slot 12	0
2T/2R	27/2	W-O/O-W					1
3T/3R	28/3	W-G/G-W					2
4T/4R	29/4	W-BR/BR-W					3
5T/5R	30/5	W-S/S-W					4
6T/6R	31/6	R-BL/BL-R					5
7T/7R	32/7	R-O/O-R					6
8T/8R	33/8	R-G/G-R					7
9T/9R	34/9	R-BR/BR-R					8
10T/10R	35/10	R-S/S-R					9
11T/11R	36/11	BK-BL/BL-BK					10
12T/12R	37/12	BK-O/O-BK					11
13T/13R	38/13	BK-G/G-BK					12
14T/14R	39/14	BK-BR/BR-BK					13
15T/15R	40/15	BK-S/S-BK					14
16T/16R	41/16	Y-BL/BL-Y					15

Table 69
500/2500 line card pair-terminations for IPE module connectors B, F, L, S

Pair	Pins	Pair color	I/O panel connectors				Unit
			B	F	L	S	16/card
1T/1R	26/1	W-BL/BL-W	slot 1	slot 5	slot 9	slot 13	0
2T/2R	27/2	W-O/O-W					1
3T/3R	28/3	W-G/G-W					2
4T/4R	29/4	W-BR/BR-W					3
5T/5R	30/5	W-S/S-W					4
6T/6R	31/6	R-BL/BL-R					5
7T/7R	32/7	R-O/O-R					6
8T/8R	33/8	R-G/G-R					7
9T/9R	34/9	R-BR/BR-R					8
10T/10R	35/10	R-S/S-R					9
11T/11R	36/11	BK-BL/BL-BK					10

Table 69
500/2500 line card pair-terminations for IPE module connectors B, F, L, S (cont'd.)

Pair	Pins	Pair color	I/O panel connectors				Unit
			B	F	L	S	16/card
12T/12R	37/12	BK-O/O-BK					11
13T/13R	38/13	BK-G/G-BK					12
14T/14R	39/14	BK-BR/BR-BK					13
15T/15R	40/15	BK-S/S-BK					14
16T/16R	41/16	Y-BL/BL-Y					15
17T/17R	42/17	Y-O/O-Y	slot 2	slot 6	slot 10	slot 14	0
18T/18R	43/18	Y-G/G-Y					1
19T/19R	44/19	Y-BR/BR-Y					2
20T/20R	45/20	Y-S/S-Y					3
21T/21R	46/21	V-BL/BL-V					4
22T/22R	47/22	V-O/O-V					5
23T/23R	48/23	V-G/G-V					6
24T/24R	49/24	V-BR/BR-V					7
25T/25R	50/25	V-S/S-V					Spare

Table 70
500/2500 line card pair-terminations for IPE module connectors C, G, M, T

Pair	Pins	Pair color	I/O panel connectors				Unit
			C	G	M	T	16/card
1T/1R	26/1	W-BL/BL-W	slot 2	slot 6	slot 10	slot 14	8
2T/2R	27/2	W-O/O-W					9
3T/3R	28/3	W-G/G-W					10
4T/4R	29/4	W-BR/BR-W					11
5T/5R	30/5	W-S/S-W					12
6T/6R	31/6	R-BL/BL-R					13
7T/7R	32/7	R-O/O-R					14
8T/8R	33/8	R-G/G-R					15
9T/9R	34/9	R-BR/BR-R	slot 2	slot 6	slot 11	slot 15	0
10T/10R	35/10	R-S/S-R					1
11T/11R	36/11	BK-BL/BL-BK					2
12T/12R	37/12	BK-O/O-BK					3
13T/13R	38/13	BK-G/G-BK					4

Table 70
500/2500 line card pair-terminations for IPE module connectors C, G, M, T (cont'd.)

Pair	Pins	Pair color	I/O panel connectors				Unit
			C	G	M	T	16/card
14T/14R	39/14	BK-BR/BR-BK					5
15T/15R	40/15	BK-S/S-BK					6
16T/16R	41/16	Y-BL/BL-Y					7
17T/17R	42/17	Y-O/O-Y					8
18T/18R	43/18	Y-G/G-Y					9
19T/19R	44/19	Y-BR/BR-Y					10
20T/20R	45/20	Y-S/S-Y					11
21T/21R	46/21	V-BL/BL-V					12
22T/22R	47/22	V-O/O-V					13
23T/23R	48/23	V-G/G-V					14
24T/24R	49/24	V-BR/BR-V					15
25T/25R	50/25	V-S/S-V					Spare

Table 71
Z-type cross-connecting wire

Size	Gauge	Color	Designation
1 pr	22	Y-BL	Tip
		BL-Y	Ring
3 pr	24	W-BL	Voice T
		BL-W	Voice R
		W-O	Signal T
		O-W	Signal R
		W-G	Power
		G-W	Power

Table 72
Inside wiring colors

Inside wiring colors		Connect to equipment TN
Z station wire	16/25-pair cable	
G	W-BL	First pair Tip

Table 72
Inside wiring colors (cont'd.)

Inside wiring colors		Connect to equipment TN
Z station wire	16/25-pair cable	
R	BL-W	First pair Ring
BK	W-O	Second pair Tip
Y	O-W	Second pair Ring

Operation

Although analog (500/2500-type) telephones do not have feature keys, you can access various system features using Special Prefix (SPRE) codes. SPRE codes are also useful for Meridian 1 proprietary telephones to access features without using feature keys. Dial the SPRE code (unique to each customer within the system) and then the feature code that applies to the operation you desire.

[Table 73 "Feature codes used with SPRE" \(page 253\)](#) lists the feature codes available using SPRE.

Table 73
Feature codes used with SPRE

Dial SPRE +	Operation performed
1	Ring Again
2	Cancel Ring Again
3	Ringing Number, Call Pickup
4	TAFAS (Trunk Answer From Any Station)
5	Charge Account for CDR
6	Authorization Code Access
70 + ACOD + mmm (Trunk Route Access Code and Member)	Trunk Verification From Station
71 + DN	Call Park, To Park
72 + DN	Call Park, To Retrieve
73	System Speed Call, To Use
74	Call Forward activate or cancel (500-type telephones)
75 + Entry Access Code + DN (500-type telephones)	Speed Call, Individual To Program Entry
76 + Entry Access Code (500-type telephones)	Speed Call, Individual To Use Entry

Table 73
Feature codes used with SPRE (cont'd.)

Dial SPRE +	Operation performed
77	Permanent Hold (500-type telephones)
78	Stored Number Redial, To Store
79	Stored Number Redial, To Redial
81	Automatic Set Relocation
83	Malicious Call Trace
84	Integrated Messaging System
86 + x (status)	Room Status
86 + 1	Cleaning Request
86 + 2	Cleaning In Progress
86 + 3	Room Cleaned
86 + 4	Passed Inspection
86 + 5	Failed Inspection
86 + 6	Cleaning Skipped
86 + 7	Not For Sale
87	Disconnect Trunk, Conference 6 (analog (500/2500 type) telephones)
89	Last Number Redial
91	Access to maintenance programs by Maintenance Telephone
92	Terminal Diagnostics, telephones and attendant consoles
93	Conference Circuit Testing
94	Ringing Number, Group Pickup
95	Ringing Number, DN Pickup
96	Centrex Switchhook Flash
97	Unassigned Automatic Call Distribution (ACD) analog (500/2500 type) telephone Log in/out
98	Unassigned ACD analog (500/2500 type) telephone Activate/deactivate Not Ready

Table 74
2500-type telephone features (no SPRE code used)

# + 1 + DN	Call Forward
# + 2 + Speed Call code + DN	Speed Call, Individual, To Program Entry
# + 2 + Speed Call code + *	Speed Call, Individual, To Erase Entry
# + 3 + Speed Call code	Speed Call, Individual, To Use Entry
# + 4	Permanent Hold

Appendix

Meridian Modular Telephones

Contents

This section contains information on the following topics:

- “Introduction” (page 79)
 - “Software requirements” (page 258)
 - “Intelligent Peripheral Equipment requirements” (page 258)
- “General description” (page 258)
- “Physical description” (page 263)
 - “Volume control” (page 264)
 - “Message Waiting lamp” (page 265)
 - “Handsfree/Mute key (M2008HF and M2616 only)” (page 265)
- “Features and options” (page 266)
 - “Display Module” (page 267)
 - “Meridian Programmable Data Adapter” (page 268)
 - “Program key” (page 268)
 - “External Alerter Interface” (page 268)
 - “Key Expansion Module” (page 269)
 - “Brandline Insert” (page 270)
 - “Headset” (page 270)
- “Relocation” (page 272)
- “Specifications” (page 273)
 - “Environmental and safety considerations” (page 273)
 - “Line engineering” (page 274)
 - “Local alerting tones” (page 275)
 - “Power requirements” (page 276)

[“Meridian Programmable Data Adapter” \(page 281\)](#)

[“Handsets” \(page 282\)](#)

Note: This section is for reference only. The Meridian Modular Telephones are manufacture discontinued and no longer available.

Introduction

This chapter provides feature, add-on module, relocation, and specification information for the M2006, M2008, M2008HF, M2616, and M2216ACD Meridian Modular Telephones.

The Meridian Modular Telephones are designed to provide cost-effective integrated voice and data communication capability. They interface with the Digital Line Card (DLC). No additional hardware is required at the line circuit to provide data communication. Meridian Modular Telephones are connected to the system through a two-wire loop carrying two independent 64 Kb/s PCM Channels with associated signaling channels. One of the two PCM channels is dedicated to voice while the other is dedicated to data traffic. Line cords and handset cords on all Meridian Modular Telephones are equipped with snap-in TELADAPT connectors for easy and quick connecting procedures.

Three distinct versions of Meridian Modular telephones, distinguished by the first four letters in the upper left-hand corner of the model identification label on the bottom of the telephone, are available. The three versions are the "NTZK" models, the "NT2K" models with date code prior to April 24, 1998, and both the "NT9K" models and the "NT2K" models with date code of April 24, 1998 and later. The two jacks face in the same direction on "NT2K" and "NT9K" telephones, and in opposite directions on "NTZK" telephones. When appropriate, differences between the models are noted in this document.

Software requirements

The option number for the Meridian Modular Telephones is 170. The mnemonic is ARIE. The DSET package (88) and the TSET package (89) are required.

Intelligent Peripheral Equipment requirements

The telephones interface with the DLC. The DLC supports eight Integrated Voice and Data ports; each port supports one data and one voice channel. A voice TN and a data TN are assigned in the software.

General description

This section describes the various features and capabilities of the following Meridian Modular Telephones.

M2006 — A single line telephone with 6 programmable function keys. See [Figure 50 "M2006 modular telephone" \(page 260\)](#).

M2008/M2008HF — A multi-line telephone with 8 programmable function keys. The M2008HF contains an integrated Handsfree unit. See [Figure 51 "M2008/M2008HF modular telephone" \(page 261\)](#).

M2616 — A high performance multi-line telephone with 16 programmable function keys and integrated Handsfree unit. See [Figure 52 "M2616 modular telephone" \(page 262\)](#).

M2216ACD-1 — A multi-line telephone for ACD operations. It has 15 programmable function keys, a special ACD Display Module and two RJ-32 jacks for modular electret headsets. See [Figure 55 "M2216ACD-1 and -2 left side showing headset jacks" \(page 271\)](#).

M2216ACD-2 — A multi-line telephone for ACD operations. It has 15 programmable function keys, and a special ACD Display. It is similar to model 1, but with one PJ-327 jack for a carbon agent headset and one RJ-32 jack for an electret supervisor headset. See [Figure 55 "M2216ACD-1 and -2 left side showing headset jacks" \(page 271\)](#).

Note: If a headset is desired for the M2216ACD sets, the amplified type is strongly recommended.

Figure 50
M2006 modular telephone

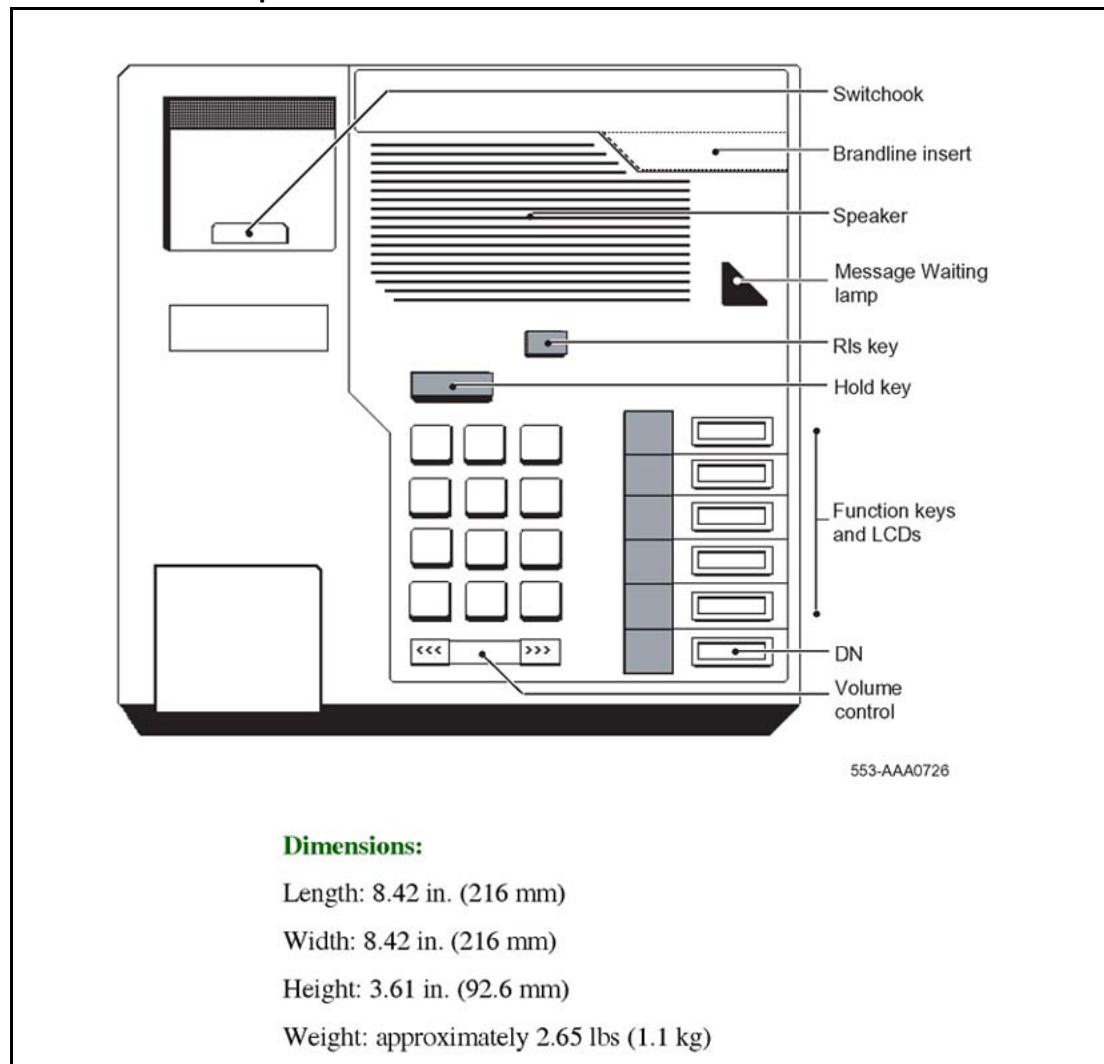

Figure 51
M2008/M2008HF modular telephone

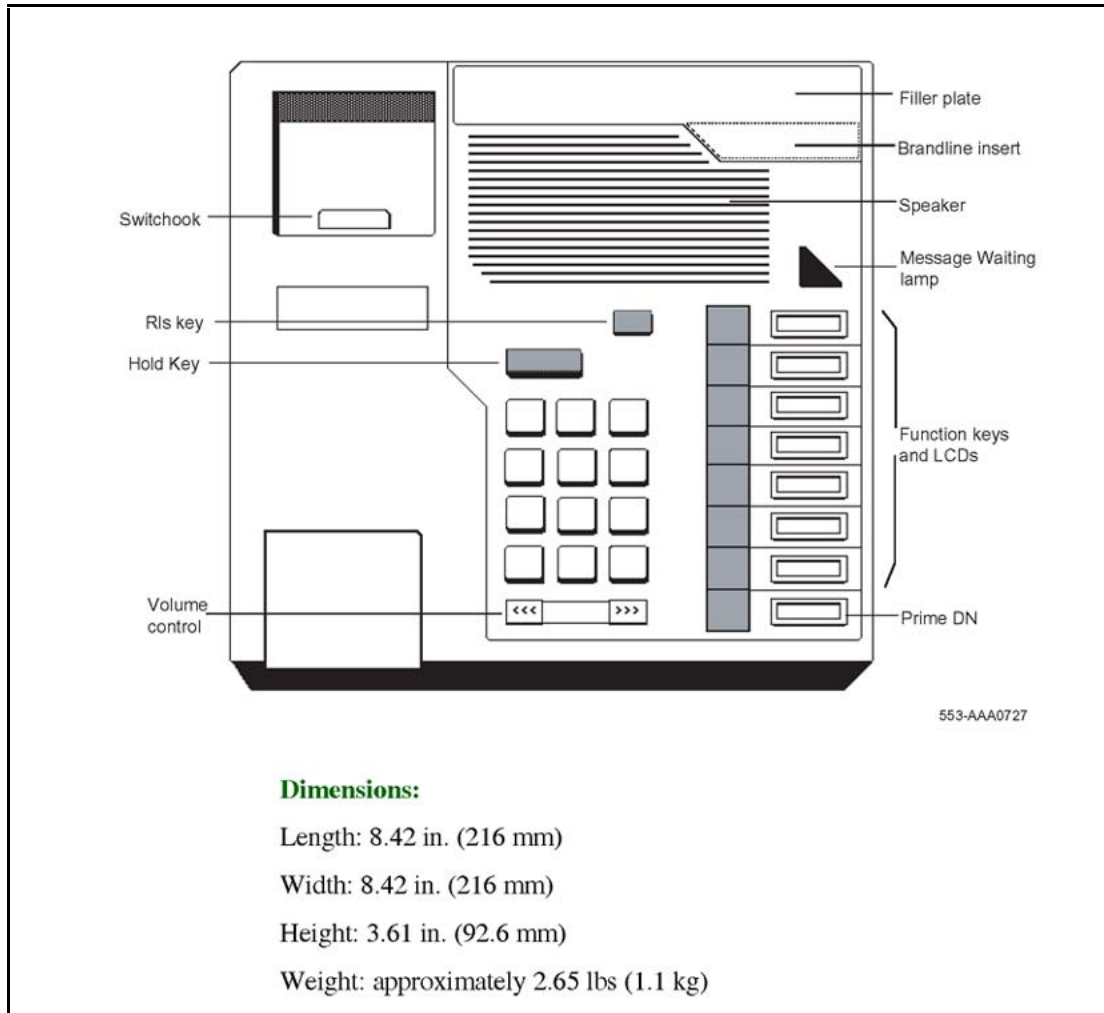

Figure 52
M2616 modular telephone

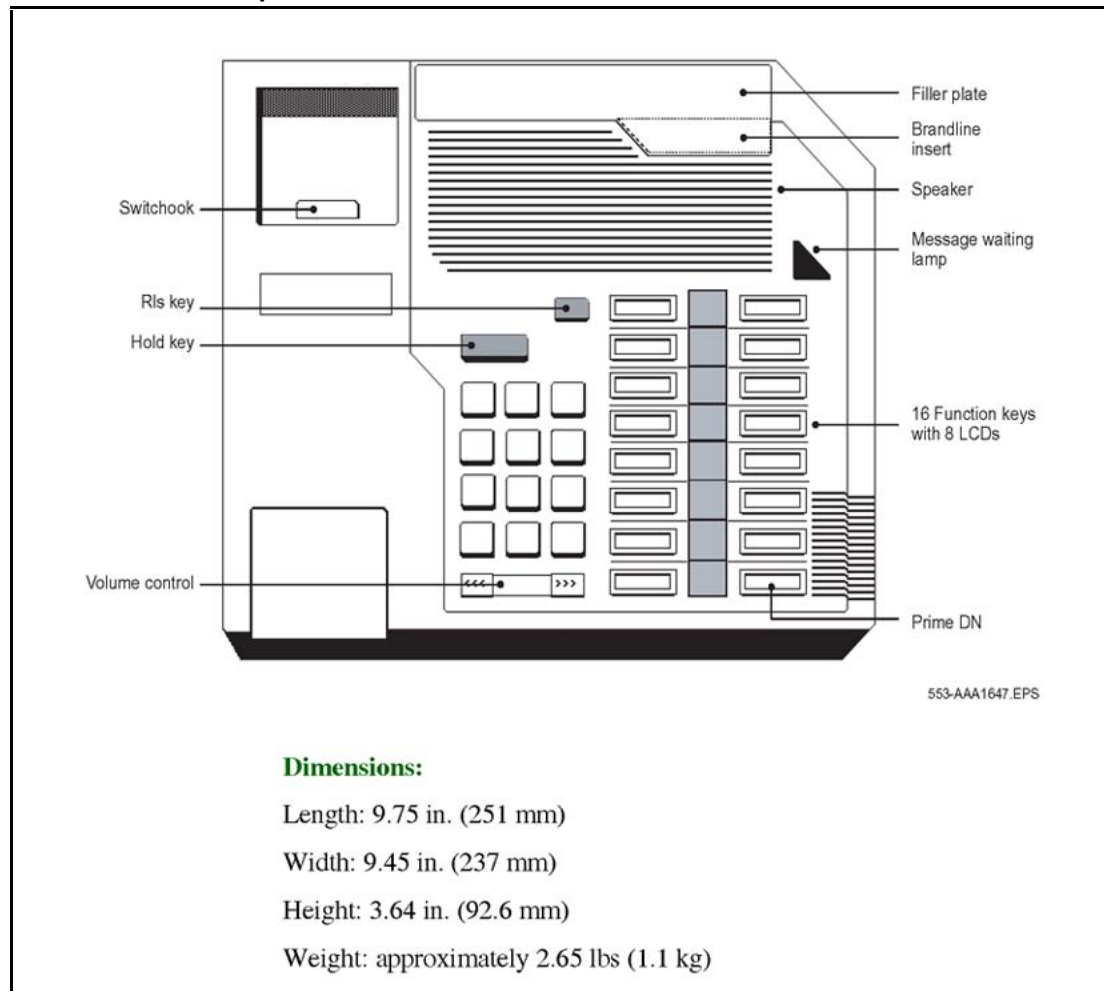
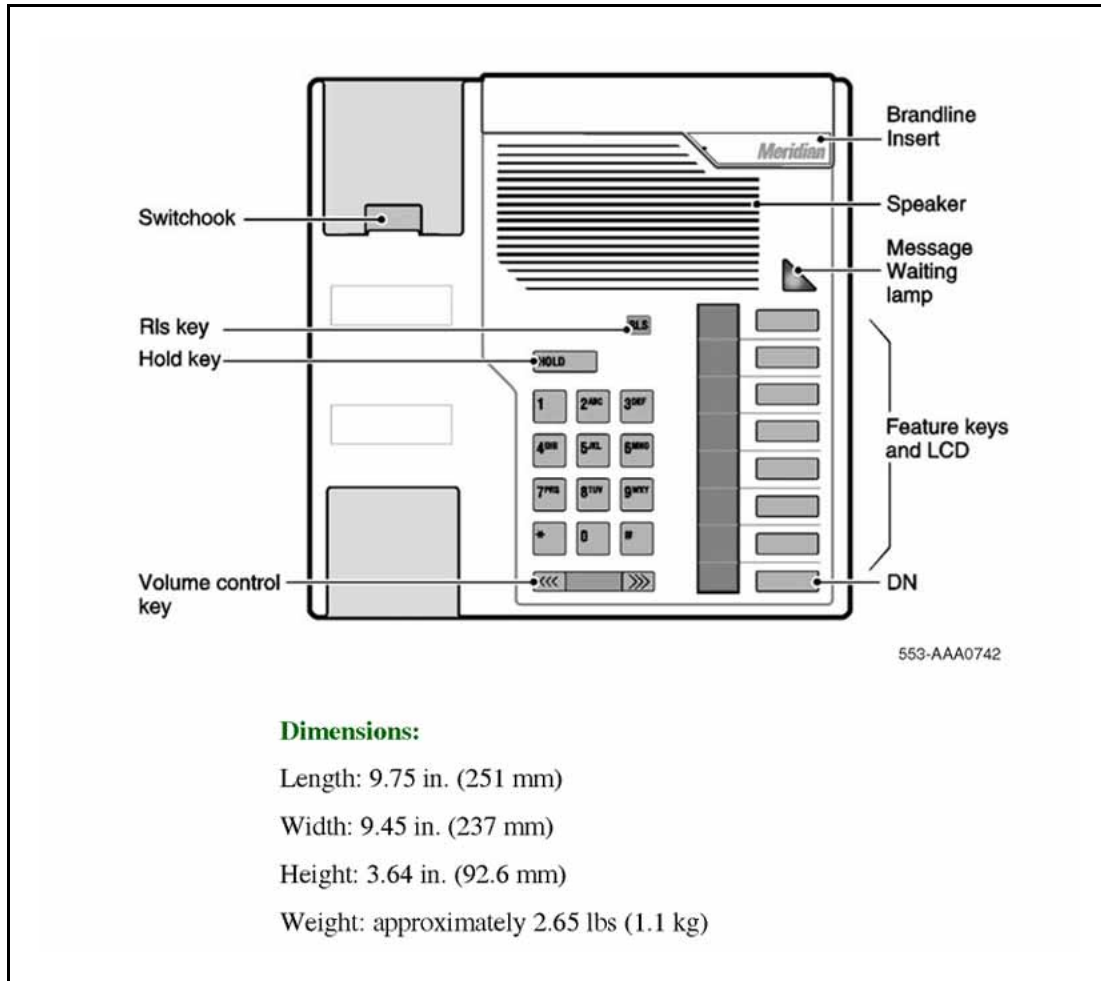

Figure 53
M2216ACD-1 and -2 modular telephones



Physical description

All of the Meridian Modular Telephones are equipped with:

- Hold key
- Release key
- Volume control
- Message Waiting lamp
- Speaker

Each modular telephone also has a number of programmable keys with LCD indicators that can be assigned to any combination of directory numbers and features (only one DN for the M2006). The lower right-hand key (key 0) is reserved for the Primary DN.

When equipped with a Display module or MCA, key 07 is automatically assigned as the Program key and cannot be changed. Key 05 becomes the Program key on the M2006, if equipped with MCA.

The M2006 is a single line telephone and accepts only one DN. The remaining five key/lamp pairs can be assigned any feature that is not considered a DN, such as Transfer, Call Forward, or Conference. Features that cannot be assigned are those that are considered DNs: Voice Call and 2-way Hotline, for example. Attempting to assign more than one DN to the M2006 causes the telephone to disable itself and all LCDs light steadily. It will return to its normal operating state when service change removes all secondary DNs.

LCD indicators support 4 key/LCD states:

Function	LCD state
idle	off
active	on (steady)
ringing	flash (60 Hz)
hold	fast flash (120 Hz)

*** An indicator fast flashes when a feature key is pressed but the procedure necessary to activate the feature has not been completed.**

Volume control

One key with two toggle positions controls volume. Pressing the right "volume up" or left "volume down" side of the key incrementally increases or decreases the volume for the tone or sound which is currently active. The volume settings are retained for subsequent calls until new volume adjustments are made. If the telephone is equipped with a Display Module, volume can be adjusted at any time with the setting displayed on the screen (in Program mode).

Note: All Meridian Modular Telephones manufactured after June 1996 are compliant with the HAC volume-level requirements issued by the FCC for handset volume control for the hearing impaired. The highest volume-level setting provides 13.5 dB over nominal.

Handset volumes can be configured to return to nominal on a per-call basis.

You can adjust the volume of the following tones, while they are audible:

- ringing
- handsfree (M2616)
- handset/headset
- buzz
- on-hook dialing

When the telephone is disconnected, all volume levels will return to default values upon reconnection.

When the telephone is operating on loop power alone, the highest (eighth) step in volume cannot be reached (as seen when using Display in Program mode).

Message Waiting lamp

Each Meridian Modular Telephone has a red triangle in the upper right-hand corner that lights brightly to indicate a message is waiting. This LED is the primary message waiting indicator and lets you know a message is waiting regardless of whether the telephone has a message waiting key/lamp pair. You must have Message Waiting CCOS configured.

If you do assign a message waiting key/lamp pair, there will be two indications of a message waiting:

- the red Message Waiting triangle lights, and
- the LCD associated with the Message Waiting key flashes.

You may assign an Autodial key that dials the message center (or voice mail system) to avoid the double indication, or have no key/lamp pair assigned to the message center.

Handsfree/Mute key (M2008HF and M2616 only)

Handsfree (if software assigned), allows the user to talk to another party without lifting the handset. Activate Handsfree by depressing the Handsfree/Mute key (key 15, top left) or by selecting a DN without lifting the handset. Once Handsfree is activated, it can be deactivated by picking up the handset or by ending the call using the Release (RIs) key. If Handsfree is not software assigned, you can assign any other feature to key 15.

When the Handsfree/Mute key is pressed during a Handsfree call, the microphone is deactivated while the speaker remains active, preventing the other party from overhearing local conversations. The Handsfree

LCD indicator flashes while the microphone is muted. Pressing the Handsfree/mute key again reactivates the microphone and the Handsfree LCD lights steadily.

The Class of Service feature for M2616 Handsfree control enables system administrators to enable/disable the Handsfree option on the M2008HF (Handsfree) telephone through software. M2008HF telephones ship from the factory with a hardware jumper enabled to enable the Handsfree option for existing software releases.

System software overrides the hardware setting and default to Handsfree Denied (HFD.) If the handsfree option is desired, the system administrator simply enables Handsfree through the Class of Service prompt HFA included in LD 11 for the M2008 telephones (consistent with M2616).

Service Change Parameters

Table 75
LD 11, Allow/Deny Handsfree for M2008HF

Prompt	Response	Description
REQ:	NEW CHG	
TYPE:	M2008	M2008 telephone
CLS	(HFD)	Digital Telephone Handsfree Denied
	HFA	Digital Telephone Handsfree Allowed

Handsfree operates as if an off-hook operation had been performed. For example, when the telephone is idle, pressing the Handsfree/Mute key turns on the Handsfree and selects a DN (depending on line selection as assigned through COS), enabling the user to make a call. When a call comes in to an M2008HF/M2616 and the set is ringing, pressing the Handsfree/Mute key turns on the Handsfree and enables the user to answer the incoming call (depending on COS-assigned line selection) without picking up the handset.

Features and options

[Table 76 "Hardware features and options" \(page 267\)](#) lists the distinctive characteristics of each Meridian Modular Telephone and shows the optional hardware you can add to each.

Table 76
Hardware features and options

	M2006	M2008/ 2008HF	M2616	M2216 ACD-1	M2216 ACD-2
Programmable keys	6	8	16	16	16
Handsfree microphone			standard		
Optional hardware:					
Display		x	x	standard	standard
Key Expansion Module			x	x	x
Meridian Communications Adapter (MCA)	x	x	x	x	x
Meridian Programmable Data Adapter (MPDA)	x	x	x	x	x
External alerter interface	x	x	x	x	x
Analog Terminal Adapter (ATA)	x	x	x	x	x
Brandline insert	x	x	x	x	x
<p>Note 1: In this table, x indicates available features for the set type listed along the top row.</p> <p>Note 2: If the set is equipped with a Display, Meridian Programmable Data Adapter, or Meridian Communications Adapter, the number of programmable keys is reduced by one, as key 07 (key 05 on M2006) automatically becomes the Program key.</p>					

The optional hardware for Meridian Modular Telephones is described below.

Display Module

A 2-line by 24-character Display Module provides system prompts, feedback on active features and valuable calling party information. In addition, you can modify various set features such as volume and screen contrast using the Program key (top right function key). You can enable a Call Timer which times calls made or received on the prime DN.

Note: The Display Module is not supported on M2006.

Note: The Display Module requires a Power Supply Board on M2008.

Two types of Display Module are available:

- North American Display — Supports normal business features in two languages, English and Quebec French.
- Special Applications Display — Supports the following features:

- Automatic Call Distribution (ACD)
- Hospitality
- 6 languages (English, Quebec French, Parisian French, German, Spanish, Dutch)

A Special Applications Display Module comes as standard equipment on the M2216ACD telephones. M2008 or M2616 telephones used as ACD telephones require the Special Applications Display.

Note: It is possible to adjust the Display screen contrast so that it is too light or too dark to read. If you cannot read the Display, disconnect and then reconnect the line cord to return to the default settings.

Meridian Programmable Data Adapter

The Meridian Programmable Data Adapter (MPDA) mounts within the telephone (see [Figure 56 "Back of telephone showing Meridian Programmable Data Adapter" \(page 272\)](#)) and allows asynchronous ASCII terminals, personal computers and printers to be connected to the telephone using an RS-232-D (subminiature) interface. The MPDA has multilingual capability.

It requires additional power. ["Power requirements" \(page 276\)](#)

For more information, see ["Meridian Programmable Data Adapter" \(page 281\)](#).

Program key

The Program key is automatically assigned to Meridian Modular Telephones with Display or MPDA added. It allows you to change a variety of display features such as screen format, contrast and language. It also lets you change data parameters such as transmission speed and parity.

The upper right-hand key (key 05 on M2006, key 07 on all others) automatically becomes the Program key when Display, MCA, or MPDA is configured with the telephone. The Program key is local to the set and shows blank when you print key assignments in LD 20.

See ["Meridian Modular Telephones add-on modules installation" \(page 299\)](#) for descriptions of MCA, MPDA, and ATA and their requirements.

External Alerter Interface

The External Alerter Board provides an interface to standard remote ringing devices, such as a ringing unit installed in a location separate from the telephone. The Meridian External Alerter and Recording Interface (MEARI) is not the remote ringer itself, but provides access to standard, off-the-shelf remote ringing devices. The Alerter Board requires additional power (see ["Power requirements" \(page 276\)](#)).

You can program the MEARI to activate a ringer (or light) when the telephone rings or when the telephone is in use (off-hook). A call to any DN configured on the telephone triggers the alerter. The MEARI alerts to one active call at a time; if the telephone is already active on a call, a second call will not activate MEARI.

For more information on installing and setting up MEARI, see [“External Alerter Board” \(page 337\)](#).

Key Expansion Module

A modular 22-key unit can be attached to any 16-key Meridian Modular Telephone except 2016S. See [Figure 54 “M2616 with Display Module and Key Expansion Module” \(page 270\)](#). The extra keys can be assigned to any combination of lines and features. You can add up to two expansion modules to a single telephone, providing a total of 60 line/feature keys. You will need a separate footstand for the module(s), one for a single module, one for a double. The expansion module requires additional power. See [“Power requirements” \(page 276\)](#).

The Key Expansion Module connects to the telephone through a ribbon cable running from the base of the telephone. It is physically connected to the telephone by the footstand. NT2K22VH or later vintage key lamp modules are required for CISPR22, Class B compliance.

Figure 54
M2616 with Display Module and Key Expansion Module

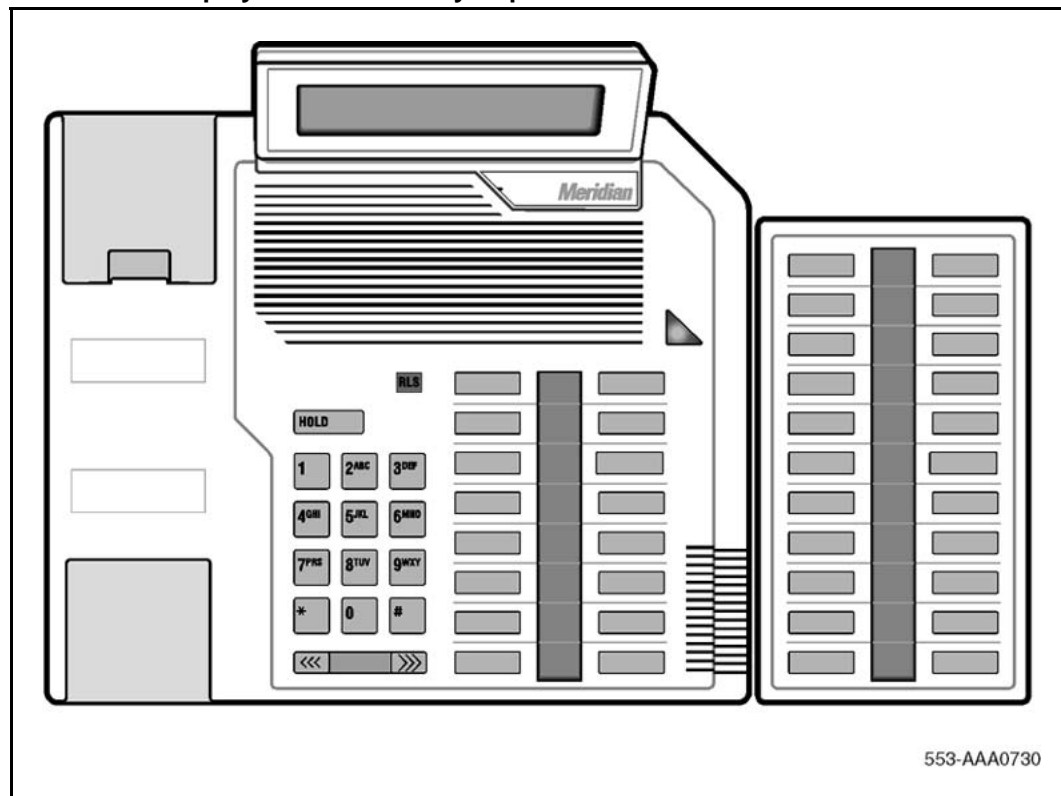

Brandline Insert

The filler plate on the telephone or Display Module contains a removable insert designed to accommodate custom labeling. You can order blank Brandline Inserts and have a printer silk screen your company logo on them. Brandline Inserts snap easily into and out of the filler plate.

Headset

The M2216ACD-1 is compatible with most headsets. Amplified headsets are strongly recommended. The headset/handset interface of the M2216ACD-1 can be adjusted for optimum performance using the Program key. Three settings are available:

- Plantronics Polaris
- GN Netcom Profile
- NT Liberation

Try using the headset with each of the three settings to determine which works best. Trial with both internal and external calls is also recommended to determine optimum performance.

When the amplified headset is used, two choices for volume control are available :

- the rocker control on the telephone
- the switch on the headset

The settings which provide the clearest communication with the least amount of distortion are the amplifier setting higher than the telephone volume control.

The supervisor and agent jacks are not interchangeable. A headset must be plugged into the agent jack if the telephone is to receive ACD calls.

The M2216ACD-2 agent jack is compatible with any standard carbon headset. The headset interface of the M2216ACD-2 is not adjustable.

Any recording device connected to the receive path of a Meridian Modular Telephone must meet these requirements:

- load impedance at least 8K ohms across the audio band
- connect in parallel across pins 3 and 4 of the handset/headset jack
- isolate power source from the headset/handset jack

Figure 55
M2216ACD-1 and -2 left side showing headset jacks

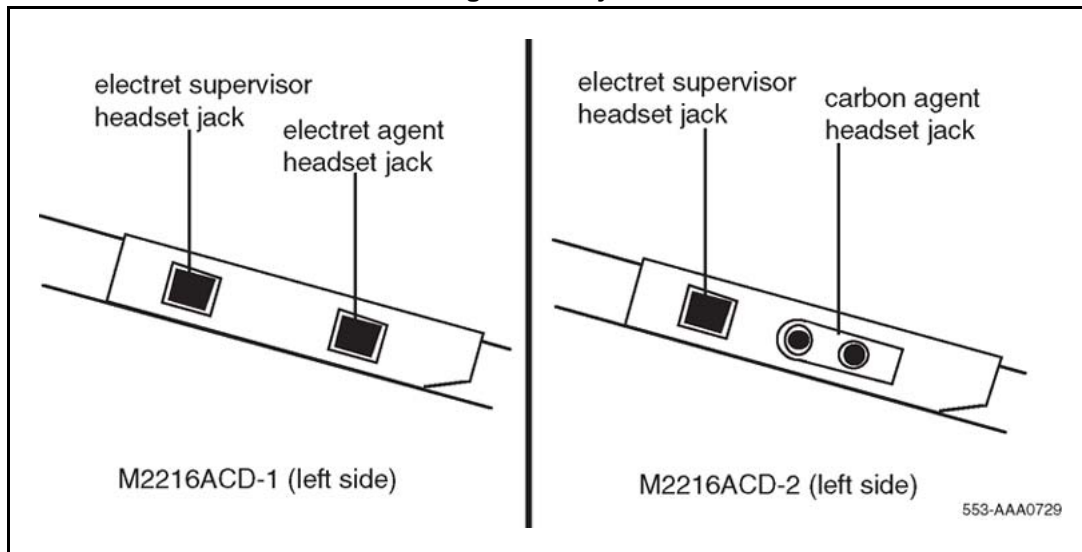

M2006/M2008/M2008HF/M2616/M2216ACD telephones

You can use an electret headset in the handset port of the M2006, M2008, M2008HF, M2616, and M2216ACD telephones. Choose an amplified headset that draws power from a battery or AC transformer (power is not provided by the telephone). The amplifier must draw less than 400 micro amps from the telephone jack.

The headset should be designed to work with a telephone jack with these characteristics:

- Transmit interface: +5 V through 10K DC bias resistance with maximum current of 500 micro amps. The differential input impedance is 10K ohms. Connects to pins 2 and 5 of the handset jack.
- Receive interface: single ended output with output impedance of 180 ohms. Connects to pins 3 and 4 of the handset jack.

Figure 56
Back of telephone showing Meridian Programmable Data Adapter

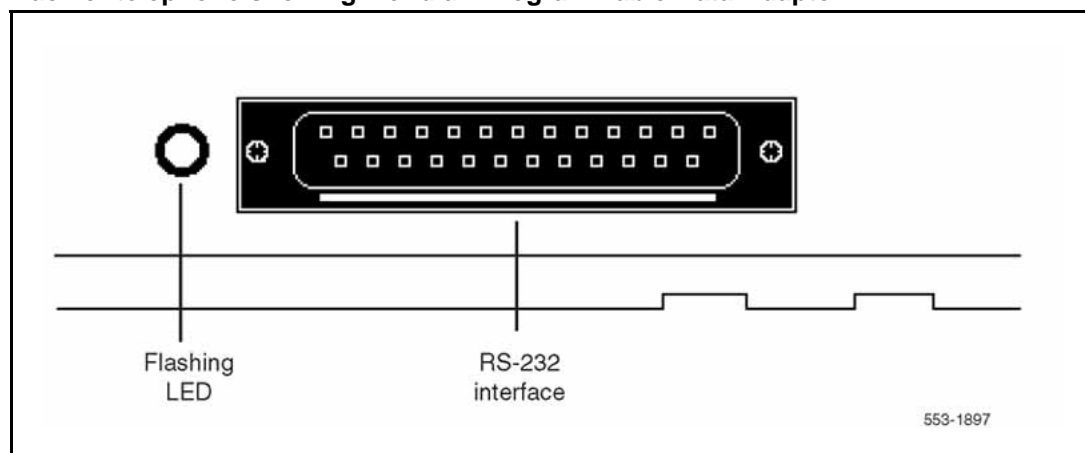
**Relocation**

This section describes how to relocate a Meridian Modular Telephone and its associated dataport Terminal Number (TN) without the intervention of a technician.

Modular Telephone Relocation is designed specifically for the Meridian Modular Telephones and is an enhancement to Automatic Set Relocation. If dataport TN information exists for the terminal, it is automatically relocated when the telephone is relocated.

When a telephone is relocated-out, a relocation block is built to store the relocation information in the protected data area. The relocation block includes the old TN, the terminal ID information, the serial number of the telephone, and other information.

This feature uses the unique serial number and terminal ID of the Meridian Modular Telephone to identify the terminal being relocated and to reduce the number of manual steps needed for relocation.

See Automatic Set Relocation in *Features and Services Fundamentals-Six Books (NN43001-106_B1-B6)* () for complete details.

How to relocate a Meridian Modular Telephone

Step	Action
1	Go off-hook, receive dial tone, and enter Relocation Code (either SPRE +81 or Flexible Feature Code).
2	Enter optional security code as defined in LD 15 (a burst of tone confirms that the telephone is relocated-out).
3	Take the telephone to the new location and plug it in (a confirmation buzz from the speaker indicates the telephone is in service).

--End--

Specifications

The following specifications govern the performance of the Meridian Modular Telephones under the environmental conditions described.

Environmental and safety considerations

All digital telephones and their associated options meet the requirements of Electronic Industries Association (EIA) specification PN-1361.

Temperature and humidity

Temperature range	0° to 50° C (32° to 104° F)
Relative humidity	5% to 95% (non-condensing). At temperatures above 34°C (93°F) relative humidity is limited to 53 mbar of water vapor pressure.

Temperature range	-50° to 70° C (-58° to 158° F)
Relative humidity	5% to 95% (non-condensing). At temperatures above 34°C (93°F) relative humidity is limited to 53 mbar of water vapor pressure.

Electromagnetic interference

The radiated and conducted electromagnetic interference meets the requirements of Subpart J of Part 15 of the FCC rules for class A computing devices.

NT2K model sets with all options meet CISPR22, Class B requirements.

Line engineering

Meridian Modular Telephones use twisted-pair wiring on transmission lines selected by the rules given in ["Digital telephones line engineering" \(page 223\)](#) &c. The maximum permissible loop length is 3500 ft. (915 m), assuming 24 AWG (0.5 mm) standard twisted wire with no bridge taps. A 15.5 dB loss at 256 KHz defines the loop length limit (longer lengths are possible, depending on the wire's gauge and insulation). The Meridian Modular Telephones use a 6-conductor line cord (A0346862).

[Table 77 "Loop lengths for digital telephones" \(page 274\)](#) gives detailed information on loop lengths.

Table 77
Loop lengths for digital telephones

	NT8D02
PVC insulated cable (polyvinyl chloride)	
22 or 24 AWG	0–3500 ft. (0–1067 m)
26 AWG	0–2600 ft. (0–793 m)
Note 1: No bridge taps or loading coils are allowed.	
Note 2: Effect of line protector at MDF reduces loop length by 500 ft.	



CAUTION

Damage to EquipmentService Interruption

Use only the line cord provided with Meridian Modular Telephones. Using a cord designed for other digital telephones could result in damage to the cord or a loss of set functionality.

[Figure 57 "Block diagram of MPDA and Meridian Modular Telephone" \(page 275\)](#) shows a simplified block diagram of the Meridian Modular Telephone, MPDA and DLC.

Figure 57
Block diagram of MPDA and Meridian Modular Telephone

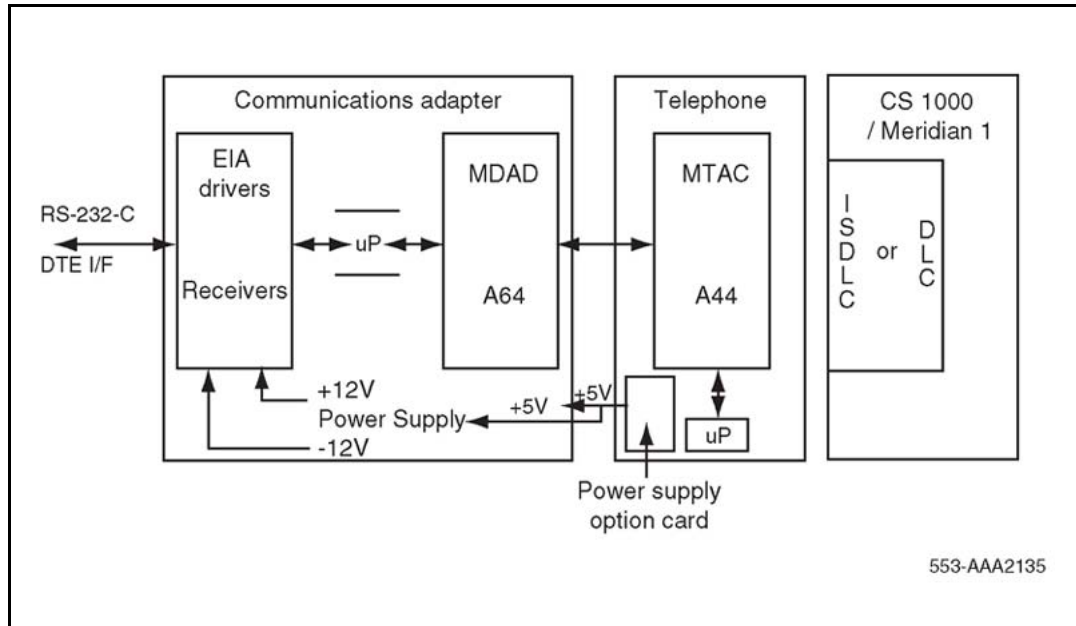

Local alerting tones

Each telephone provides four alerting tones and a buzz sound. The system controls the ringing cadence by sending tone-ON and tone-OFF messages to the telephone. The alerting tone cadences cannot be changed from the telephone, but can be altered for individual Meridian Modular Telephones by software controlled adjustments in the system. See *Software Input Output Administration (NN43001-611)* ().

All other telephony tones, such as dial tone or overflow, are provided by the system from a Tone and Digit Switch.

Alerting tone characteristics

The tone frequency combinations are as follows:

Tone	Frequencies	Warble Rate (Hz)
1	667 Hz, 500 Hz	10.4
2	667 Hz, 500 Hz	2.6

M2006/M2008/M2008HF:

3	1600 Hz, 2000 Hz	10.4
4	1600 Hz, 2000 Hz	2.6

M2616/M2216ACD:

3	333 Hz, 250 Hz	10.4
4	333 Hz, 250 Hz	2.6

A 500 Hz buzz signal is provided for incoming call notification while the receiver is off-hook.

Power requirements

The M2006, M2008, M2616 (basic configuration and with Display Module) and M2216ACD-1 are loop powered. Loop power consists of a -30 V AC power source and assumes a 3500 ft. (915 m) maximum loop length of 24 AWG wire and a minimum 15.5 V AC at the telephone terminals.

Note: The loop length limit is defined by a 15.5 dB loss at 256 KHz. Longer lengths can be determined using the wire's gauge and insulation.

The Handsfree feature, which is integrated into the M2616, requires no additional power.

Some configurations of telephones and options need more than basic loop power to operate. [Table 78 "Power requirements" \(page 277\)](#) lists the Meridian Modular Telephones and shows when additional power is needed to operate the telephone or its optional hardware. Power Supply Boards come installed in factory-assembled configurations which require additional power.

Note 1: If a power failure occurs, configurations that require loop power will only continue to work if the system has battery backup. Only those options which require additional power will cease to function.

Note 2: During a power failure, the carbon agent headset on the M2216ACD-2 will fail and the electret supervisor's jack can be used as an agent jack. If no headset was plugged in to the electret jack at this time, the call is dropped, the agent logged off and must log in again once the electret headset is plugged in. When power is restored, the carbon jack returns automatically.

Table 78
Power requirements

Telephone type	Loop power	Additional power (Power Supply Board)
M2006	Basic configuration	Any option(s)*
M2008/2008HF	Basic configuration	Any option(s)
M2616	Basic configuration (with Handsfree) and Display	Programmable Data Adapter Key Expansion Module External alerter interface
M2216ACD-1	Basic configuration (with Display)	Any option(s)
M2216ACD-2	No	All configurations
*No display can be added to the M2006 set.		

Power Supply Board

The power supply option consists of a Power Supply Board which mounts inside the telephone, coupled with an external wall-mount transformer or closet power supply which provides power to the Power Supply Board. The Power Supply Board receives its power through pins 1 and 6 of the line cord.

When installing an MCA or MPDA to NTZK or NT2K phone sets with a date code prior to January 1998, a Power Option board is required, along with an additional power source. When installing an MCA in an NT9K phone set or an NT2K with date code of January 1998, install only the MCA (an additional Power Option board and Jumper board are not required).

The Power Supply Board connects to the telephone through a 14 pin bottom entry connector.

The Power Supply Board comes factory installed with any configuration of the M2216ACD-2. The M2006 and M2008 require the Power Supply Board with the addition of any option. The M2616 requires the Power Supply Board with any option except the Display Module.

Refer to [Table 79 "NT2K model Power requirements, Meridian Modular Telephone sets"](#) (page 278) and [Table 80 "NTZK model Power requirements, Meridian Modular Telephone sets"](#) (page 278) for power supply board requirements.

Table 79
NT2K model Power requirements, Meridian Modular Telephone sets

Telephone type	Loop power	Additional power (Power Supply Board and Transformer)
M2006	Basic configuration	Any option(s)* (MPDA, External Alerter Interface, MCA)
M2008/M2008HF	Basic and Display configurations	MPDA, External Alerter Interface
M2616	Basic, Display, and Handsfree configurations and Key Expansion Module(s)	MCA, MPDA, External Alerter Interface, MCA
M2216ACD	Basic configurations (with Display) Key Expansion Module(s).	MPDA, Key Expansion Module, External Alerter Interface, MCA
*No display can be added to the M2006 set.		

Table 80
NTZK model Power requirements, Meridian Modular Telephone sets

Telephone type	Loop power	Additional power (Power Supply Board)
M2006	Basic configuration	MPDA, External Alerter Interface, MCA (optional),
M2008	Basic configuration	Any option(s)
M2616	Basic configuration (with Handsfree) and Display.	MPDA, Key Expansion Module, External Alerter Interface, MCA (optional)
M2216ACD-1	Basic configuration (with Display)	MPDA, Key Expansion Module, External Alerter Interface, MCA (optional)
M2216ACD-2	N/A	Any configuration

Local plug-in transformer

A single winding transformer equipped with a 10 ft. (3 m) cord of 22 AWG two-conductor stranded and twisted wire with a modular RJ-11 duplex adapter (refer to [Figure 58 "Configuration of local plug-in transformer" \(page 279\)](#)) can provide the additional power needed to operate the telephone and its options.



CAUTION

Do not plug any equipment (computer, modem, LAN card) other than the Meridian Modular Telephone into the RJ-11 transformer adapter, as damage to equipment may result.

Figure 58
Configuration of local plug-in transformer

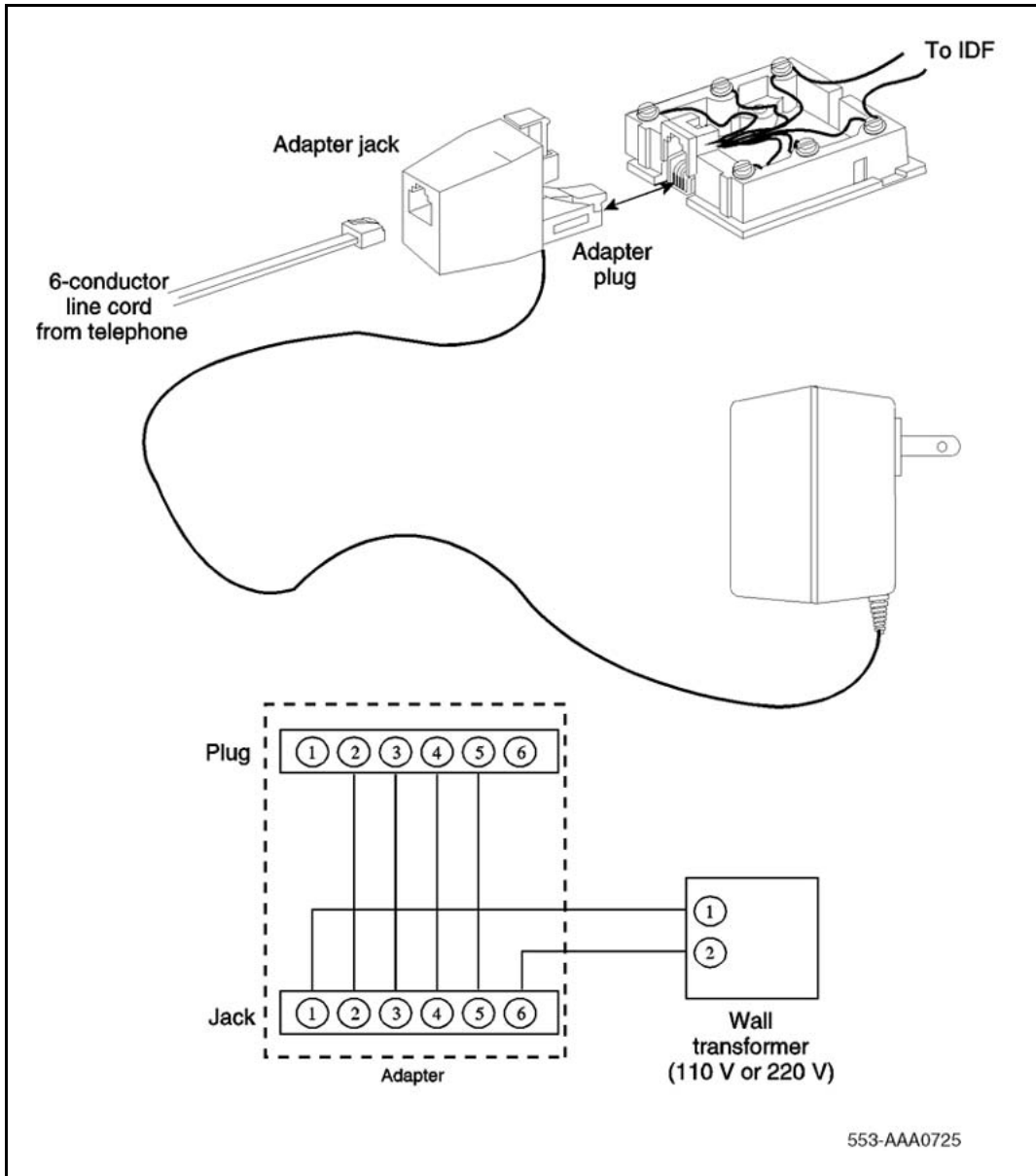

120 V transformer (AO367335 or equivalent)

The following minimum specifications must be met by this transformer:

Input voltage	120 V AC/60 Hz
No load output voltage	29 V AC maximum
Voltage at rated current	26.7 V AC minimum
Rated load current	700 mA

240 V transformer (AO367914 or equivalent)

The following minimum specifications must be met by this transformer:

Input voltage	240 V AC/50 Hz
No load output voltage	29 V AC maximum
Voltage at rated current	26.7 V AC minimum
Rated load current	700 mA

Note 1: The telephone cannot be wall-mounted over the wall jack when using a transformer, because of the size of the RJ-11 adapter. Hang the telephone above or to the side of the jack and run the line and power cords to it.

Note 2: The above-mentioned transformers can also be used with outlets identified as 110V or 220V.

Closet power supply

Closet power can be obtained from an AC transformer for loops of 100 ft. (30 m) or less, or a DC transformer for loop lengths of 650 ft. (197 m) or less. An equivalent power source can be used but must maintain isolation of outputs to the terminal. Refer to [Figure 59 "Closet power supply configuration"](#) (page 281).



CAUTION

When using closet power, do not plug the TELADAPT connector into any equipment (computer, modem, LAN card) other than the Meridian Modular Telephone, as damage to equipment may result.

Note 1: All terminals must be isolated from the input winding and each terminal must be isolated from all other terminal windings. A separate winding is required for each terminal, and grounds should not be connected.

Note 2: The QUT1 closet power supply source is not compatible with Meridian Modular Telephones.

The AC source should be rated at 29 V AC, 700 mA isolated. The DC source should be rated at 42 V DC, 300 mA isolated, with current limiting output of 1 amp.

Figure 59
Closet power supply configuration

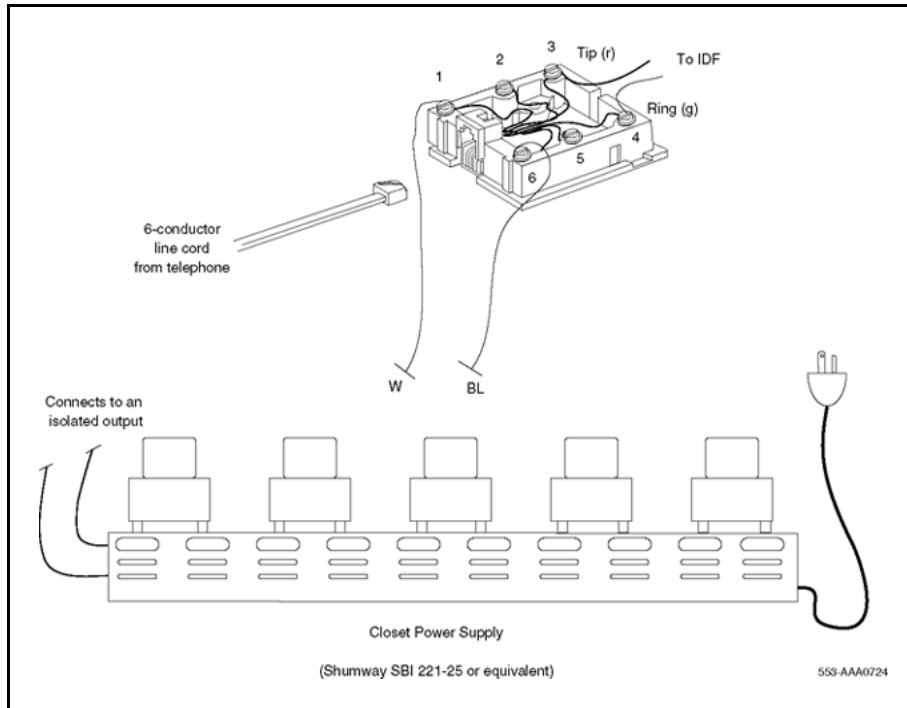

Meridian Programmable Data Adapter

When a Meridian Modular Telephone is equipped with the Meridian Programmable Data Adapter (MPDA), you can make a data call using keyboard dialing from your attached terminal. You can carry on voice and data communication simultaneously without causing any mutual interference.

The MPDA communicates with Data Terminal Equipment (DTE) having characteristics as shown in [Table 81 "MPDA data characteristics" \(page 281\)](#):

Table 81
MPDA data characteristics

Data type	ASCII
Synchronization	Asynchronous, Start-Stop
Number of Bits	8 bits
Parity	none (unchecked)
Data rate	110, 150, 300, 1200, 2400, 4800, 9600, 19200 bits per second (autobaud)

Table 81
MPDA data characteristics (cont'd.)

Stop bits	2 bits for 110 bits per second; 1 bit for all other speeds
Transmission	Full duplex

Note: The MPDA configuration of data parameters is stored locally (although you can set the configuration in the Cabinet systemsystem). You cannot set the data parameters in the system before installing the MPDA in the telephone (the configuration information will be lost).

The keyboard dialing routine may vary with the data equipment being used and reference to the user's data terminal manual may be necessary. For more detailed information, see *Meridian Communications Unit User Guide and Meridian Communications Adapter Reference Guide* () .

The MPDA can establish either data calls or voice calls. You can make data calls using keyboard dialing, keypad dialing or the AT command dialing feature. The AT dialing features lets you originate data calls to local and remote Data Terminal Equipment (DTE) directly from a data terminal keyboard or personal computer. You can make voice calls using AT dialing from your terminal.

Users of personal computers already equipped with a Hayes Smartmodem or users who have a stand-alone Hayes Smartmodem can substitute the MPDA for data integration. The Hayes dialing feature, when used with third party communication software and the digital telephone, will support most of the Hayes Smartmodem features. Third party terminal emulation packages can also be used with Hayes dialing.

Features supported by the MPDA include:

- enhanced Hayes commands, including upper- and lower case dialing, voice call origination through AT dialing, hang up data call, and on-line disconnect of voice call
- script file capabilities allow you to program multiple data resources for automatic resource access
- Voice Call Origination (VCO)

Handsets

This section provides information on Meridian Modular Telephone handsets.

Table 82
Codes for handsets for Meridian Modular Telephone sets, model NTZK

Description	Order Code
Legacy handset, Black	NT0C09EA03
Legacy handset, Ash	NT0C09EA35
Legacy handset, Gray	NT0C09EA93
Note: Handsets designed for NT2K sets (Global handset) do not meet product transmission/reception specifications if used with NTZK sets.	

Table 83
Codes for handsets for Meridian Modular Telephone sets, model NT2K

Description	Order Code
Global handset, Black	NT0C09EK03 / A0400786
Global handset, Ash	NT0C09EK35 / A0400787
Global handset, Gray	NT0C09EK93 / A0400790
Note 1: Handsets designed for NTZK sets (Legacy handset) do not meet product transmission/reception specifications if used with NT2K sets.	
Note 2: Noisy Location, Push-to-Talk, Push-to-Mute, and Mercury Switch handsets do not meet product transmission/reception specifications if used with NT2K sets.	
Note 3: Global handsets are not compatible with M2250 (AE or current AF versions) telephones.	

Appendix

Meridian Modular Telephones installation

Contents

This section contains information on the following topics:

- “Packing and unpacking” (page 285)
- “Installation and removal” (page 285)
 - “Install the Meridian Modular Telephones” (page 285)
 - “Meridian Modular Telephones self-test” (page 288)
 - “Install an M2317 telephone” (page 290)
 - “M2317 telephone self-test” (page 292)
- “Designate telephones” (page 295)
- “Cross-connect the telephones” (page 296)

Note: This section is for reference only. The Meridian Modular Telephones are manufacture discontinued and no longer available.

Packing and unpacking

Use proper care when unpacking any digital telephone. Check for damaged containers so that appropriate claims can be made to the transport company for items damaged in transit.

If a telephone must be returned to the factory, pack it in the appropriate container to avoid damage during transit. Remember to include all loose parts (cords, handset, power unit, labels, and lenses) in the shipment.

Installation and removal

Install the Meridian Modular Telephones

Follow the steps in [Procedure 61 “Installing Meridian Modular Telephones \(M2006/M2008/M2008HF/M2616/M2216ACD\)”](#) (page 286) to install the Meridian Modular Telephones (M2006/2008/2008HF/2616/2216ACD).

Procedure 61
Installing Meridian Modular Telephones
(M2006/M2008/M2008HF/M2616/M2216ACD)

Step	Action
1	Complete the wiring and cross-connections (loop power) before connecting the telephone to the TELADAPT connector. See Figure 60 "Meridian Modular Telephone connections" (page 287) and Figure 61 "Meridian Modular Telephone cross-connections." (page 288) .
2	Place the telephone upside down on a number of sheets of soft, clean paper on a solid, level work surface to prevent damage to movable keys and the telephone's face.
3	Connect the handset cord (5-conductor TELADAPT connectors) to the handset and snap it into place (not applicable to M2216ACD).
4	Connect the other end of the handset cord to the connector in the bottom cover of the telephone. Turn the smooth side of the handset cord up (away from the telephone bottom cover) before tucking it under the restraining tab to ensure that the telephone will sit level on the desk after installation is complete (not applicable to M2216ACD).
5	Connect the line cord to the telephone bottom cover. Route the cord through the channels.
6	Turn the telephone right side up and place it in the normal operating position.
7	Print the directory number on the designation card. Using a paper clip, remove the number lens from the telephone. Insert the designation card and snap the lens back into place.
8	Designate the feature keys.
9	Insert the line cord TELADAPT connector into the connecting block (jack) and snap it into place.
10	Perform the self-test (see Procedure 62 "Meridian Modular Telephones self-test" (page 288)) and acceptance test procedures. See LD 31 in the <i>Software Input Output Administration (NN43001-611)</i> ().
11	Supply the user with a Quick Reference Card and all user documentation. Make sure the SPRE number is printed on the Quick Reference Card.

--End--

Figure 60
Meridian Modular Telephone connections

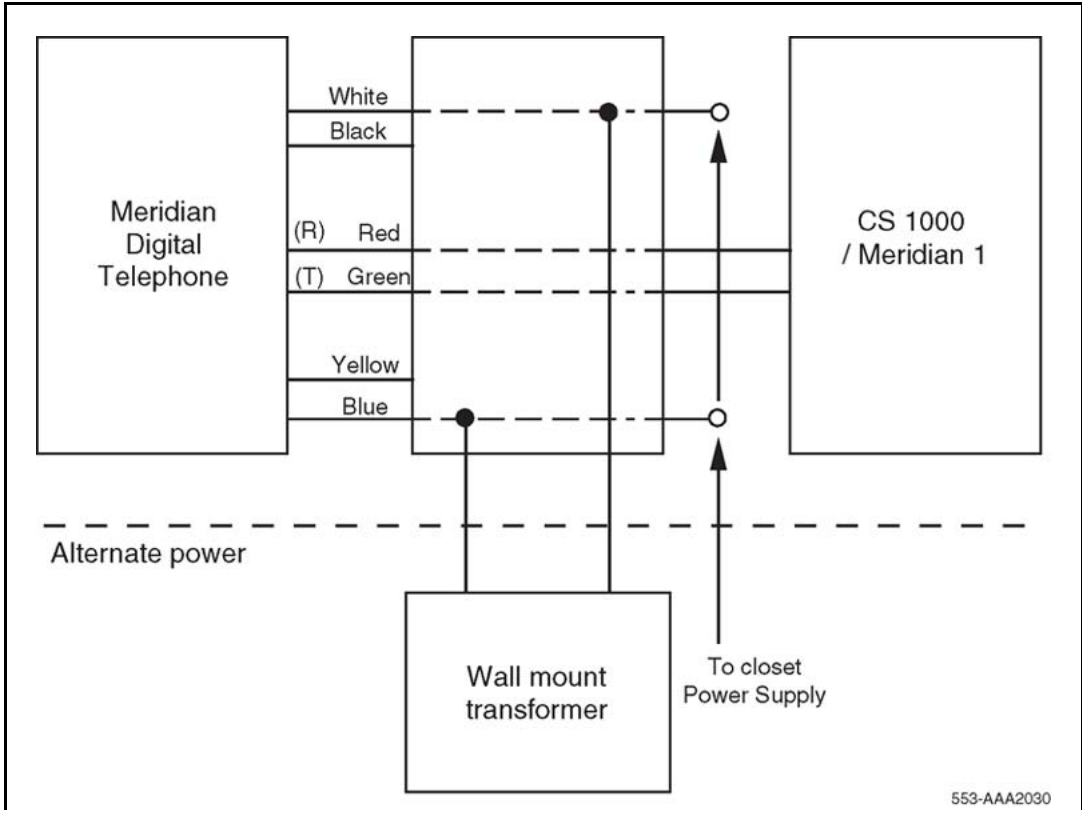
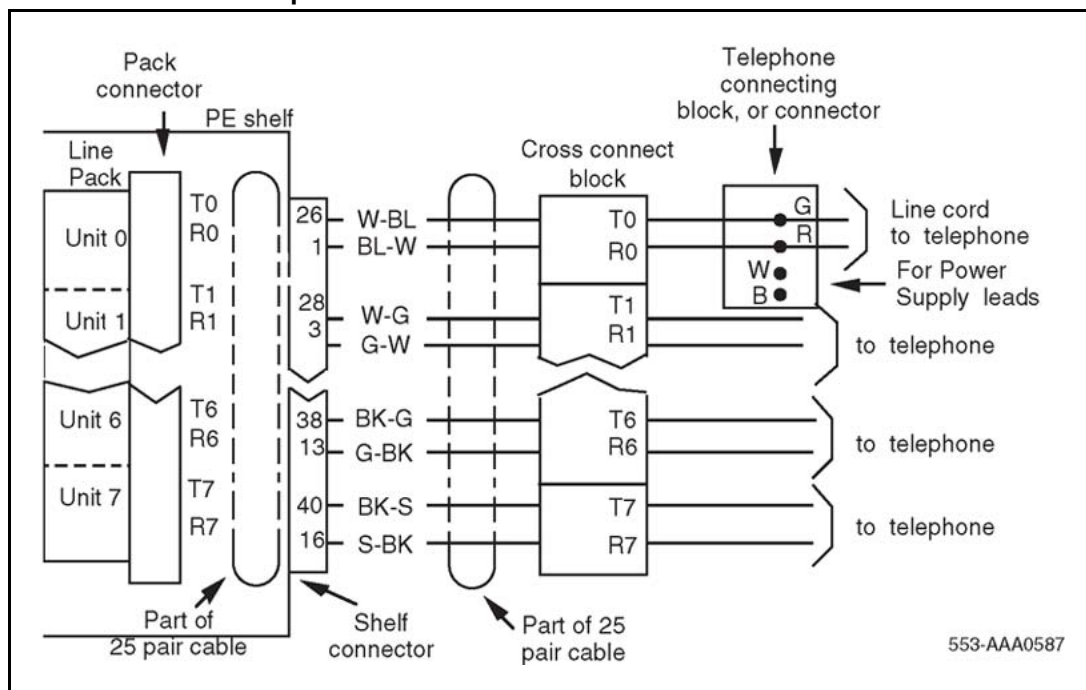

Figure 61
Meridian Modular Telephone cross-connections.



Meridian Modular Telephones self-test

Meridian Modular Telephones have a self-testing capability. Follow the steps in [Procedure 62 "Meridian Modular Telephones self-test"](#) (page 288) to perform the self-test after installing a Meridian Modular Telephone or any of the hardware options to ensure proper operation.

Procedure 62
Meridian Modular Telephones self-test

Step	Action
1	Unplug the line cord from the telephone.
2	While holding down the RLS key, plug in the line cord to the telephone. Let go of the RLS key.
3	Follow the steps in Table 84 "Meridian Modular Telephones self-test steps and results" (page 289) to perform the necessary steps and check results.

--End--

Table 84
Meridian Modular Telephones self-test steps and results

Step	Action	Result
1	Begin test (plug in line cord while holding down the RLS key). The handset is on hook.	Speaker beeps once, all LCDs flash. Message Waiting lamps light steadily. Display reads:LOCAL DIAGNOSTIC MODE PRESS RLS KEY TO EXIT
2	Press each Function key, from zero to fifteen (if there are Key Expansion Modules, continue pressing the Function keys, in any order).	Adjacent LCD goes off when a key is pressed.
3	Press the Hold key.	Speaker beeps.
4	Press each dial pad key.	Speaker beeps each time a key is pressed.
5a	Lift the handset (if applicable). Press the dial pad keys. Replace the handset.	Speaker beeps. Handset beeps.
5b	Plug in the headset (if applicable). Press the dial pad keys. Unplug the headset.	Speaker beeps. Headset beeps.
6	Press the right side of the volume control key. Press the right side of the volume control key. Press the right side of volume control key. Press the right side of the volume control key. Press the right side of the volume control key.	Speaker beeps. Display is filled with dark squares. Speaker beeps. Display is blank. Speaker beeps. Display shows symbols including digits 0–9 and uppercase alphabet Speaker beeps. Display shows symbols including upper- and lowercase alphabet. Speaker beeps. Display shows various symbols.

Table 84
Meridian Modular Telephones self-test steps and results (cont'd.)

Step	Action	Result
	Press the right side of the volume control key.	Speaker beeps. Display shows symbols.
	Press the right side of the volume control key.	Speaker beeps. Display is filled with dark squares.
7	Press the RLS key (end of test).	Message Waiting lamp goes off. Display shows idle screen within 10 seconds.

Install an M2317 telephone

Follow the steps in [Procedure 63 "Installing the M2317 telephone"](#) (page 290) to install an M2317 telephone.

Procedure 63 Installing the M2317 telephone

Step	Action
1	Complete the wiring and cross-connection as shown in Figure 62 "M2317 digital telephone cross-connections" (page 292) before connecting the telephone to the TELADAPT connector block.
2	Place the telephone upside down on a number of sheets of soft, clean paper and on a solid, level work surface to prevent damage to movable keys and the telephone's face.
3	Connect the handset cord 4-conductor TELADAPT connectors to the handset and to the telephone and snap into place.
4	Turn the smooth side of the cord away from the telephone base and secure it under the restraining tab. This ensures that the telephone sits level after the installation is complete.
5	Connect the 6-conductor line cord to the telephone base, and place it under the restraining tabs.
6	Turn the telephone face up, and place it in the normal operating position.
7	Print the Directory Number (DN) on the designation card and place it in the designation card holder.
8	Designate button labels for programmable keys, and place them under the button cover.
9	Insert the line cord TELADAPT connector block and snap it into place. Place the line cord under the restraining tabs.

- 10 Plug the 5 V power supply connector into the back of the telephone.
- 11 Plug the power supply into an AC utility outlet.
- 12 After the M2317 digital telephone is connected to a line that is both enabled and designated as an M2317 digital line, the startup screen displays INITIALIZATION V6.4. Within 5 seconds, the Idle state screen is displayed, and the M2317 is operational. The term V6.4 represents the firmware issue number, and can differ with some installations.
- 13 If the M2317 has been connected to a line that is designated as a digital line, but is not enabled, the display prompts CONTACT SYSTEM ADMINISTRATOR. The line must be enabled using LD 32 from the maintenance terminal, and by enabling the features outlined in the work order. Refer to *Software Input Output Administration (NN43001-611) ()* for the required routines, prompts, and responses.

If the M2317 has been connected to a line that is neither defined as a digital line nor enabled, refer to *Software Input Output Administration (NN43001-611) ()* for required routines, prompts, and responses.
- 14 Verify that all the requested features are enabled by accessing them with the soft keys, or programmable keys, from the M2317 telephone and observing the display screen.
- 15 Perform the self-test (see [Procedure 64 “Performing the M2317 telephone self-test” \(page 292\)](#)) and acceptance test procedures. See LD 31 in the *Software Input Output Administration (NN43001-611) ()*.

--End--

Figure 62
M2317 digital telephone cross-connections

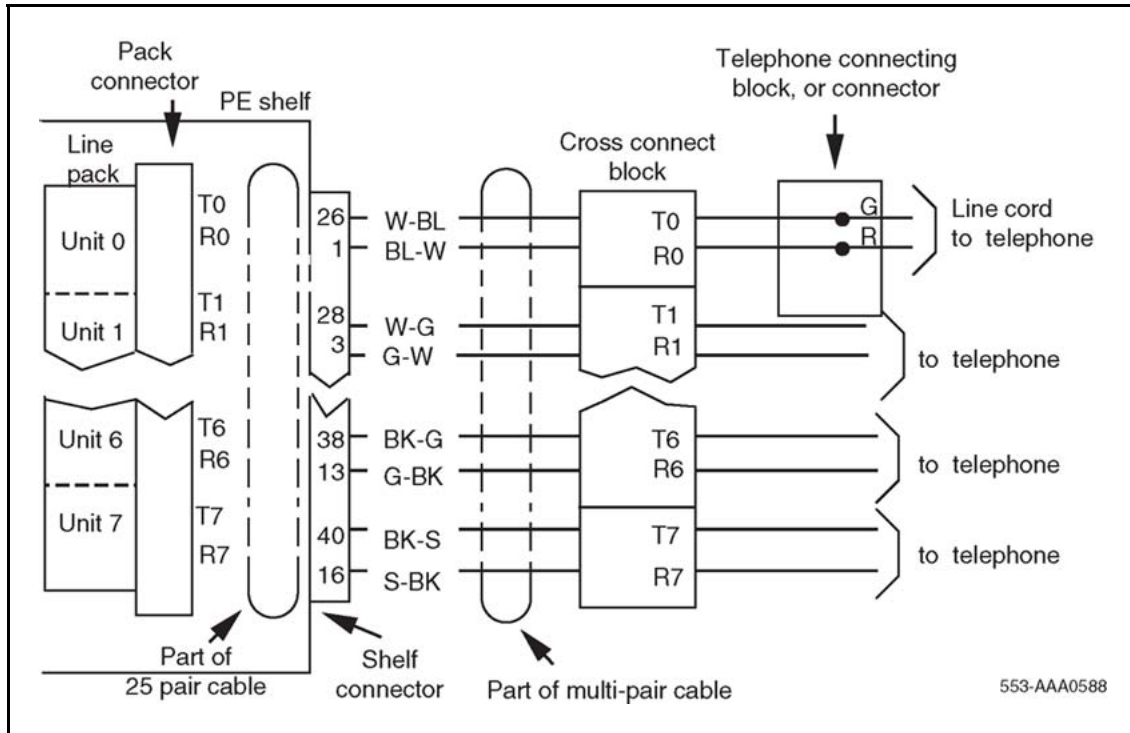

M2317 telephone self-test

The M2317 telephone has a self-testing capability. This test can be performed whether or not the telephone is connected to the system. The test checks the proper functioning of the keys and LCD indicators on the telephone.

Follow the steps listed in [Procedure 64 "Performing the M2317 telephone self-test"](#) (page 292) and [Table 85 "M2317 telephone key/LCD indicator self-tests"](#) (page 293) to perform the M2317 self-test.

Procedure 64 Performing the M2317 telephone self-test

Step	Action
1	Connect the telephone to the AC power supply. The LCD screen displays "Initialization É vX.X" (note that there is only a 3 to 5 second window to begin Step 2).
2	Press Softkey 5 twice, then press Softkey 4 twice.
3	Follow the steps in Table 85 "M2317 telephone key/LCD indicator self-tests" (page 293) to perform the necessary self-test steps and check results.

Table 86
M2317 trouble-locating procedures (cont'd.)

Step	Action
1	<p>If voice communication is normal but data communication fails, check for DC output voltage at the power supply connector pins or replace the power supply plug-in transformer.</p> <p>Attempt to make a data call from the terminal keyboard. Refer to Table 99 "M2317 data features" (page 367). If not successful, proceed with Step 2.</p>
2	<p>Make a call to the DN (voice or data) to verify that the port is enabled.</p>
3	<p>Use an EIA or RS-232 breakout box in conjunction with the terminal cable to verify lead states and replace or repair cable if pinouts are incorrect.</p> <p>Attempt to make a data call from the terminal keyboard. Refer to Table 99 "M2317 data features" (page 367). If unsuccessful, proceed with Step 4.</p>
4	<p>Remove the transformer from the AC receptacle, unplug the 5-pin power supply connector at the back of the telephone, and replace the data option circuit board. See Procedure 78 "Installing the M2317 data option" (page 347). Reconnect the data option power supply.</p> <p>Make a new attempt to start a data call. If trouble persists, continue with the ISDL C failure procedure.</p>
5	<p>Use the self-test procedure to verify that the telephone electronics are operating correctly.</p>
ISDL C failure	
1	<p>Go to the system maintenance terminal (TTY or CRT) and check for displayed error and location codes. An "NWS 401 L S C" or an "NWS 501 L S C U" code indicates that the automatic (routine) diagnostic test has detected a fault.</p> <p>Check for the following indications:</p> <p>L = faulty circuit card (ISDL C card) loop number</p> <p>S = circuit card location (shelf number)</p> <p>C = number of the faulty circuit card</p> <p>U = unit number of a faulty telephone (appears only in conjunction with the NWS 501 code)</p>
2	<p>Replace the faulty components.</p> <p>Try to establish a call. If unsuccessful, check the telephone.</p>
Telephone (voice or dialing) failure	
<p>Note: If no error codes are shown at the maintenance terminal, the Network and Signaling Diagnostic (LD 30) can be loaded and run manually from the system TTY. Refer to <i>Software Input Output Administration (NN43001-611)</i>. ()</p>	

Table 86
M2317 trouble-locating procedures (cont'd.)

Step	Action
1	<p>Check the line cord and handset cord to determine if all TELADAPT connectors are firmly in place and reconnect the loose ones. Ensure that the polarity of the Tip and Ring leads is correct.</p> <p>Lift the handset and listen for the dial tone and/or dial a directory number. If unsuccessful, proceed with Step 2.</p>
2	<p>Wiggle the line cord and/or handset cord while listening for sounds from the handset. If crackling or ticking sounds are heard, replace the cords.</p> <p>Try to establish a call. If unsuccessful, proceed with Step 3.</p>
3	<p>Replace the telephone.</p> <p>Try to establish a call. If unsuccessful, proceed with Step 4.</p>
4	<p>Check the wiring between the line card, distribution panel, and telephone for breaks or loose connections. If necessary, rerun the wiring.</p> <p>Operate the telephone.</p>
<p>Note: If no error codes are shown at the maintenance terminal, the Network and Signaling Diagnostic (LD 30) can be loaded and run manually from the system TTY. Refer to <i>Software Input Output Administration (NN43001-611)</i>. ()</p>	

Designate telephones

Before designating telephones, check the work order for the features enabled and key designations. Designate each key by placing its feature name (from the designation sheet) in the key cap that fits on the key.

Follow the steps in [Procedure 65 "Designating Meridian Modular Telephones"](#) (page 295) to designate Meridian Modular Telephones.

Procedure 65 Designating Meridian Modular Telephones

Step	Action
1	Remove the cap from each key requiring a designation.
2	Place the designation in the cap, place the cap over the corresponding key, and gently press down. Repeat for all keys requiring designations.
3	Insert a paper clip into the hole at the left or right end of the designation window.
4	Gently pry the window toward the center and remove, and insert the number tag.

- 5 Replace the designation window.

--End--

Cross-connect the telephones

Follow the steps in [Procedure 66 "Cross-connecting the telephones"](#) (page 296) to cross-connect the telephones. Refer to [Figure 63 "Meridian Modular Telephone cross-connections"](#) (page 297) for an illustration of cross-connections.

Procedure 66 Cross-connecting the telephones

Step	Action
1	Locate the telephone terminations at the cross-connect terminal. Telephone terminations are located on the vertical side of the frame when frame-mounted blocks are used and in the blue field when wall-mounted blocks are used.
2	Connect Z-type cross-connecting wire to the leads of the telephone. See Table 87 "Z-type cross-connecting wire" (page 296) and Table 88 "Inside wiring colors" (page 297).
3	Locate the line circuit card (TN) terminations. Line circuit card (TN) terminations are located on the horizontal side of the distributing frame when frame-mounted blocks are used and in the white field when wall-mounted blocks are used.
4	Run and connect the other end of the cross-connecting wire to the assigned TN terminal block.

--End--

Table 87
Z-type cross-connecting wire

Size	Gauge	Color	Designation
1 pr	22	Y-BL	Tip
		BL-Y	Ring
3 pr	24	W-BL	Voice T
		BL-W	Voice R
		W-O	Signal T
		O-W	Signal R

Size	Gauge	Color	Designation
		W-G	Power
		G-W	Power

Table 88
Inside wiring colors

Inside wiring colors		Connect to equipment TN
Z station wire	16/25-pair cable	
G	W-BL	First pair Tip
R	BL-W	First pair Ring
BK	W-O	Second pair Tip
Y	O-W	Second pair Ring

Figure 63
Meridian Modular Telephone cross-connections

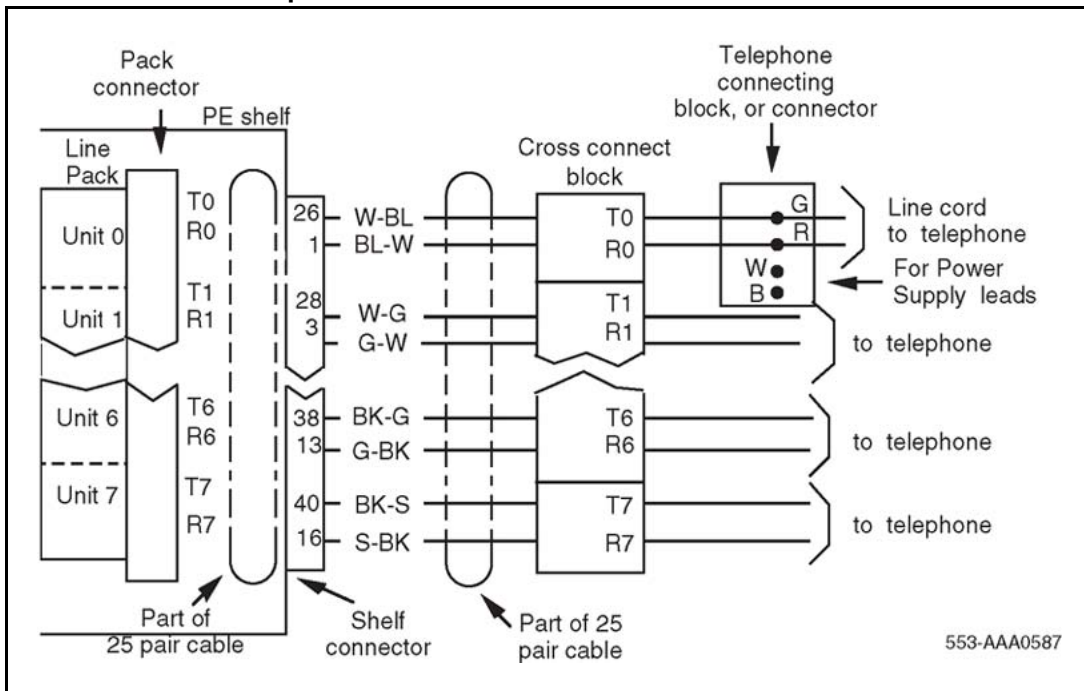

Appendix

Meridian Modular Telephones add-on modules installation

Contents

This section contains information on the following topics:

- “Packing and unpacking” (page 300)
- “Meridian Modular Telephones” (page 300)
- “Analog Terminal Adapter” (page 302)
 - “Functional description” (page 303)
- “Meridian Communications Adapter and Meridian Programmable Data Adapter” (page 308)
 - “Functional description” (page 308)
- “Power Supply Board (NTZK models)” (page 317)
- “Power Supply Board (NT2K models)” (page 324)
- “Installing displays” (page 327)
- “External Alerter Board” (page 337)
- “Key Expansion Modules” (page 340)
- “Asynchronous Data Option” (page 343)
 - “Functional description” (page 343)
 - “ADO operating parameters” (page 344)
 - “ADO external power supply” (page 345)
- “M2317 Data Option” (page 346)
- “Meridian Communications Unit” (page 350)
 - “Functional description” (page 350)

[“Analog Terminal Adapter” \(page 302\)](#)

[“Troubleshooting” \(page 351\)](#)

Note: This section is for reference only. The telephone and options described in this chapter are manufacture discontinued and no longer available.

Packing and unpacking

Use proper care when unpacking any add-on module. Check for damaged containers so that appropriate claims can be made to the transport company for items damaged in transit.

If a module must be returned to the factory, pack it in the appropriate container to avoid damage during transit. Remember to include all loose parts in the shipment.

There are three distinct versions of Meridian Modular Telephones – all three are supported. The versions can be clearly distinguished by the first four letters in the upper left-hand corner of the model identification label on the bottom of the telephone.

The three versions are as follows:

- the "NTZK models
- the "NT2K" models with date code prior to April 24, 1998
- the third version includes both the "NT9K" models and the "NT2K" models with date code of April 24, 1998 and later

In addition, the two jacks face in the same direction on "NT2K" and "NT9K" telephones, and in opposite directions on "NTZK" telephones. When appropriate, differences between the models are noted in this document.

Meridian Modular Telephones

Use the procedures in this section for adding hardware options to the M2006, M2008/M2008HF, M2016S, M2616, and M2216ACD telephones only.



CAUTION

Damage to Equipment

Use only the line cord provided with the Meridian Modular Telephone when installing and removing options. The acceptable line cord is A0346862.

Figure 64 "Exploded view of the M2616/M2016S/M2216ACD telephone" (page 302) on Figure 64 "Exploded view of the M2616/M2016S/M2216ACD telephone" (page 302) shows an exploded view for reference when dismantling the telephone to get to its internal components. Some telephone types are slightly smaller than the M2616 and do not have the center screw in the base, but otherwise they are the same. The center screw may not be required.

Refer to Figure 70 "M2006/M2008 telephone and option boards" (page 319) on Figure 70 "M2006/M2008 telephone and option boards" (page 319) to locate the various components of the M2006 and M2008/M2008HF telephones. Refer to Figure 71 "M2616/M2216ACD telephone and option boards" (page 320) on Figure 71 "M2616/M2216ACD telephone and option boards" (page 320) to locate components on the M2616, M2016S, and M2216ACD telephones.

Figure 64
Exploded view of the M2616/M2016S/M2216ACD telephone

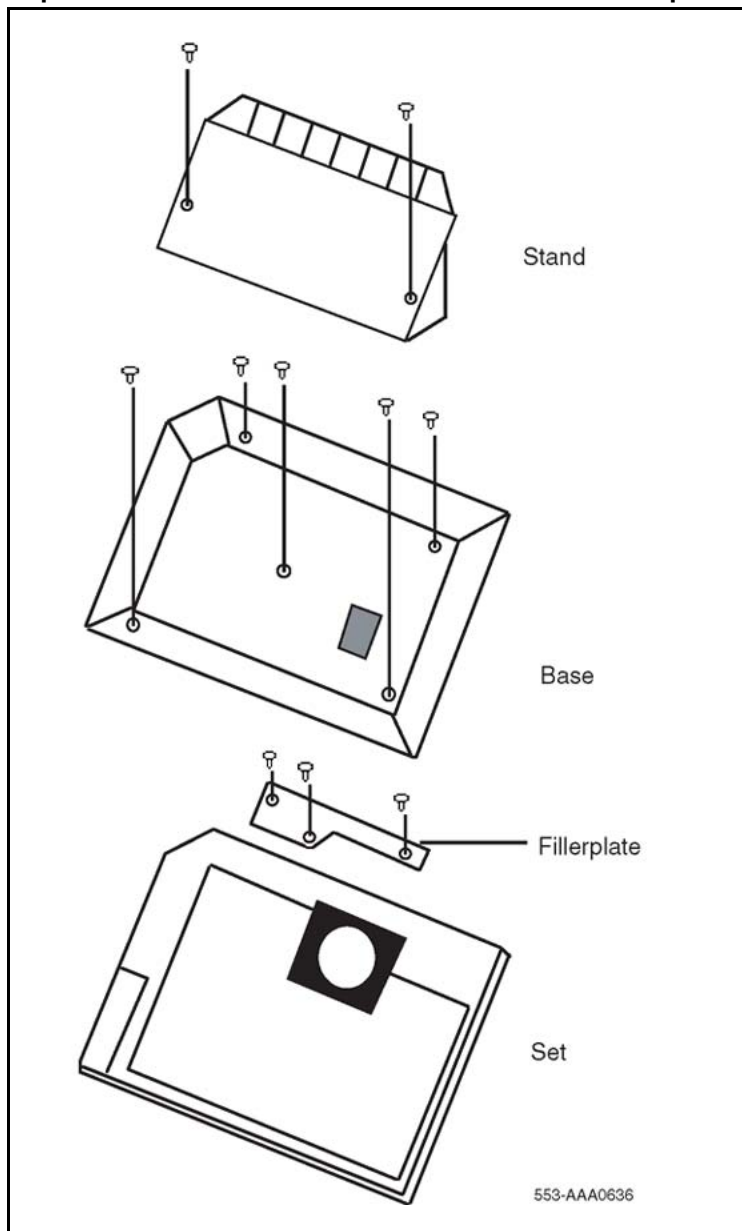

Analog Terminal Adapter

The Analog Terminal Adapter (ATA) enables the use of an off-the-shelf analog device (FAX, Modem, Telephone) to operate simultaneously with the Meridian Digital Telephones. The Analog Terminal Adapter board fits into the footstand space of the Meridian Digital Telephone.

Functional description

The Analog Terminal Adapter is mounted in the footstand of the Meridian Digital Telephone set. The ATA requires a separate AC adapter that provides a 24 V AC external power source. The ATA does not draw power from the Meridian Digital Telephone set.

The Analog Terminal Adapter (ATA) provides a RJ11 connection for analog equipment to operate on the same line as the Meridian Digital Telephone set. The Analog Terminal Adapter enables data to be transmitted and received using the public switched telephone network (PSTN). The ATA supports an analog device link to a desktop or laptop computer (with modems) in the digital telephone environment. Currently, it is necessary to install a separate analog phone line to be able to interface with the PSTN.

The ATA can be used for the following analog devices:

- FAX Machine
- Modem
- Analog Telephone

ATA operating parameters

The ATA data parameters are stored locally, although the configuration is set in the CS 1000 and Meridian 1 system. Do not set data parameters in the system before installing the ATA in the telephone. If the parameters are set before the telephone is installed, the configuration information is lost.

Simultaneous voice and data capabilities are available. When the ATA is installed, the System Administrator must activate the Flexible Voice and Data feature by configuring LD 11. See *Software Input Output Administration (NN43001-611)* () for prompt and response details.

The ATA is capable of receiving dial pulse or DTMF address signaling from the analog equipment.

The ATA uses the 2nd channel of the TCM loop to add an analog port to the digital terminal. It has an RJ11 type jack accessible from the back of the telset.

The analog interface of the ATA is a 2-wire source, providing A and B leads (tip and ring) across which analog equipment (modem/fax) is connected. The loop length is >100 feet. The analog interface of the ATA is compatible with the port types listed in [Table 89 "Port types compatible with ATA" \(page 304\)](#).

Table 89
Port types compatible with ATA

Country	Port Type(s)	Defining Standard(s)
United States	ONS Station Interface	EIA/Tia-464A
	Class A OPS Station Interface	FCC Rules Part 68
Canada	ONS Station Interface	CAN3-T512.1
	Class 1300 OPS Station Interface	CS-03 Part I

Refer to *Analog Terminal Adapter Installation and Reference Guide (NN42370-121)* () for detailed information on this feature.

Follow the steps in [Procedure 67 “Installing and removing the Analog Terminal Adapter”](#) (page 304) on [Procedure 67 “Installing and removing the Analog Terminal Adapter”](#) (page 304) to add the Analog Terminal Adapter (ATA) to the telephone and to connect it to a FAX or modem. The ATA is supported on Meridian Digital Telephones only.

Procedure 67
Installing and removing the Analog Terminal Adapter

	<p>CAUTION CAUTION WITH ESDS DEVICES</p> <p>Before handling internal telephone components, discharge static electricity from hands and tools by touching any grounded metal surface or conductor.</p>
------------------------------------------------------------------------------------	--------------------------------------------------------------------------------------------------------------------------------------------------------------------------------------------------------------------------

Step	Action
1	When the ATA is installed, the System Administrator must activate the Flexible Voice and Data Feature by configuring LD 11.
2	To Activate the Flexible Voice and Data Feature, use the following chart to configure LD 11 (for more detailed information, refer to <i>Software Input Output Administration (NN43001-611)</i> ()).

Table 90
Flexible Voice and Data feature configuration

Prompt	Response	Description
REQ:	NEW/CHG	New or change
TYPE:	aaaa	Telephone type, where aaaa = 2006, 2008, 2016, or 2616
TN		Terminal Number, where u = 16-31
	l s c u	Format for Large System and CS 1000E system, and Media Gateway 1000E, where l = loop, s = shelf, c = card, u = unit.

Table 90
Flexible Voice and Data feature configuration (cont'd.)

Prompt	Response	Description
CLS	c u	Format for Small System, CS 1000S system, Media Gateway 1000B, and Media Gateway 1000T, where c = card and u = unit.
	FLXA	Flexible voice/data allowed. This Class of Service can only be assigned to 2006, 2008, 2016, 2216 or 2617 sets. When configured to CLS=FLXA
	VCE	(FLXD) = Flexible voice/data denied. Voice Class of Service (VCE) can be assigned to the upper TN unit (16-31) and Data class of Service (DTA) can be assigned to the lower TN (0-15). A Single Call Ringing (SCR) key can be designated a Data Mode (DTNK) key.
KEY		Prime Directory Number Key, SCR, SCN, MCR or MCN and xxx.
-Key	xx SCR yyyy	Single Call Ringing
	xx SCN yyyy	Single Call Non Ringing Data Mode Key, where xx = key number and yyy = Data Directory Number.

- 3 Disconnect and remove all cords (including the handset cord) from the telephone.
- 4 Place the telephone, face-down, on a padded level surface.
- 5 Using a #1 Phillips screw driver, remove both screws and separate the footstand from the phone base.
- 6 If using the NT9K ATA ready set or the NT2K with date code of April 24, 1998 or later:
 - Remove and retain the footstand (this footstand will be reattached back onto the set base after ATA installation is complete).
 - Skip to the ATA Installation [Step 13](#).
- 7 If using the NT2K or the NTZK phone set, remove and discard the footstand. Use the redesigned footstand required for the installation of the ATA.
- 8 If an MCA or MPDA installed is installed, unplug it from the data line jack in the phone base.
- 9 Remove the back covering of the phone base by removing the four screws.

Figure 65
Telephone base and footstand

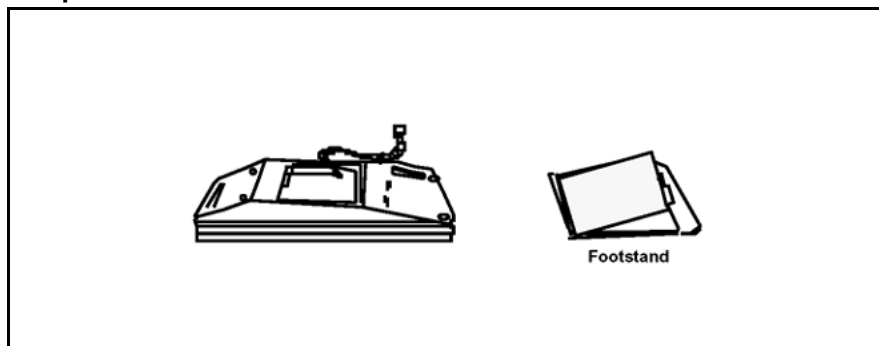

- 10 If the phone is equipped with a Power Option board and/or cable, you must remove it before installing the ATA. The Power Option board is located on the left side of the telephone:
- Remove the two small screws from the Power Option board (near the top) and set them aside.
 - To disconnect the Power Option board from the **NTZK** telephone, grasp the board firmly on each side and slowly rock the Power Option board while applying upward pressure until it is released from the 2X7 pin connector.
 - To disconnect the **NT2K** Power Option board from the set simply remove the screws from the Power Option board and base and lift the board out of the set.
 - If the Power Option board has a ribbon cable, disconnect the cable from the 2X7pin connector on the main board and remove the cable

Figure 66
Connector view

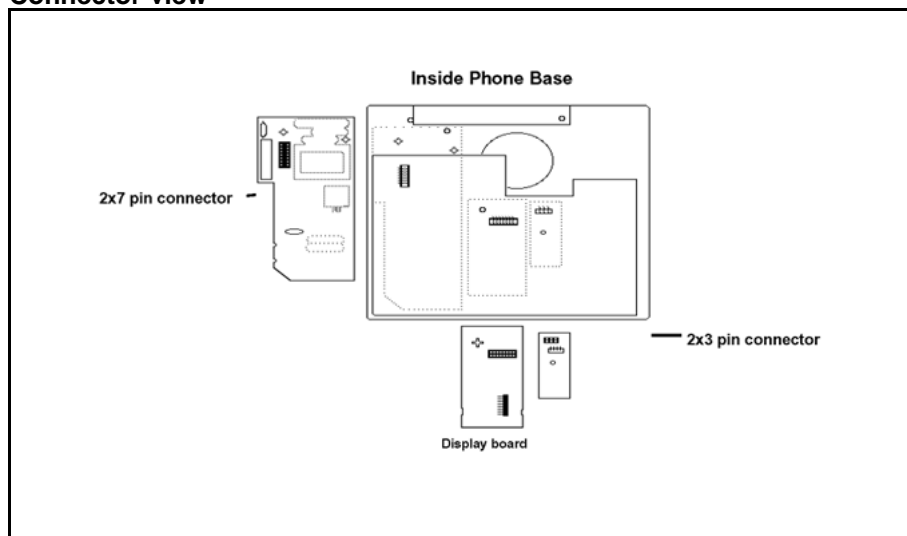

- 11 If the phone is equipped with the External Alerter Option, remove it before installing the ATA. The External Alerter Option board is located at the right center of the telephone:
 - Remove the screws from the External Alerter Option board.
 - Grasp the board firmly on each end and pull upward to remove from the 2X3 pin connector
- 12 Install the Jumper board on the 2X7 pin connector inside the phone set base.
 - There are 2 Jumper boards provided. Use the brown Jumper board for the NTZKxxxx phone set and the black Jumper board for the NT2Kxxxx phone set with a date code prior to April 24, 1998.
 - If a Power Option board was not installed on the NT2Kxxxx and the NTZKxxxx there will be 2 Jumper plugs on the 2X7 pin connector that must be removed before installing the Jumper board.
- 13 Remove the knockout located on the back panel of the footstand in order to install the ATA. It is the smaller knockout, located inside the large knockout. The small ATA knockout can be remove by pressing it in with thumb presser.
- 14 Install the ATA Printed Circuit board into the footstand.
- 15 Plug the ATA 8-conductor line cord, included in the package, into the data jack in the base of the telephone. Plug the other end of this cord into the data jack of the ATA located in the footstand.
- 16 Reassemble the footstand on the base and screw it into position using a #1 Phillips screwdriver.
- 17 Plug the 24v AC Power Transformer into the circular mini DIN connector on the backpanel of the footstand.
- 18 Plug the transformer end of the AC Power Transformer into the AC commercial electrical outlet.
- 19 The analog device can now be connected to the RJ11 connector on the back of the footstand. Refer to the manufacturer's documentation for installation instructions for the FAX, modem, or telephone to be used.

--End--

Meridian Communications Adapter and Meridian Programmable Data Adapter

The Meridian Communications Adapter (MCA) replaces the Meridian Programmable Data Adapter (MPDA), and offers enhanced capability over the MPDA.

Functional description

The MCA mounts within the telephone. It enables synchronous and asynchronous ASCII terminals and personal computers to be connected to the telephone using an RS-232-C or V.35 interface on a DB-25 connector. See [Figure 67 "Back of telephone showing MCA" \(page 311\)](#).

The MCA enables synchronous applications (DTEs such as video conferencing equipment and Group IV fax units) to be connected to the telephone. System software enables access to data functions through both the keypad and service change in LD 11.

Asynchronous mode features supported by the MCA include the following:

- Asynchronous transmission at up to 19.2 kbps (autobaud)
- Enhanced Hayes commands, including upper- and lower-case dialing, voice call origination through AT dialing, hang-up data call, and on-line disconnect of voice call
- Script file capability that enables the MCA to learn a dial-up and log-on sequence that can be played back to automatically access a host or service
- Voice Call Origination (VCO)
- DCE mode
- Autodial
- Ring Again
- Speed Call
- Autobaud and Autoparity Detect
- Modem Pool Calling
- Host/Terminal Mode
- Forced Data Terminal Ready (DTR)
- Dynamic Carrier Detect (DCD)
- Inactivity Time-out
- Remote Loopback
- RTS/CTS hardware flow control capability (when calling another MCA)

Synchronous mode features supported by the MCA include the following:

- Half Duplex/Full Duplex
- Internal and external clocking
- Modem and network capability
- Synchronous transmission up to 64 kbps
- Public Switched Data Service (PSDS) compatibility. MCA extends PSDS and 64K restricted and 64K clear capabilities to Modular telephones.
- V.25 bit dialing protocol support at all synchronous speeds up to 64 kbps. High-Level Data Link Control (HDLC) and Bisynch (character oriented) framing of the V.25 commands are supported.
- Programmable echo canceller disabling for 56 and 64 kbps network calls

Synchronous *and* asynchronous mode features supported by the MCA include the following:

- T-Link and DM-DM support
- T-Link and DM-DM are Nortel proprietary protocols. The SL-100 and DMS data devices use T-Link. DM-DM is used by CS 1000 and Meridian 1 data devices such as ASIM, AIM, ADM, SADM, Asynchronous Data Option (ADO), and MPDA. MCA can use both DM-DM and T-Link.
- Hotline
- Virtual Leased Line
- V.35 interface capability selectable with jumper plugs on the MCA
- Data tandem calls across TIE trunks, provided all switches involved are Nortel machines
- PSDS tandem data calls across TIE trunks are supported with release 18 or later when each tandem node uses an ISDN Primary Rate Interface (PRI) or Basic Rate Interface (BRI) connection.

Note: Internal PSDS calls are not supported.

MCA operating parameters

The MCA data parameters are stored locally, although the configuration is set in the system. Data parameters cannot be set in the system before installing the MCA in the telephone. If the parameters are set before the telephone is installed, the configuration information is lost.

Operating parameters are downloaded after the MCA is enabled in LD 11. System parameters are downloaded when the MCA is configured in LD 11, and power is reset. See *Software Input Output Administration (NN43001-611)* () for prompt and response details.

Data parameters can also be set through LD 11, as well as by the keypad.

The MCA communicates with Data Terminal Equipment (DTE) using the operating parameters shown below.

Synchronization	Asynchronous, Start-Stop
Number of bits	8 bits
Parity	none (unchecked)
Data rate	110, 150, 300, 1200, 2400, 4800, 9600, 19200 bits per second (autobaud) asynchronous up to 64000 bits per second synchronous
Stop bits	2 bits for 110 bits per second; 1 bit for all other speeds (asynchronous only)
Transmission	Half duplex; full duplex

When using the MCA for synchronous data connections, configure the telephone with a display option to view the data parameters. The MPDA and MCA are supported on Meridian Modular Telephones only.

When installing an MCA or MPDA into NTZK or NT2K phone sets with a date code prior to January 1998, a Power Option board is required, along with an additional power source.

When installing an MCA in an NT9K or NT2K phone set with date code of January 1998 or later, install only the MCA. An additional Power Option board and Jumper board is not required. See [Table 79 "NT2K model Power requirements, Meridian Modular Telephone sets" \(page 278\)](#) for power requirements information.

- See [Procedure 70 "Installing and removing the M2006/M2008 Power Supply Board on NTZK sets" \(page 317\)](#) for M2006/M2008 NTZK sets.
- See [Procedure 71 "Installing and removing the M2616/M2216ACD Power Supply Board on NTZK sets" \(page 320\)](#) for M2616/M2216ACD NTZK sets.

- See Procedure 72 “Installing and removing the M2006 or M2008 Power Supply Board on NT2K sets” (page 325) for M2006/M2008/M2008HF NT2K sets.
- See Procedure 67 “Installing and removing the Analog Terminal Adapter” (page 304) for installing an MCA onto an NT9K or NT2K with date code of April 24, 1998 and later.

Figure 67 “Back of telephone showing MCA” (page 311) on Figure 67 “Back of telephone showing MCA” (page 311) shows the back of a Modular telephone with an MCA mounted; Figure 68 “Block diagram of MCA and Modular telephone” (page 312) on Figure 68 “Block diagram of MCA and Modular telephone” (page 312) shows a block diagram of the Modular telephone and MCA.

Figure 67
Back of telephone showing MCA

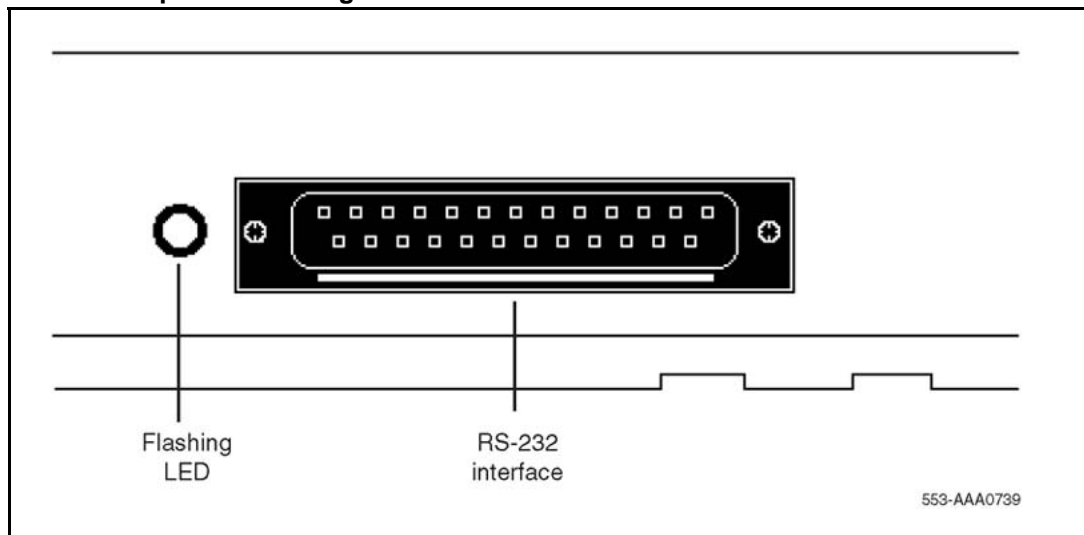

The MCA can be placed as far from its associated data terminal or computer port as is consistent with EIA RS-232 or V.35.

When the MCA is used as a V.35 interface, an additional cable is required to convert the DB-25 into a 34-pin rectangular connector. This does not apply to asynchronous configurations. If the pins are left in V.35 mode, asynchronous operation is not supported, and the MCA looks as though it is locked up.

Figure 68
Block diagram of MCA and Modular telephone

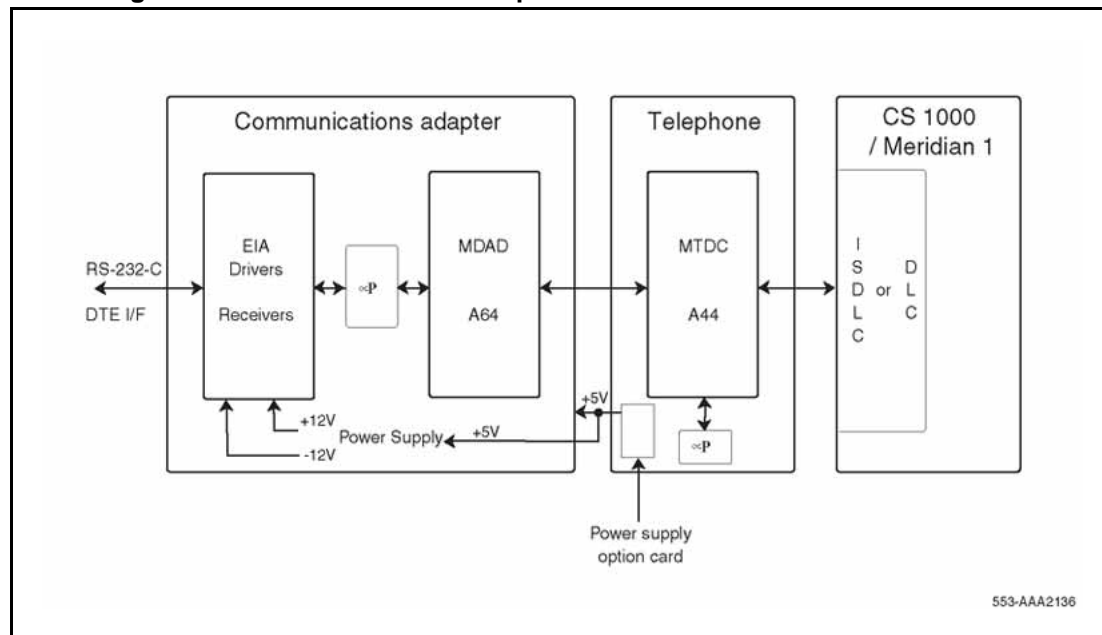

Remove the two 14-pin jumper plugs or one 20-pin jumper plug inside the MCA from the RS-232 socket(s) and install the V.35 socket.

Note: The female cable ordering code is A0408927. The male cable ordering code is A0408928. The A0300752 and A0300753 cables are still supported, unless used with applications similar to IBM front-end.

Modem pooling is not supported on the MCA.

When a call is connected between two MCAs, and power is removed from one, the MCA does not release until the power is restored.

The MCA always remembers the most recent data parameters. In the case of power failure, data settings do not have to be reset.

See [Table 91 "V.35 CCITT signals supported by the MCA" \(page 313\)](#) for a listing of the V.35 CCITT signals supported by the MCA.

Table 91
V.35 CCITT signals supported by the MCA

V.35 CCITT	MCA DB-25 pin no.	Abbr.	Adaptor cable		Signal Source		Description
			DB-25 Pin No.	V.35 Pin No.	DTE	MCA	
101	1	DG	1	A			Protective ground*
103A	2	SDA	2	P	X		Transmit data A
104A	3	RDA	3	R		X	Receive data A
105	4	RTS	4	C	X		Request to send
106	5	CTS	5	D		X	Clear to send
107	6	DSR	6	E		X	Data set ready
102	7	S	7	B			Signal ground
109	8	CD	8	F		X	Carrier detect
—	9/10	—	9/10	CC/L			No connection
—	11	—	11	K	X		**
115B	12	SCRIB	12	X		X	Serial clock receive B
103B	13	SDB	13	S	X		Transmit data B
114B	14	SCTB	14	AA		X	Serial clock transmit B
114A	15	SCTA	15	Y		X	Serial clock transmit A
104B	16	RDB	16	T		X	Receive data B
115A	17	SCRA	17	V		X	Serial clock receive A
—	18/19	—	18/19	M/HH			No connection
108.2	20	DTR	20	H	X		Data terminal ready
—	21	—	21	EE			No connection
125	22	RI	22	J		X	Ring indicator
113B	23	SCTEB	23	W	X		Tran sign elemt time B
113A	24	SCTEA	24	U	X		Tran sign elemt time A
—	25	—	25	MM	X		**

Note: * Pin 1 is connected to the MCDS shelf frame.
** These leads are ignored by the MCA controller.

Use the following procedures to add the Meridian Communications Adapter (MCA) or Meridian Programmable Data Adapter (MPDA) to the telephone and to connect it to a terminal or personal computer.

See the *Meridian Communications Adapter User Guide* () for more information on MCA operation.



CAUTION
CAUTION WITH ESDS DEVICES

Before handling internal telephone components, discharge static electricity from hands and tools by touching any grounded metal surface or conductor.

Procedure 68
Installing and removing the Meridian
Communications Adapter or the Meridian
Programmable Data Adapter

Step	Action
------	--------

If using a NT9K phone or the NT2K with date code of April 24, 1998 and later, it is not necessary to install a Power Option board to operate the MCA.

- | | |
|---|-----------------------------------------------------------------------------------------------------------------------------------------------------------------------------------------------------------------------------------------------------------------------------------------------------------------------------------------------------------------------------------------------------------------------------------------------------------------------------------------------------------------------------------|
| 1 | Remove the handset and place the telephone upside down on top of a level, solid work surface (a desktop, for example) covered with soft material or paper to prevent damage to movable keys and the telephone face. |
| 2 | Disconnect all cords from the telephone. |
| 3 | Remove the footstand. <ul style="list-style-type: none"> • For NT2K and NTZK with date code prior to April 24, 1998 remove the two screws from the footstand assembly and unsnap the footstand by pressing inward at the back of the footstand where it meets the base and pull upward. Discard the footstand. The redesigned footstand ordered with the ATA is used instead. • For NT9K and NT2K with a date code of April 24, 1998 and later, retain the footstand and skip to Step 10. |
| 4 | If the telephone is not equipped with the Meridian Programmable Data Adapter (MPDA) or Meridian Communications Adapter (MCA), go to Step 6 . If replacing an existing MPDA or MCA, carefully disconnect the end of the 8-pin TELADAPT jack plugged into the telephone by pressing firmly on the latch-tab and slowly lifting up. |
| 5 | Turn the telephone footstand assembly over and put it in the normal use position. Remove the two self-tapping screws that fasten the MPDA or MCA to the telephone footstand assembly and remove the MPDA or MCA by pulling outward and up. Go to Step 11 to replace the MPDA or MCA. |
| 6 | Remove the back covering of the phone base by removing the four screws. |
| 7 | If the NTZK or the NT2K (with date code prior to April 24, 1998) phone set is equipped with a Power Option board and/or cable, the Power Option board and/or cable must be removed before installing the MCA. |

- Remove the two small screws from the Power board (near the top) and set them aside.
 - To disconnect the Power Option board from the NTZK telephone, grasp the board firmly on each side and slowly rock the board while applying upward pressure, until it is released from the 2X7 pin connector.
 - To disconnect the NT2K Power Option board from the set, simply remove the screws from the base and lift the board out of the set.
 - If the Power Option board has a ribbon cable disconnect the cable from the 2X7 pin connector on the main board and remove the cable.
- 8** If the phone is equipped with the External Alerter board, it must be removed before installing the MCA with redesigned footstand.
- The External Alerter board is located at the right center of the telephone.
 - Remove the screws form the board, grasp the board firmly on each end and pull upward to remove it from the 2X3 pin connector.
- 9** Install the Jumper board onto the 2X7 pin connector inside the phone base.
- If the phone set did not have a Power Option board installed on the NT2K or the NTZK then there will be 2 Jumper plugs on the 2X7 connector. Remove them before installing the Jumper board.
 - The redesigned footstand will have 2 jumpers. Use the black one for the NT2K phone and the brown one for the NTZK phone.
- 10** Remove the large MCA knockout section in the rear of the telephone footstand assembly, and remove the small tabs. See [Figure 69 "Installing the MCA" \(page 316\)](#). It is best to remove this knockout with a screwdriver.
- 11** For MCA, set option plugs to the required configuration, RS-232 or V.35. The factory default is RS-232.

Figure 69
Installing the MCA

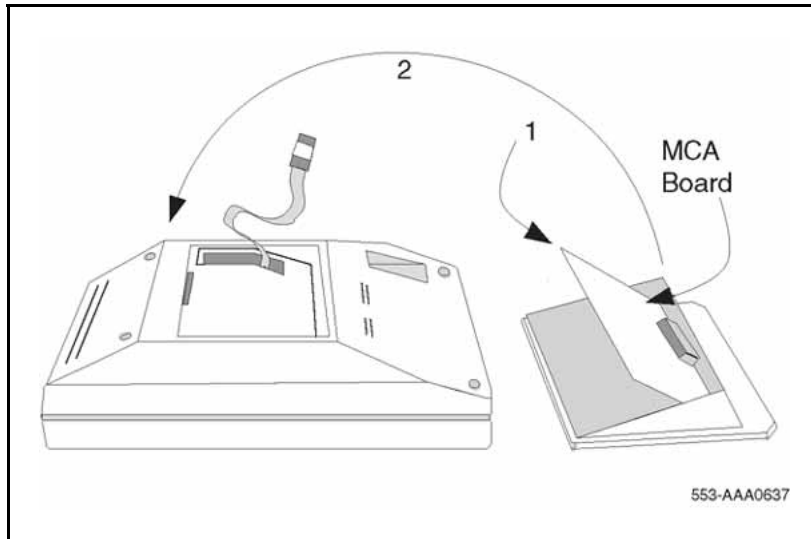

- 12** Tilt the MPDA or MCA circuit board up and insert the DB-25 connector socket into the breakout section. Then slide the board connector end-first under the tabs in the footstand assembly and position it over the locating pins. Position and lower it completely onto the telephone footstand assembly. Insert the two self-tapping Phillips-head screws supplied with the MPDA or MCA into the mounting holes and tighten them with a #1 Phillips screwdriver.
- 13** Plug one end of an 8-conductor line cord supplied with a TELADAPT adapter in the jack J1 of the MPDA or MCA (latch tab facing down) and plug the other end of the line cord into the data jack in the base of the telephone. Make certain the latch tab of each cable end is firmly snapped into place.
- 14** Carefully route the excess cable so that it will not become pinched between the footstand and base.
- 15** Reassemble the base and footstand assembly sections, ensuring that the footstand is firmly seated on the base.
- 16** Tighten the screws
- Reconnect all cords, connect the new 24v AC transformer to the set.
 - Plug in the new transformer into the 110v AC commercial electrical outlet.
 - Place the telephone in the normal operating position.

Note 1: Place the label supplied with the MPDA or MCA on the outside of the bottom cover of the telephone. This allows proper identification and tracking of the option level of the set.

Note 2: If an ADM3, ADM5, or ADM11 terminal is used in conjunction with the DB-25 connector-C interface connector in the Asynchronous Programmable Data Adapter, pin 22 in the DB-25 connector cable must be disconnected. These ADM terminals will go into test mode if this pin is not disconnected.

--End--

Procedure 69
Connecting the data terminal

Step	Action
1	Connect the DB-25 connector-C interface connector from the data terminal to the matching header connector in the back of the telephone.
2	Insert the two captive screws in the connector body into the threaded holes in the header connector and secure tightly to prevent accidental disconnection during data terminal operation.

--End--

Power Supply Board (NTZK models)

Use the following procedures to add a Power Supply Board to the telephone for connection to a transformer or closet power supply. Use [Procedure 70 "Installing and removing the M2006/M2008 Power Supply Board on NTZK sets" \(page 317\)](#) for the M2006 and M2008. Use [Procedure 71 "Installing and removing the M2616/M2216ACD Power Supply Board on NTZK sets" \(page 320\)](#) for the M2616 and M2216ACD.

Procedure 70
Installing and removing the M2006/M2008
Power Supply Board on NTZK sets



CAUTION

Damage to Equipment

Connect the optional Power Supply to the Meridian Modular Telephones only. Equipment damage may result from incorrect connections. Both the closet power supply and the transformer are for use with the Meridian Modular Telephones only.



CAUTION

CAUTION WITH ESDS DEVICES

Before handling internal telephone components, discharge static electricity from hands and tools by touching any grounded metal surface or conductor.

Step	Action
1	Remove the handset and place the telephone upside down on top of a level, solid work surface (such as a desktop) covered with soft material or paper to prevent damage to movable keys and the telephone face.
2	Disconnect all cords from the telephone.
3	Remove the two screws from the footstand assembly and unsnap the footstand assembly by pressing inward at the back of the footstand where it meets the base and pulling upward.
4	If the telephone is equipped with a Meridian Programmable Data Adapter (MPDA) or Meridian Communications Adapter (MCA), unplug the data cable from telephone's base jack.
5	Remove the four screws securing the base of the telephone to the top cover. Remove the base and set it aside.
6	If the telephone is equipped with a display, disconnect the display ribbon cable from the display board and move it out of the way.
7	If the telephone is not equipped with the power supply board, remove the jumpers from P1 connector pins on the main board. Go to Step 9 . If the telephone is equipped with a power supply board, go to Step 8 .
8	The power supply board is located on the left side of the telephone. Remove two small screws from the power supply board (near the top) and set them aside. Grasp the board firmly on each side. Work the board loose from the connector by slowly applying upward pressure to alternate sides until released. If the power supply board is not being replaced, place the jumpers (A0288529) connecting the bottom two sets of pins on the P1 connector.
9	Place the power supply board so that the alignment pin on the telephone fits into Slot A on the board. See Figure 70 "M2006/M2008 telephone and option boards" (page 319) on Figure 70 "M2006/M2008 telephone and option boards" (page 319) and Figure 71 "M2616/M2216ACD telephone and option boards" (page 320) on Figure 71 "M2616/M2216ACD telephone and option boards" (page 320) . Align the mounting holes in the board (near the top) over the mounting holes in the telephone and carefully press down so that the H1 connector on the board slides onto the P1 pins.
10	Take the self-tapping Phillips-head screws supplied with the power supply board and install them into the mounting holes. Tighten firmly with a #1 Phillips screwdriver.

- 11 If the telephone has a display, reconnect the display ribbon cable, routing the cable as described in [Procedure 73 “Installing and removing the M2616/M2216ACDDisplay on NTZK sets”](#) (page 327).

Note: Do not allow R5 on the power supply board to become bent during this procedure.

- 12 Replace the base. If the telephone is equipped with an MPDA or MCA, reconnect the data cable to the base telephone jack and replace the footstand (ensuring that the MPDA or MCA cable does not get pinched between the base and footstand). Make sure the footstand is firmly seated to the base.

Note: Place the label supplied with the power supply board on the outside of the bottom cover of the telephone. This allows proper identification and tracking of the option level of the set.

- 13 Tighten all screws, reconnect the line cord, and place the telephone in the normal operating position.

Figure 70
M2006/M2008 telephone and option boards

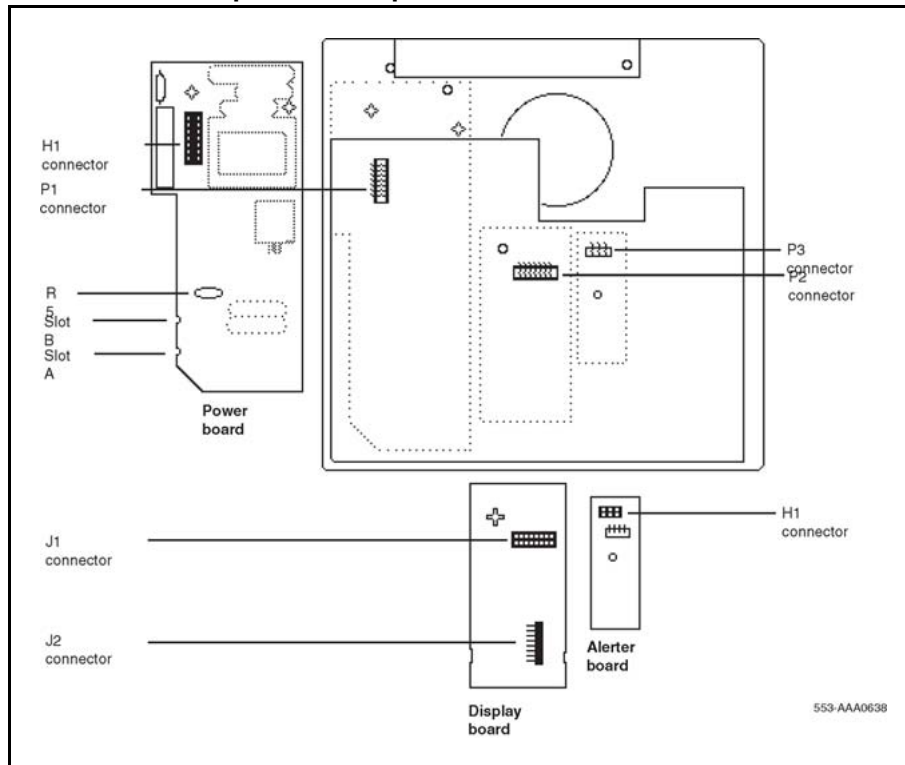
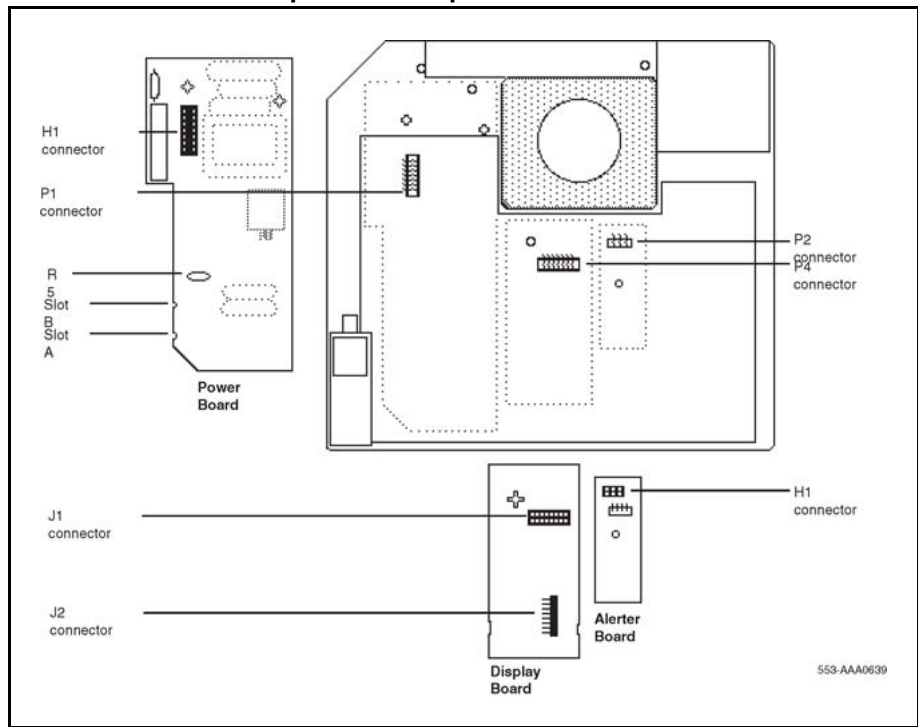



Figure 71
M2616/M2216ACD telephone and option boards



--End--

Procedure 71
Installing and removing the M2616/M2216ACD
Power Supply Board on NTZK sets

	<p>CAUTION CAUTION WITH ESDS DEVICES</p> <p>Before handling internal telephone components, discharge static electricity from hands and tools by touching any grounded metal surface or conductor.</p>
-------------------------------------------------------------------------------------	--------------------------------------------------------------------------------------------------------------------------------------------------------------------------------------------------------------------------

Step	Action
1	Remove the handset and place the telephone upside down on top of a level, solid work surface (such as a desktop) covered with soft material or paper to prevent damage to movable keys and the telephone face.
2	Disconnect all cords from the telephone.
3	Remove the two screws from the footstand assembly and unsnap the footstand assembly by pressing inward at the back of the footstand where it meets the base and pulling upward.

- 4 If the telephone is equipped with an MPDA or MCA, unplug the data cable from the base telephone jack.
- 5 Remove the four or five screws securing the base to the top cover. Remove the base and set it aside.
- 6 If the telephone is equipped with display, disconnect the Display ribbon cable from the display board and move it out of the way.
- 7 If the telephone is not equipped with a power supply board, remove jumpers from the P1 connector pins on the main board. Go to [Step 9](#).

If the telephone is equipped with a power supply board, go to [Step 8](#).
- 8 The power supply board is located on the left side of the telephone. Remove two small screws from the power supply board (near the top) and set them aside. Grasp the board firmly on each side. Work the board loose slowly until it is released.

If not replacing the power supply board, place the jumpers (A0288529) connecting the bottom two sets of the pins on the P1 connector.
- 9 Place the power supply board so that Slot B fits into the alignment pin on the telephone. See [Figure 69 "Installing the MCA" \(page 316\)](#) on [Figure 69 "Installing the MCA" \(page 316\)](#). Align the mounting holes in the board (near the top) over mounting holes in the telephone and carefully press down so that the H1 connector on the board slides onto the pins of the header (P1 on the M2616 or J2 on the M2006/M2008).
- 10 Take the self-tapping Phillips-head screws supplied with the power supply board and install them into the mounting holes. Tighten firmly with a #1 Phillips screwdriver.
- 11 If the telephone has a display, reconnect the display ribbon cable, routing the cable as described in [Procedure 73 "Installing and removing the M2616/M2216ACDDisplay on NTZK sets" \(page 327\)](#) on [Procedure 73 "Installing and removing the M2616/M2216ACDDisplay on NTZK sets" \(page 327\)](#).

Note: Do not allow R5 on the power supply board to become bent during this procedure.
- 12 Replace the base. If the telephone is equipped with an MPDA or MCA, reconnect the data cable to the base telephone jack and replace the footstand (ensuring the MPDA or MCA cable does

not get pinched between the base and footstand). Make sure the footstand is firmly seated to the base.

Note: Place the label supplied with the power supply board on the outside of the bottom cover of the telephone. This allows proper identification and tracking of the option level of the set.

- 13 Connect the telephone to a local transformer (see [Figure 72 "Configuration of a local plug-in transformer" \(page 323\)](#) on [Figure 72 "Configuration of a local plug-in transformer" \(page 323\)](#)) or closet power supply (see [Figure 73 "Closet power supply configuration" \(page 324\)](#) on [Figure 73 "Closet power supply configuration" \(page 324\)](#)). Refer to "Power requirements" ([page 276](#)) for requirements.

--End--

Figure 72
Configuration of a local plug-in transformer

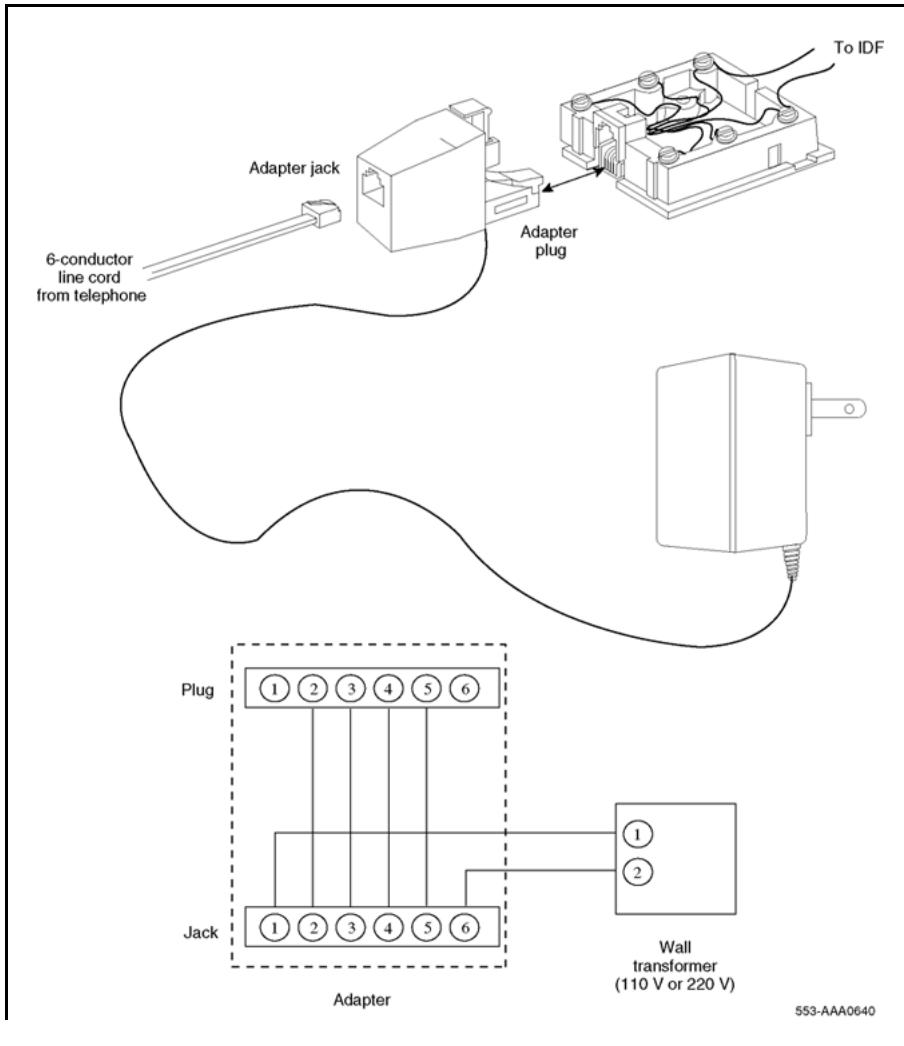
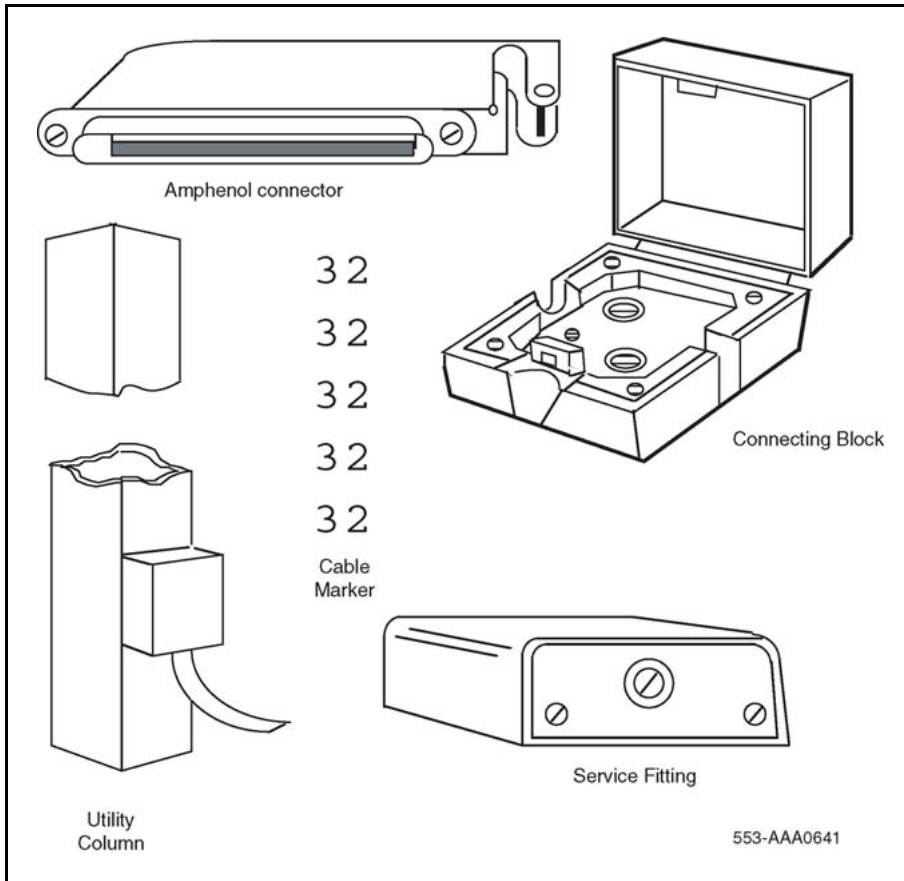



Figure 73
Closet power supply configuration



Power Supply Board (NT2K models)

Follow the steps in [Procedure 72](#) “Installing and removing the M2006 or M2008 Power Supply Board on NT2K sets” (page 325) to add a Power Supply Board to the telephone for connection to a transformer or closet power supply. This procedure applies to the M2006, M2008/M2008HF, M2216ACD and M2616 Meridian Modular telephones, NT2K models.

	<p>CAUTION</p> <p>Damage to Equipment</p>
	<p>Connect the optional Power Supply to the Meridian Modular Telephones only. Equipment damage may result from incorrect connections. Both the closet power supply and the transformer are for use with the Meridian Modular Telephones 2000 Series Meridian Digital Telephone only.</p>



CAUTION
CAUTION WITH ESDS DEVICES

Before handling internal components of telephones, discharge static electricity from hands and tools by touching any grounded metal surface or conductor.

Procedure 72
Installing and removing the M2006 or M2008
Power Supply Board on NT2K sets

Step	Action
------	--------

Opening the Telephone

- | | |
|---|------------------------------------------------------------------------------------------------------------|
| 1 | Disconnect and remove all cords (including the handset) from the telephone. |
| 2 | Place the telephone, upside-down, on a padded, level surface. |
| 3 | If the telephone does not have an MCA or MPDA adapter, go to Step 7 . |
| 4 | Using a #1 Phillips screwdriver, remove both screws from the footstand. |
| 5 | Remove the footstand from the base by pressing in the back of the footstand as it is lifted from the base. |
| 6 | Unplug the MCA or MPDA from the data line jack on the base, and set the footstand aside. |
| 7 | Remove all screws on the base of the telephone. |
| 8 | Remove the base from the telephone. |

Attaching the Power Module

- | | |
|----|--------------------------------------------------------------------------------------------------------------------------------------------------------------------------------------------------------------------------------------------------------|
| 9 | Lay the Power Module assembly into position on the left side of the telephone. Be careful not to bend R5 (the big disk) on the Power Module during installation. |
| 10 | If you are adding a Power Module to the set for the first time (not replacing an existing Power Module), the connector (J2 on the M2006 and M2008/M2008HF, P1 on the M2616) on the main board should have jumpers which must be removed at this point. |
| 11 | Connect the Power Module to the main board with the ribbon cable, keeping the red edge of the ribbon cable from the front of the telephone as show in Figure 74 "Ribbon cable placement" (page 326). |



CAUTION
Damage to Equipment

This is a polarity-sensitive connection. The cable and the connector on the main board (J2 on the M2006 and M2008/M2008HF, and P1 on the M2616) are keyed.

- 12 Screw the Power Module into position on the left side of the telephone.

Figure 74
Ribbon cable placement

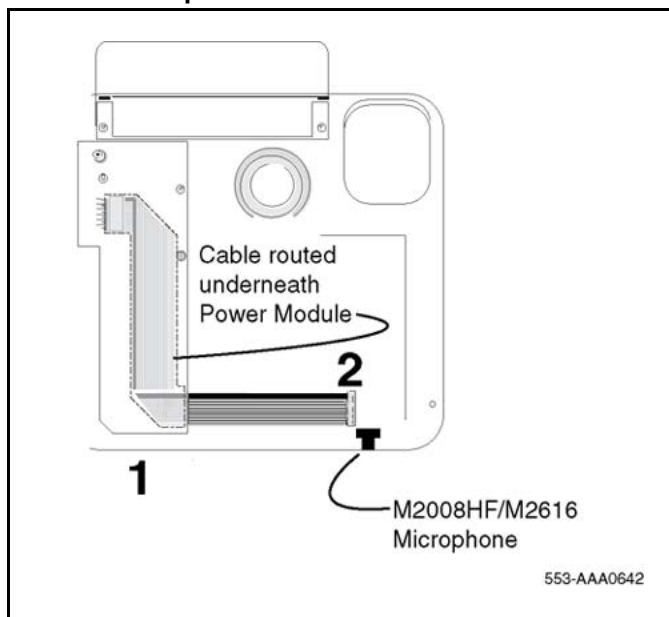

Reattaching the Base

- 13 Make sure that all ribbon cables are lying flat and not caught on any posts on the telephone cover or base.



CAUTION

For the M2616 and M2008HF, make sure that the microphone has not been moved from its black rubber holder. The holder should be seated in the main board near the ribbon cable that was just attached.

- 14 Replace the base.
- 15 Insert all screws and tighten them.
- 16 If the telephone has an MCA or MPDA, plug its cable into the jack on the telephone base.
- 17 Install the footstand, and secure it with two screws.
- 18 Reconnect all cords, including the handset.

Note: Place the label supplied with the power supply board on the outside of the bottom cover of the telephone. This allows proper identification and tracking of the option level of the set.

--End--

Installing displays

The following procedures cover installation of the various displays on the various sets.

- Procedure 73 “Installing and removing the M2616/M2216ACDDisplay on NTZK sets” (page 327): Procedure 73 “Installing and removing the M2616/M2216ACDDisplay on NTZK sets” (page 327)
- Procedure 74 “Installing and removing the M2616 Display on NT2K sets” (page 329): Procedure 74 “Installing and removing the M2616 Display on NT2K sets” (page 329)
- Procedure 75 “Installing NT2K28AA displays on NTZK or NT2K sets” (page 332): Procedure 75 “Installing NT2K28AA displays on NTZK or NT2K sets” (page 332)

Procedure 73 Installing and removing the M2616/M2216ACD Display on NTZK sets



CAUTION **CAUTION WITH ESDS DEVICES**

Before handling internal components of telephones, discharge static electricity from hands and tools by touching any grounded metal surface or conductor.

Step	Action
1	Remove the handset and place the telephone upside down on top of a level, solid work surface covered with soft material or paper to prevent damage to movable keys and the telephone face.
2	Disconnect all cords from the telephone.
3	Remove the two screws from the footstand assembly and unsnap the footstand assembly by pressing inward at the back of the footstand where it meets the base and pulling upward.
4	If the telephone is equipped with an MPDA or MCA, unplug the data cable from the base telephone jack. Remove the five screws securing the base to the telephone. Remove the base and set it aside.
5	If the telephone is not equipped with a display, go to Step 9 . If the telephone is equipped with a display, go to Step 6 .

Removing the display board

- | | |
|---|----------------------------------------------------------------------------------------------------------------------------------------------------------------------------------------------------------------------------------------------------------------------------------------------|
| 6 | The display board is located at the left center of the telephone. Disconnect the display ribbon cable from the display board. Remove the small mounting screw from the board. Grasp the board firmly on each end and pull upward to remove it. To replace it, go to Step 9 . |
|---|----------------------------------------------------------------------------------------------------------------------------------------------------------------------------------------------------------------------------------------------------------------------------------------------|

Removing the display

- 7 The power supply board is located on the left side of the telephone. Remove the two small screws from the power supply board (near the top) and set them aside. Grasp the board firmly on each side. Carefully work the board loose until released.
- 8 Remove the two or three screws from the display Module. Remove the display from the telephone. To install the display, go to [Step 11](#).

Installing the display board

- 9 Place the J1 connector of the display board over the P2 pins of the telephone (see [Figure 75 "Display cable routing" \(page 329\)](#) on [Figure 75 "Display cable routing" \(page 329\)](#)). Press down slowly until J1 slides onto the P2 pins and is firmly seated.

Note: If the center screw is included, do not perform step 10.

- 10 Insert the self-tapping Phillips-head screw supplied with the display into the mounting hole (near the top). Tighten firmly with a #1 Phillips screwdriver.

Installing the display

- 11 Place the display face-down near the top of the telephone and align the two mounting holes of the display with the mounting holes in the telephone.
- 12 Insert two self-tapping Phillips-head screws from the faceplate into the mounting holes; tighten them firmly with a #1 Phillips screwdriver.
- 13 Install the power supply board (see [Procedure 71 "Installing and removing the M2616/M2216ACDPower Supply Board on NTZK sets" \(page 320\)](#)). This step is not necessary on M2616 unless there are other hardware options.
- 14 Fold the ribbon cable near the connector to align it with the J2 pins on the display board, ensuring that the notch on the ribbon cable is facing toward the display board. Carefully work the ribbon cable connector onto the J2 pins until firmly seated. Route the cable flat beside the power supply board, gathering excess cable under the display. Be careful not to press the cable beneath the alignment posts or studs of the base. See [Figure 75 "Display cable routing" \(page 329\)](#) on [Figure 75 "Display cable routing" \(page 329\)](#).

Note: Do not allow R5 on the power supply board to become bent during this procedure.

- 15 Replace the base. If the telephone is equipped with an MPDA or MCA, reconnect the data cable to the base telephone jack and replace the footstand (ensuring that the MPDA or MCA

cable does not get pinched between the base and the footstand). Make sure the footstand is firmly seated in the base.

Note: Place the label supplied with the display on the outside of the bottom cover of the telephone. This allows proper identification and tracking of the option level of the set.

- 16 Tighten all screws, reconnect all cords, and place the telephone in the normal operating position.

Figure 75
Display cable routing

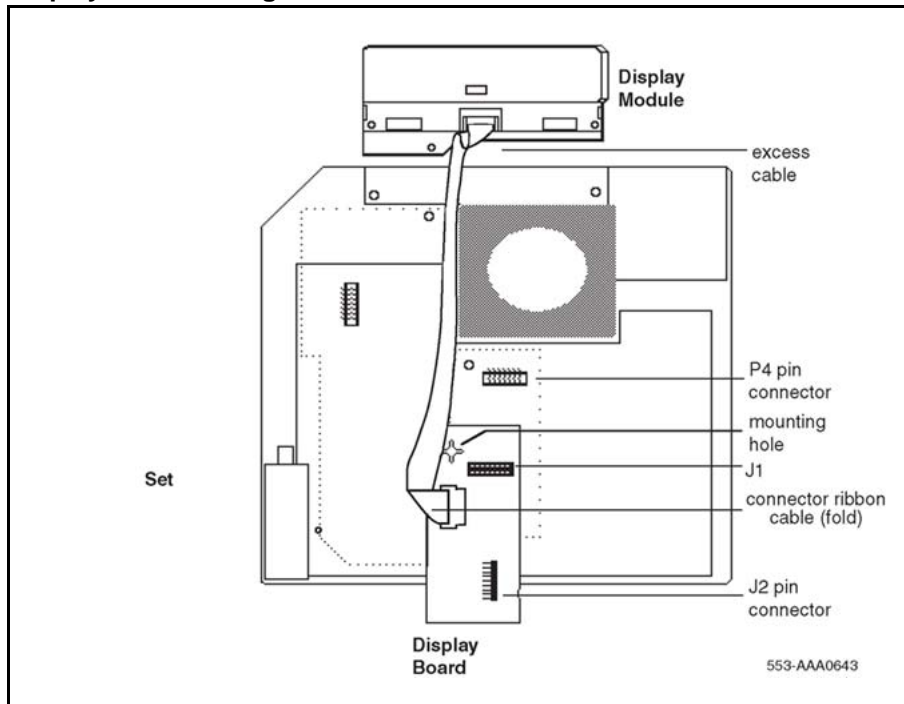

- 17 Perform the self-test (see [Procedure 62 “Meridian Modular Telephones self-test”](#) (page 288)) and acceptance test procedures. See LD 31 in the *Software Input Output Administration (NN43001-611)* ().

--End--

Procedure 74
Installing and removing the M2616 Display
on NT2K sets



CAUTION
CAUTION WITH ESDS DEVICES

Before handling internal components of telephones, discharge static electricity from hands and tools by touching any grounded metal surface or conductor.

Step	Action
1	Remove the handset and place the telephone upside down on top of a level, solid work surface covered with soft material or paper to prevent damage to movable keys and the telephone face.
2	Disconnect all cords from the telephone.
3	Remove the two screws from the footstand assembly and unsnap the footstand assembly by pressing inward at the back of the footstand where it meets the base and pulling upward.
4	If the telephone is equipped with an MPDA or MCA, unplug the data cable from the base telephone jack. Remove the five screws securing the base to the telephone. Remove the base and set it aside.
5	If the telephone is not equipped with a display, go to Step 9 . If the telephone is equipped with a display, go to Step 6 .

Removing the display board

- 6 The display board is located at the left center of the telephone. Disconnect the display ribbon cable from the display board. Remove the small mounting screw from the board. Grasp the board firmly on each end and pull upward to remove it. To replace it, go to [Step 9](#).

Removing the display

- 7 The power supply board is located on the left side of the telephone. Remove the two small screws from the power supply board (near the top) and set them aside. Grasp the board firmly on each side. Carefully work the board loose until released.
- 8 Remove the two or three screws from the display Module. Remove the display from the telephone. To install the display, go to [Step 11](#).

Installing the display board

- 9 Place the J1 connector of the display board over the P4 pins of the telephone (see [Figure 76 "Connecting the cable to the display board" \(page 331\)](#)). Press down slowly until J1 slides onto the P4 pins and is firmly seated.

Figure 76
Connecting the cable to the display board

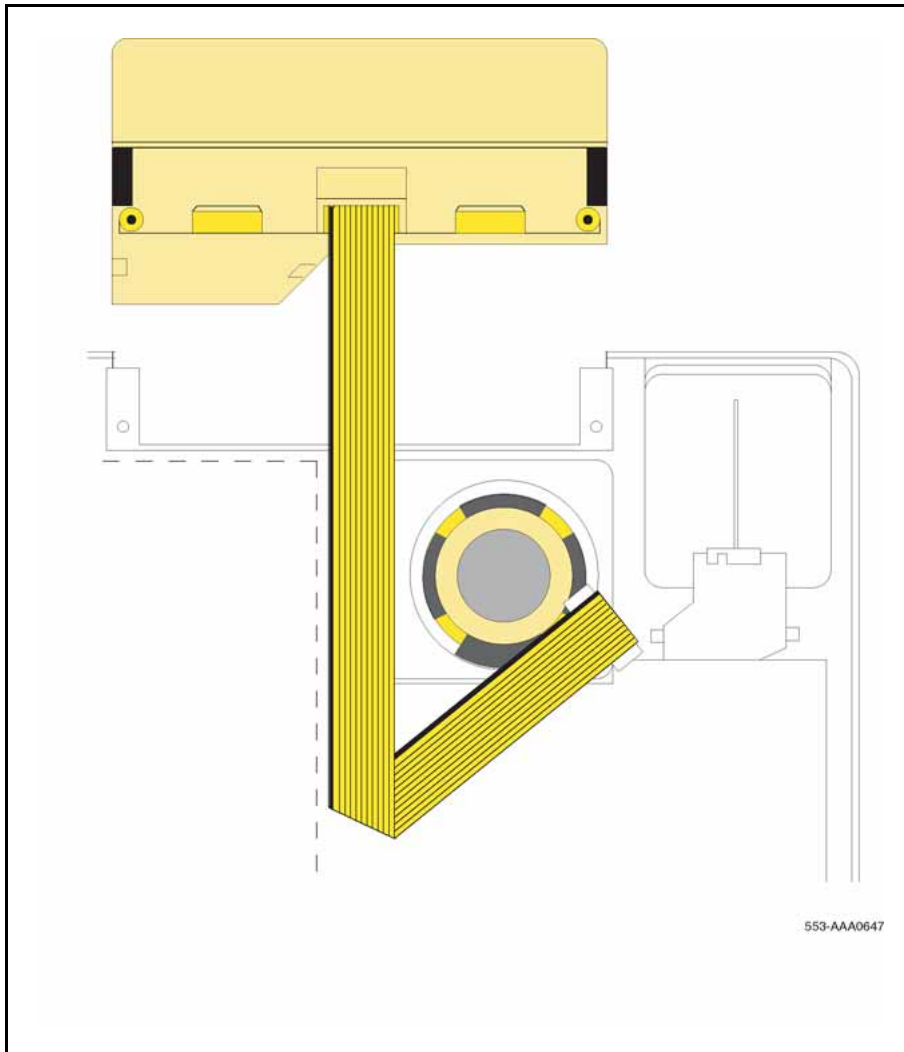

- 10** Insert the self-tapping Phillips-head screw supplied with the display into the mounting hole (near the top). Tighten firmly with a #1 Phillips screwdriver.

Installing the display

- 11** Place the display face-down near the top of the telephone and align the two mounting holes of the display with the mounting holes in the telephone.
- 12** Insert two self-tapping Phillips-head screws from the faceplate into the mounting holes; tighten them firmly with a #1 Phillips screwdriver.
- 13** Install the power supply board (see [Procedure 71 “Installing and removing the M2616/M2216ACD Power Supply Board on NTZK sets”](#) (page 320)). This step is not necessary on the M2616 unless there are other hardware options.

- 14 Fold the ribbon cable near the connector to align it with the J2 pins on the display board, ensuring that the notch on the ribbon cable is facing toward the display board. Carefully work the ribbon cable connector onto the J2 pins until firmly seated. Route the cable flat beside the power supply board, gathering excess cable under the display. Be careful not to press the cable beneath the alignment posts or studs of the base. See [Figure 76 "Connecting the cable to the display board"](#) (page 331).

Note: Do not allow R5 on the power supply board to become bent during this procedure.

- 15 Replace the base. If the telephone is equipped with an MPDA or MCA, reconnect the data cable to the base telephone jack and replace the footstand (ensuring that the MPDA or MCA cable does not get pinched between the base and the footstand). Make sure the footstand is firmly seated in the base.

Note: Place the label supplied with the display on the outside of the bottom cover of the telephone. This allows proper identification and tracking of the option level of the set.

- 16 Tighten all screws, reconnect all cords, and place the telephone in the normal operating position.
- 17 Perform the self-test (see) and acceptance test procedures. See LD 31 in the *Software Input Output Administration (NN43001-611)* () .

--End--

Follow this procedure to add an NT2K28xx display to M2008 and M2616 telephones.

	<p>CAUTION CAUTION WITH ESDS DEVICES</p> <p>Before handling internal components of telephones, discharge static electricity from hands and tools by touching any grounded metal surface or conductor.</p>
-------------------------------------------------------------------------------------	------------------------------------------------------------------------------------------------------------------------------------------------------------------------------------------------------------------------------

Procedure 75
Installing NT2K28AA displays on
NTZK or NT2K sets

Step	Action
<i>Opening the Telephone</i>	
1	Disconnect and remove all cords (including the handset) from the telephone.
2	Place the telephone, upside-down, on a padded, level surface.

- 3 Using a #1 Phillips screwdriver, remove the two screws from the footstand.
- 4 Carefully remove the footstand from the base. Press inward at the back of the footstand where it meets the base and pull upward.
- 5 If the telephone has a Meridian Communications Adapter, unplug its cable from the base telephone jack.
- 6 Loosen all screws on the base of the telephone.
- 7 Remove the base from the telephone.

Removing the Fillerplate

- 8 Loosen the screws that hold the fillerplate.
- 9 Remove the fillerplate, being careful not to touch the foam in the speaker housing.

Attaching the Display Module

- 10 Position the Display Module as shown in [Figure 77 "Positioning the display module" \(page 334\)](#) on [Figure 77 "Positioning the display module" \(page 334\)](#).
- 11 Lower the Display Module into place.

Figure 77
Positioning the display module

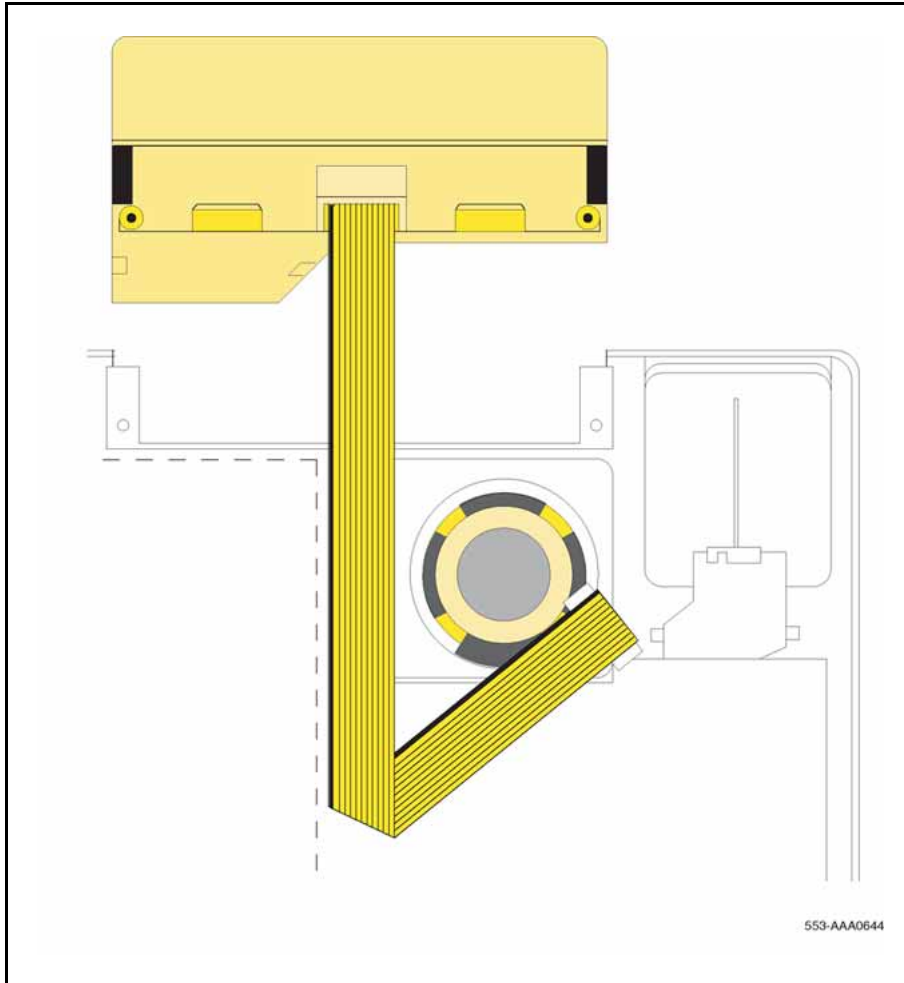

- 12 Insert the fillerplate screws in the Display Module screw holes
- 13 Tighten the fillerplate screws.

Note: Place the label supplied with the display on the outside of the bottom cover of the telephone. This allows proper identification and tracking of the option level of the set.

Connecting the Display Module Ribbon Cable

- 14 If installed, remove and discard the NT2K0013 daughterboard.
- 15 **NTZK models:** Make sure that the ribbon cable is folded as shown in [Figure 78 "Connecting the Display Module Ribbon Cable, NTZK model"](#) (page 335).

Figure 78
Connecting the Display Module Ribbon Cable, NTZK model

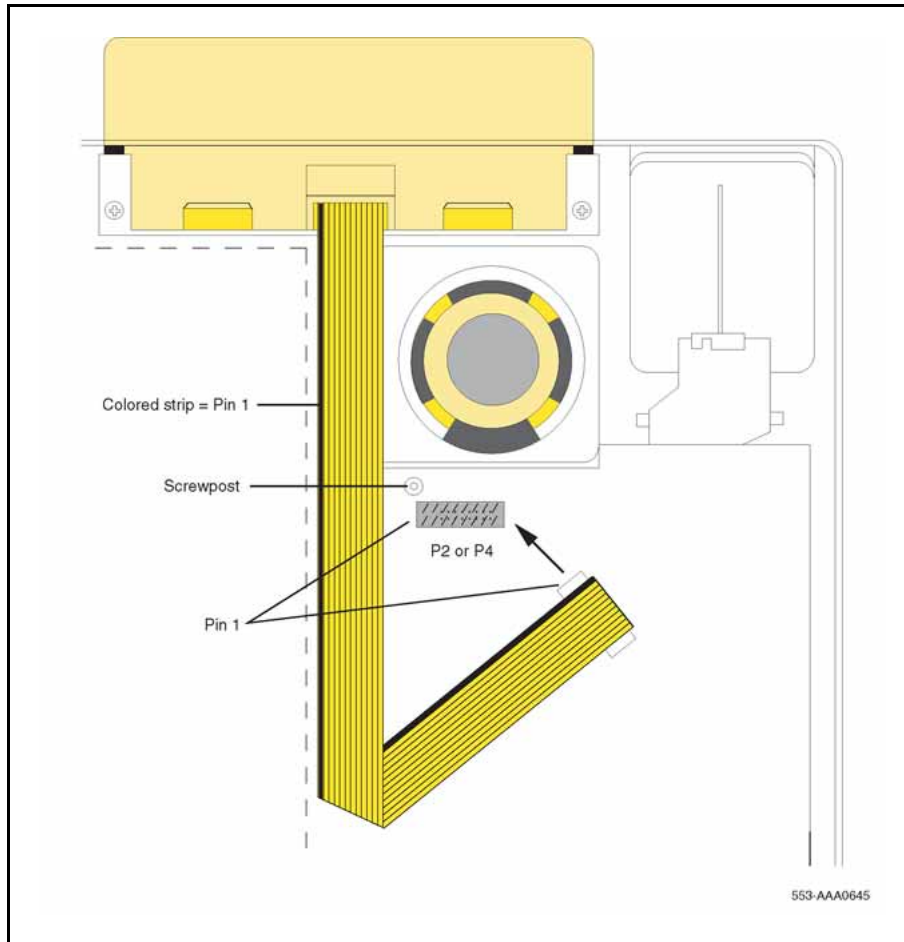

16 **NT2K models:** Make sure that the ribbon cable is folded as shown in [Figure 79 "Connecting the Display Module Ribbon Cable, NT2K model"](#) (page 336) on [Figure 79 "Connecting the Display Module Ribbon Cable, NT2K model"](#) (page 336).

Figure 79
Connecting the Display Module Ribbon Cable, NT2K model

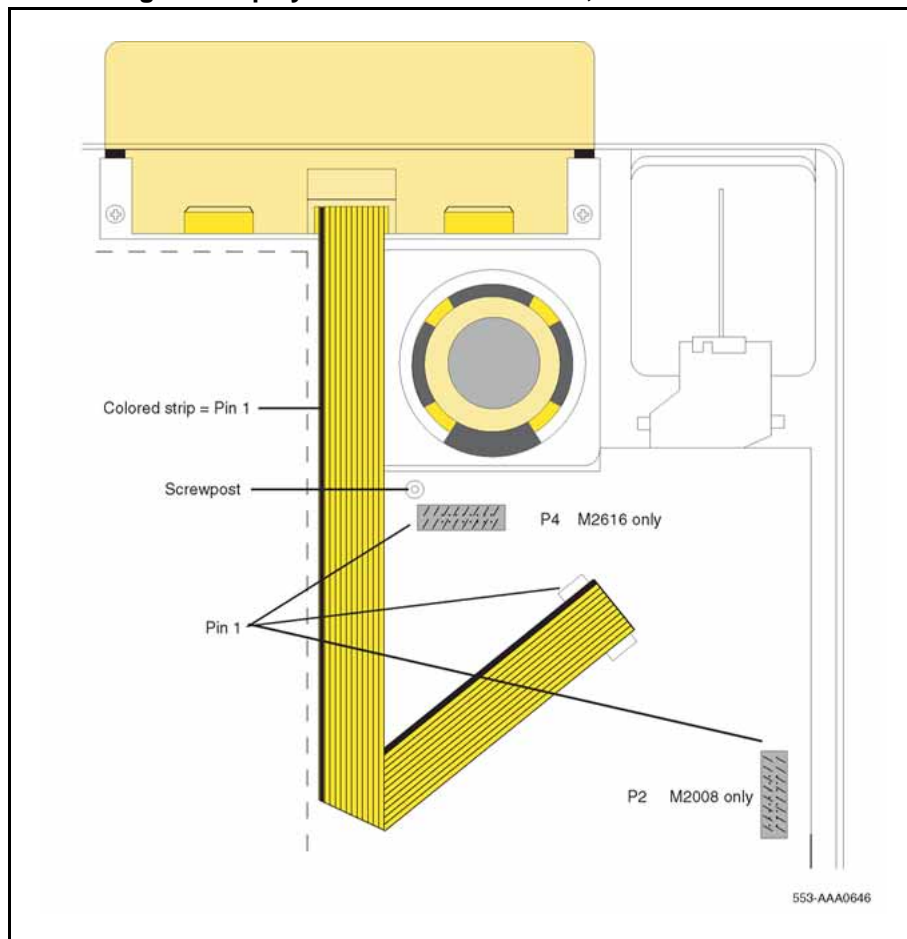

- 17 Make sure the red line on the ribbon cable lines up with the white dot beside the connector pins (P2 on an NTZK M2008, J3 on an NT2K M2008, and P4 on an M2616) on the motherboard.
- 18 Slide the ribbon cable connector onto the connector pins (P2 on an NTZK M2008, J3 on an NT2K M2008, and P4 on an M2616) on the mother board.

	<p>CAUTION This connection is polarity sensitive.</p>
-------------------------------------------------------------------------------------	------------------------------------------------------------------

- 19 Ensure that the pins line up with the connector correctly and carefully work the connector on until it is firmly seated.

Reattaching the Base

- 20 Make sure the ribbon cable is lying flat and not caught over or under any alignment posts or studs on the telephone base. (For

the M2616, allow it to cover the screw post and do not replace the screw on re-assembly.)

- 21 Replace the base.
- 22 Insert all screws (except the center screw on the M2616) and tighten them.

Reattaching the Footstand

- 23 If the telephone has a Meridian Programmable Data Adapter (MPDA) or Meridian Communications Adapter (MCA), plug its cable into the jack on the telephone base.
- 24 Replace the footstand, positioning it firmly on the base.
- 25 Insert and tighten all screws.

Note: Place the label supplied with the display on the outside of the bottom cover of the telephone. This allows proper identification and tracking of the option level of the set.

Reconnecting the Telephone

- 26 Reconnect all cords.
- 27 Turn the telephone right-side-up and place it in a normal operating position.
- 28 Reconnect the handset.

--End--

External Alerter Board

Use [Procedure 76 "Installing and removing the External Alerter Board" \(page 337\)](#) to add an External Alerter Board to the M2006, M2008, M2216ACD, or M2616 telephone. See [Figure 80 "External Alerter connecting block configuration" \(page 340\)](#) for information on hooking up the third-party External Alerter device.

Procedure 76
Installing and removing the
External Alerter Board



CAUTION
CAUTION WITH ESDS DEVICES

Before handling internal components of telephones, discharge static electricity from hands and tools by touching any grounded metal surface or conductor.

Step	Action
1	Remove the handset and place the telephone upside down on a level, solid work surface covered with soft material or paper to prevent damage to movable keys and the telephone face.
2	Disconnect all cords from the telephone.
3	Remove the two screws from the footstand assembly and unsnap the footstand assembly by pressing inward at the back of the footstand where it meets the base and pulling upward.
4	If the telephone is equipped with an MPDA or MCA, unplug the data cable from the base telephone jack.
5	Remove the four screws securing the base of the telephone to the top cover. Remove the base and set aside.
6	If the telephone is not equipped with an External Alerter Board, go to Step 8 . If replacing an existing External Alerter Board, go to Step 7 .

Removing the External Alerter Board

- 7 The External Alerter Board is located at the right center of the telephone. Remove the screws from the board. Grasp the board firmly on each end and pull upward to remove.

Installing the External Alerter Board

- 8 Place the H1 connector of the External Alerter Board over the P3 pins of the telephone (see [Figure 70 "M2006/M2008 telephone and option boards" \(page 319\)](#) on [Figure 70 "M2006/M2008 telephone and option boards" \(page 319\)](#) for M2006/M2008; see [Figure 71 "M2616/M2216ACD telephone and option boards" \(page 320\)](#) on [Figure 71 "M2616/M2216ACD telephone and option boards" \(page 320\)](#) for M2616/M2216ACD). Align the mounting hole over the mounting post. Carefully work H1 onto the P3 pins until firmly seated. Place the self-tapping Phillips-head screw supplied with the External Alerter Board into the mounting hole and tighten it with a #1 Phillips screwdriver.
- 9 To signal the External Alerter when the telephone's handset or speaker is active, place the jumpers (AO288529) connecting the two right-most pins on the alerter board.
- To signal the External Alerter when the telephone is ringing or buzzing, place the jumpers connecting the two left-most pins on the External Alerter Board.
- 10 If the telephone is not yet equipped with the power supply board, install it (see [Procedure 70 "Installing and removing the M2006/M2008Power Supply Board on NTZK sets" \(page 317\)](#) for M2006/M2008; see [Procedure 71 "Installing and removing the](#)

M2616/M2216ACDPower Supply Board on NTZK sets” (page 320) for M2616/M2016S/M2216ACD).

Note: Do not allow R5 on the power supply board to become bent during this procedure.

- 11 Replace the base. If the telephone is equipped with an MPDA or MCA, reconnect the data cable to the base telephone jack and replace the footstand (ensuring that the MPDA or MCA cable does not get pinched between the base and the footstand). Make sure the footstand is firmly seated in the base.
- 12 Tighten all screws, reconnect the line cord, and place the telephone in the normal operating position.

Note: Place the label supplied with the External Alerter on the outside of the bottom cover of the telephone. This allows proper identification and tracking of the option level of the set.

- 13 For the connecting block configuration, see [Figure 80 "External Alerter connecting block configuration"](#) (page 340).
- 14 Perform the self-test (see [Procedure 62 "Meridian Modular Telephones self-test"](#) (page 288)) and acceptance test procedures. See LD 31 in the *Software Input Output Administration (NN43001-611)* ().

Figure 80
External Alerter connecting block configuration

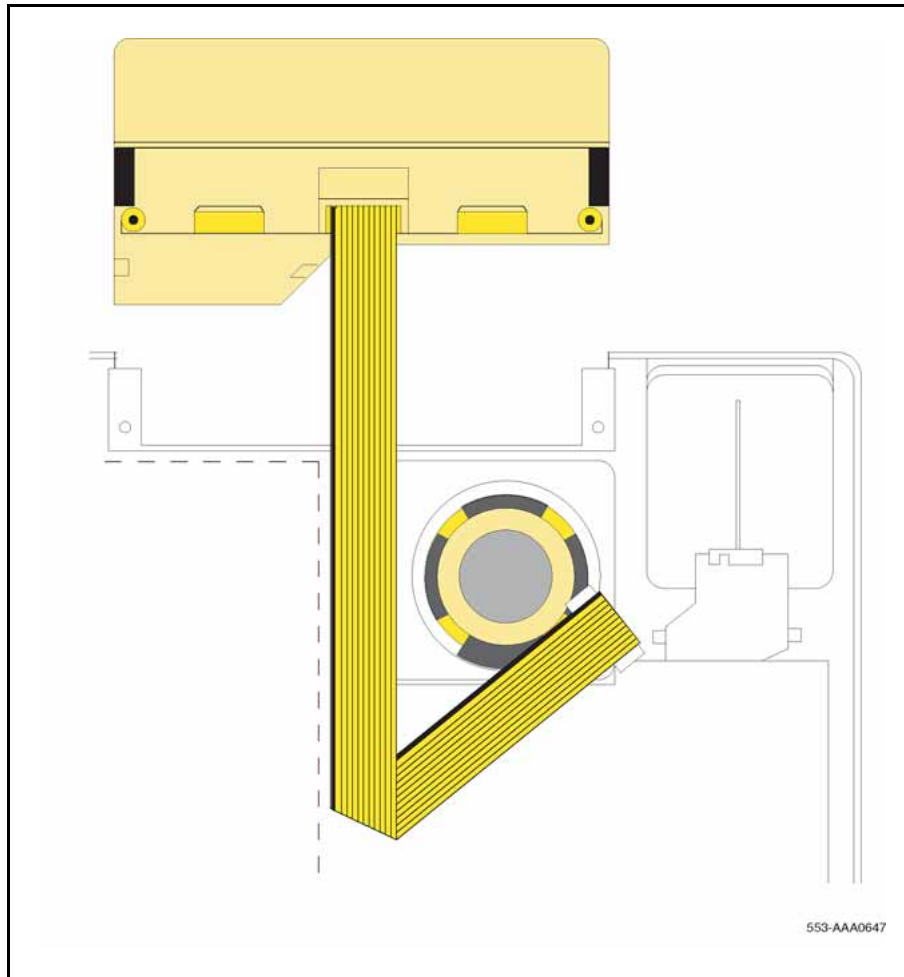

--End--

Key Expansion Modules

Follow the steps in [Procedure 77 "Installing and removing Key Expansion Module\(s\) on the M2616 and M2216ACD telephones"](#) (page 341) to add one (single) or two (double) Key Expansion Modules to the M2616 or M2216ACD telephones.

Note 1: Have the associated footstand on hand before installing the Key Expansion Modules.

Note 2: Adding a Key Expansion Module to a telephone requires a power supply board along with an additional power source (see [Procedure 70 "Installing and removing the M2006/M2008 Power Supply Board on NTZK sets"](#) (page 317) on Procedure 70 "Installing and

removing the M2006/M2008 Power Supply Board on NTZK sets” (page 317) for the M2006/M2008; see Procedure 71 “Installing and removing the M2616/M2216ACD Power Supply Board on NTZK sets” (page 320) for the M2616/M2216ACD).

Procedure 77
Installing and removing Key Expansion Module(s)
on the M2616 and M2216ACD telephones

Step	Action
1	Remove the handset and place the telephone upside down on top of a level, solid work surface covered with soft material or paper to prevent damage to movable keys and the telephone face.
2	Disconnect all cords from the telephone.
3	Remove the two screws from the footstand assembly and unsnap the footstand assembly from the telephone by pressing inward at the back of the footstand where it meets the base and pulling upward.
	<p>Note: If the M2616/M2216ACD is equipped with a Meridian Programmable Data Adapter (MPDA) or Meridian Communications Adapter (MCA), it must be removed and installed into the Key Expansion Module footstand. Use Procedure 68 “Installing and removing the Meridian Communications Adapter or the Meridian Programmable Data Adapter” (page 314) on Procedure 68 “Installing and removing the Meridian Communications Adapter or the Meridian Programmable Data Adapter” (page 314).</p>
4	If the telephone is not equipped with a Key Expansion Module(s), go to Step 7 . If replacing the Key Expansion Module(s), go to Step 5 .

Removing the Key Expansion Module(s)

- 5 Remove the screws from the footstand assembly (where it meets the Key Expansion Module), and unsnap the footstand assembly from the Key Expansion Module and telephone by pressing inward at the back of the footstand where it meets the base and pulling upward.
- 6 Remove the interface cable from the telephone by pressing down on the locking tab. If equipped, remove the interface cable from the first Key Expansion Module (closest to the telephone).

Installing the Key Expansion Module(s)

- 7 If the telephone is not yet equipped with the power supply board, install the Power Board (see [Procedure 71 “Installing and removing the M2616/M2216ACD Power Supply Board on NTZK sets”](#) (page 320) on [Procedure 71 “Installing and removing the](#)

M2616/M2216ACDPower Supply Board on NTZK sets" (page 320)).

- 8 Align the bottom of the Key Expansion Module(s) to the bottom of the telephone (see [Figure 81 "Key Expansion Module connections \(bottom view\)" \(page 343\)](#) on [Figure 81 "Key Expansion Module connections \(bottom view\)" \(page 343\)](#)).
- 9 Snap the ribbon cable connector into the bottom interface jack on the Key Expansion Module.

Note: Use the cable supplied with the module. This is a special cable required for EMI compliance.

Snap the other end of the ribbon cable into the interface jack in the telephone (left side). Gather the excess cable in the base of the Key Expansion Module.

- 10 To add a second Key Expansion Module, snap a second ribbon cable connector into the bottom interface jack on the second Key Expansion Module. Snap the other end of the ribbon cable into the top interface jack on the first Key Expansion Module (see [Figure 81 "Key Expansion Module connections \(bottom view\)" \(page 343\)](#)). Gather the excess cable in the base of the second Key Expansion Module.
- 11 If the telephone is equipped with an MPDA or MCA, reconnect the data cable to the base telephone jack. Make sure the MPDA or MCA cable (and interface cable) do not get pinched between the base and footstand.
- 12 Secure the footstand to the Key Expansion Module(s) and telephone by placing the tabs of the footstand into the slots provided on the base of the Key Expansion Module and telephone and pressing down. Make sure the footstand is firmly seated on the base.

Note: Use the cable supplied with the module. This is a special cable required for EMI compliance. Newer versions of the Key Expansion Module use a longer modified cable than was used on earlier versions.

Ensure that the ribbon cable(s) are not pinched between the footstand and mounting posts.

- 13 Insert the three (four if there are two modules) self-tapping, Phillips-head screws supplied with the Key Expansion Module

into the mounting holes in the bottom of the footstand. Tighten firmly with a #1 Phillips screwdriver.

Note: Place the label supplied with the Key Expansion Module(s) on the outside of the bottom cover or footstand of the telephone. This allows proper identification and tracking of the option level of the set.

- 14 Perform the self-test (see [Procedure 62 “Meridian Modular Telephones self-test” \(page 288\)](#)) and acceptance test procedures. See LD 31 in the *Software Input Output Administration (NN43001-611)* () .

Figure 81
Key Expansion Module connections (bottom view)

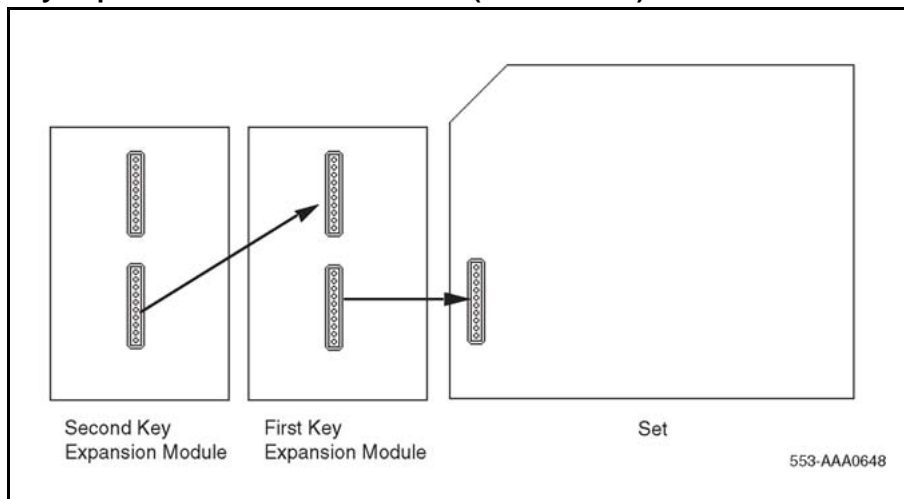

--End--

Asynchronous Data Option

The Meridian Modular Telephones can be equipped with an Asynchronous Data Option (ADO) to enable a data call to be made using keyboard dialing from an attached terminal or personal computer. Voice and data communications can be conducted simultaneously without causing any mutual interference.

Functional description

The ADO is mounted in the telephone and works in conjunction with the Digital Interface Chip to provide asynchronous communication up to 19.2 kbps from an ASCII data terminal or a personal computer to the private Integrated Services Network. The ADO appears as Data Communications Equipment (DCE) in the terminal and connects to the Data Terminal Equipment (DTE) through an RS-232-C connector mounted on the ADO printed circuit board.

The Asynchronous Data Option supports the following:

- Hayes dialing
- Automatic data rate detection at all rates up to 19.2 kbps
- ASCII keyboard dialing (originating data calls to local and remote hosts or DTE by using the terminal keyboard)
- Call origination to local and remote hosts
- Call termination
- Ring Again Capability
- Auto Dial
- Speed Call
- Automatic or Manual answering of incoming data calls
- Manual Modem pooling
- Remote loopback
- Break detection and generation

ADO operating parameters

Table 92 "ADO operating parameters" (page 344) shows the operating parameters for the ADO.

Table 92
ADO operating parameters

Data type	ASCII
Synchronization	Asynchronous, Start-Stop
Number of bits	8 bits
Parity	none (unchecked)
Data rate	300, 1200, 2400, 4800, 9600, 19200 bits per second (autobaud)
Stop bits	2 bits for 110 bits per second; 1 bit for all other speeds
Transmission	Full duplex

The ADO supports asynchronous ASCII operation. A data byte is received from the terminal or PC, a control byte is added, and the two bytes are transferred to the associated line card. In the other direction, two data bytes are received from the line card, the control byte is deleted, and the data byte is delivered to the terminal in a bit serial format, at the terminal's bit rate.

ADO external power supply

The ADO requires an external power supply in addition to the power from the line. See [Table 93 "I/O requirements for ADO external power supply" \(page 345\)](#) on [Table 93 "I/O requirements for ADO external power supply" \(page 345\)](#). A 110 V AC 60 Hz, 100 V AC 50/60 Hz, or a 220 V AC 50 Hz multi-output power supply unit provides nominal voltages of +5 V, +12 V, and -12 V DC. The power supply connects to the back of the telephone through a 5-pin Molex power connector.

If the AC power supply fails, data calls cannot be processed. All external power supplies are equipped with short circuit and thermal shutdown protection.

[Table 93 "I/O requirements for ADO external power supply" \(page 345\)](#) lists the input and output requirements for the ADO external power supply.

Table 93
I/O requirements for ADO external power supply

North American version	
NPS50220-03L5	Multi-output external power supply (A0336823), UL listed and CSA approved
Input:	57–63 Hz 115–132 V AC
Output:	+5 V DC, 1.0 A (pin 3 for supply, pin 2 for return) +12 V DC, 200 mA (pin 6 for supply, pin 1 for return) –12 V DC, 200 mA (pin 4 for supply, pin 1 for return)
Japanese version	
NPS50220-03L8	Multi-output external power supply (A0336891), Japan Standard ("T" Mark)
Input:	47–63 Hz 85–115 V AC
Output:	+5 V DC, 1.0 A (pin 3 for supply, pin 2 for return) +12 V DC, 200 mA (pin 6 for supply, pin 1 for return) –12 V DC, 200 mA (pin 4 for supply, pin 1 for return)
European version	
NPS50220-03L5	Multi-output external power supply (A0336166), conforming to NPS50561 general requirements and UL1012
Input:	57–63 Hz 200–240 V AC
Output:	+5 V DC, 1.0 A (pin 3 for supply, pin 2 for return)

Table 93
I/O requirements for ADO external power supply (cont'd.)

+12 V DC, 200 mA (pin 6 for supply, pin 1 for return) -12 V DC, 200 mA (pin 4 for supply, pin 1 for return)

Figure 82 "Block diagram of ADO and M2317 telephone" (page 346) shows a block diagram of the ADO and an M2317 telephone.

Figure 82
Block diagram of ADO and M2317 telephone

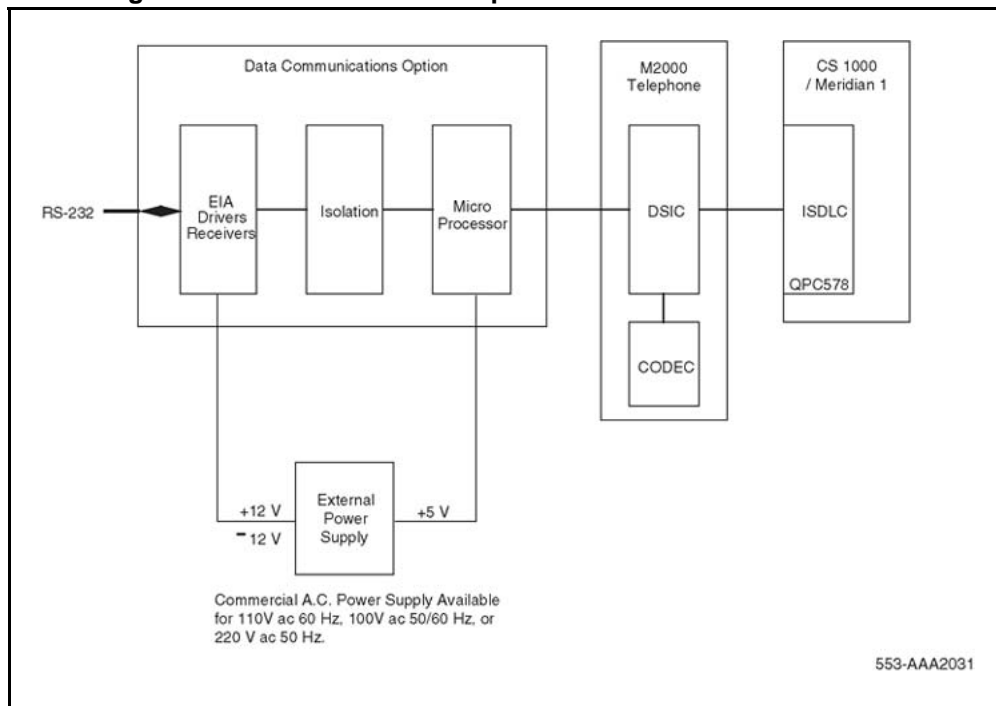

See the *Asynchronous Data User Guide* () and the *M2317 Quick Reference Card* () , for more information on ADO operation.

M2317 Data Option

If an existing digital telephone was not originally equipped with the Data Option, or if the existing Data Option has become defective, that option can be added or replaced. [Procedure 78 "Installing the M2317 data option"](#) (page 347) explains how to install the Data Option for the M2317 telephone.



CAUTION
CAUTION WITH ESDS DEVICES

CMOS devices inside the telephone can be damaged by electrostatic discharge. Before opening any M2317 telephone, discharge your hands and tools by touching any grounded metal surface or conductor.

Procedure 78
Installing the M2317 data option

Step	Action
1	Remove the handset, and place the telephone upside down on a level workplace (a desktop, for example).
2	Disconnect all cords from the telephone.
3	Loosen and remove five screws in the base of the telephone, lifting the base upward.
4	If the telephone is not equipped with the ADO, proceed with step 5. If the telephone is equipped with a defective ADO, carefully disconnect the ribbon cable connector from the header connector in the digital printed circuit board. Loosen and remove the two self-tapping screws that fasten the ADO to the telephone base and remove the defective ADO. Proceed with step 6. See Figure 83 "M2317 data terminal and Data Option power supply connection" (page 349) on Figure 83 "M2317 data terminal and Data Option power supply connection" (page 349) .
5	Remove the breakout section in the rear of the telephone base by tapping it with the handle of a small screwdriver.
6	Place the black plastic connector shroud over the RS-232-C interface connector. Note: It is not possible to install the shroud after the board has been inserted in the telephone base.
7	Tip the circuit board up and insert it, connector end first, under the tabs in the base. Position it over the molded locating pins; then lower the board completely into position in the telephone base. Use the three slotted, self-tapping screws supplied with the board and install them through the mounting holes. Tighten the screws.
8	Plug the ribbon cable connector into the header connector, located on the existing circuit board of the telephone (mounted on the faceplate assembly). Only one such connector is located on the telephone's circuit board. Make sure the connector is snug.

- 9 Reassemble the telephone by placing the base section on the faceplate section. Reinstall the five screws.
- 10 Tighten the screws, reconnect all cords, and place the telephone in its former position.
- 11 Refer to [Procedure 79 "Installing the M2317 data terminal"](#) (page 348) to connect the power supply and data terminal to the ADO.

--End--

Procedure 79
Installing the M2317 data terminal

Step	Action
1	Connect the RS-232-C interface connector from the data terminal to the matching header connector in the back of the telephone. See Figure 83 "M2317 data terminal and Data Option power supply connection" (page 349) on Figure 83 "M2317 data terminal and Data Option power supply connection" (page 349).
2	Insert the two captive screws in the connector body into the threaded holes in the header connector. Secure them tightly to prevent accidental disconnection during data terminal operation.
3	Insert the keyed power supply plug securely into the 5-pin power connector located to the right of the RS-232-C connector.
4	Plug the wall transformer into the nearest AC outlet. The data terminal is now operational. Note 1: If an ADM3, ADM5, or ADM11 terminal is used in conjunction with the RS-232-C connector in the Asynchronous Data Option, pin 22 in the RS-232-C cable must be disconnected. These ADM terminals will go into test mode if this pin is not disconnected. Note 2: A special 9-pin connector is required to connect the Apple Macintosh to the RS-232-C connector in the Meridian Modular Telephone Asynchronous Data Option. The connections are shown in Table 94 "Connections for the Apple Macintosh to the M2317 Asynchronous Data Option (ADO)" (page 349) on Table 94 "Connections for the Apple Macintosh to the M2317 Asynchronous Data Option (ADO)" (page 349).

--End--

Figure 83
M2317 data terminal and Data Option power supply connection

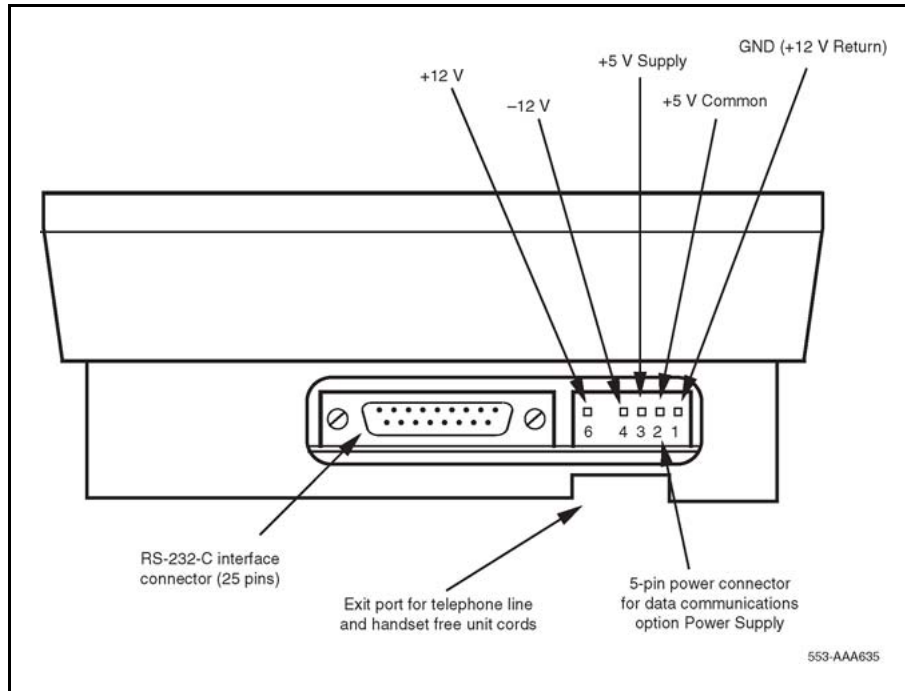

Table 94
Connections for the Apple Macintosh to the M2317 Asynchronous Data Option (ADO)

9-pin connector (from terminal)		25-pin (RS-232-C) connector (at ADO port)
Pin 3	to	Pin 7
Pin 5	to	Pin 2
Pin 9	to	Pin 3
Note: Strap pins 4 and 5 and pins 6, 8, and 20 together.		

Table 95
RS-232-C signals and associated pin numbers for M2317 telephones

Circuit designation			Pin number	Signal source		
EIA	Common	CCITT		DTE	DCE	Name
AA		101	1		X	Frame ground
BA	TXD	103	2	X		Transmit data
BB	RXD	104	3		X	Receive data
CA	RTS	105	4	X		Request to send
CB	CTS	106	5		X	Clear to send
CC	DSR	107	6		X	Data set ready

Table 95**RS-232-C signals and associated pin numbers for M2317 telephones (cont'd.)**

AB	GND	102	7	X	Signal ground
CD	DTR	108.2	20	X	Data terminal ready
CE	RI	125	22	X	Ring indicator

Meridian Communications Unit

The Meridian Communications Unit (MCU) provides a stand-alone version of the Meridian Communications Adapter (MCA).

Functional description

The Meridian Communications Unit (MCU) enables data to be transmitted and received using PSDS, over either the public network or a private network.

The MCU, which replaced the QMT21C, is designed for domestic and international use, with transmission speeds up to 19.2 kbps asynch and 64 kbps synch, integrated display, and self diagnostics.

The MCU supports autodialing, ring again, and speed calling, as well as autobauding and automatic parity detection. The MCU can be used for the following:

- Video conferencing
- LAN bridging
- Bulk data/PC file transfer
- Dial back-up
- Host connectivity

The MCU fully complies with RS-232C and can be configured as DCE or DTE to connect to a terminal, printer, or fax machine.

Unlike the MCA, the MCU provides a dedicated call key and call progress tones. The MCU also enables smart modem pooling.

The MCU supports the DM-DM, T-Link, V.25 bis, and PSDS interfaces as well as the RS-232C, CCITT V.35, CCITT V.24, and RS570/RS3449 (with different cables) interfaces. It complies with V.28 for European approval.

Wall mounting

The M2006, M2008, M2616, and M2016S telephones are equipped with a reversible footstand that allows for wall mounting. The wall-mount clip should be purchased and inserted in the handset well to hold the

handset securely in place on wall-mounted telephones. Meridian Modular Telephones can be hung on the wall with an installed display or Key Expansion Module.

Note: The footstand cannot be reversed when the Meridian Programmable Data Adapter or Meridian Communications Adapter is equipped, so telephones with data cannot be wall mounted. Additionally, some wall plates are too deep to allow for wall mounting on top of the plate. In these cases, mount the telephone on the wall next to the plate.

An additional clip is provided for wall mounting the telephone. This clip is attached to the switchhook rest to prevent the handset from slipping when mounted on the wall.

Procedure 80
Wall mounting instructions for Meridian Modular Telephones

Step	Action
1	Remove the handset and place the telephone upside down on top of a level, solid work surface covered with soft material or paper to prevent damage to movable keys and the telephone face.
2	Disconnect all cords from the telephone.
3	Remove the two screws from the footstand assembly and unsnap the footstand assembly by pressing inward at the back of footstand where it meets the base, and pulling upward.
4	Rotate the footstand 180° and snap the footstand back into place on the telephone bottom cover. Make sure the footstand is firmly seated on the base of the telephone.
5	Tighten all screws and replace all cords.
6	Insert the wall-mounting clip in the switchhook rest.
7	Mount the telephone on the wall using the wall-mount holes provided on the bottom of the footstand.

--End--

Troubleshooting

Use [Table 96 "Troubleshooting Meridian Modular Telephones"](#) (page 352) to check problems encountered when installing Meridian Modular Telephones and their options.

Table 96
Troubleshooting Meridian Modular Telephones

Symptom	Solution
Telephone does not work.	1 Unplug the line cord from the telephone and plug it back in.
	2 If the telephone uses external power, make sure the transformer or closet power supply is properly connected and that the power supply board is properly installed.
	If the telephone does not use external power, make sure that jumpers are placed connecting the bottom two sets of pins on the P1 connector on the main circuit board.
All LCDs flash and telephone does not function.	1 Press the Release (RIs) key.
	2 Unplug the line cord from the telephone and plug it back in.
	3 Ensure that all cords are properly routed through channels in the footstand.
Telephone wobbles.	1 Ensure that all cords are properly routed through channels in the footstand.
	2 Check that the footstand is firmly seated on the telephone.
	3 Ensure that all feet are firmly seated in the footstand.
Display does not work.	1 Unplug the line cord from the telephone and plug it in again.
	2 Ensure that the transformer is plugged in or the closet power is connected (M2008 only).
	3 Ensure that the power supply board is installed properly (M2008 only).
Display does not work. (cont.)	4 Check that the display ribbon cable is properly connected to the display board and has not been pinched.
	5 Ensure that the display board is installed correctly and held securely with a mounting screw.
	6 M2006, M2008, M2616 – ensure that ADD Class of Service is configured in LD 11. See the <i>Software Input Output Administration (NN43001-611) ()</i> .
<p>Note 1: If the pseudorandom pattern 511 data is idle, the telephone keypad dialing is inoperative. Use the release key to clear this condition.</p> <p>Note 2: If using an RS-232 cable to connect the MCA to an ADM3/5 terminal, be sure that pin 22 is disconnected.</p> <p>Note 3: Change the baud rate before changing the mode from synchronous to asynchronous.</p> <p>Note 4: Some terminals may drop DTR with the break. If this happens, RELEASE is not displayed.</p>	

Table 96
Troubleshooting Meridian Modular Telephones (cont'd.)

Symptom	Solution
There is no response when you type <CR> or AT at the terminal.	1 Press the P key and dial 28 to make sure you are in terminal mode.
	2 Make sure the PC or terminal's has power and is online.
	3 If the equipment connected to the MCA is not configured as Data Terminal Equipment, it is necessary to connect using a null modem cable.
	4 Make sure the MCA is receiving external power. Check to see that the power cables are connected properly and the external power supply is running.
	5 If there is a display on the telephone, press the P key and dial 63 to get into EIA Monitor mode. Be sure the MCA is receiving signals from the terminal by watching the display while entering carriage returns on the keyboard. If the indicator flashes, the connection is correct. If not, check the cable to make sure it is the standard RS-232 and is properly connected.
	6 Press the P key and dial 62 to ensure that the MCA is in the asynchronous mode. Press the P key and dial 20 to change to the asynchronous mode.
	7 Press the P key and dial * to ensure that the MCA is in the idle mode.
The prompt CALL CONNECTED. SESSION STARTS is followed by RELEASE.	Check the configuration parameters of the far end data device. If they do not match those of the MCA, the call will be dropped. Change the parameters of your MCA to match.
Garbled prompts are sent to your terminal when you type <CR>.	Enter a period (.) followed by <CR> to perform an autoparity.
<p>Note 1: If the pseudorandom pattern 511 data is idle, the telephone keypad dialing is inoperative. Use the release key to clear this condition.</p> <p>Note 2: If using an RS-232 cable to connect the MCA to an ADM3/5 terminal, be sure that pin 22 is disconnected.</p> <p>Note 3: Change the baud rate before changing the mode from synchronous to asynchronous.</p> <p>Note 4: Some terminals may drop DTR with the break. If this happens, RELEASE is not displayed.</p>	

Table 96
Troubleshooting Meridian Modular Telephones (cont'd.)

Symptom	Solution
You are connected to a host computer, but get no response when you try to log on.	First, release the call. Turn on Remote Loopback and make the call again. Type some characters at the terminal. If the characters echo back and appear on the terminal, the problem is with the far end data device. If the characters do not appear on the terminal, the problem is with the MCA. Contact the telephone system administrator.
You try to make a data call from the initial prompt (or Main menu) in keyboard dialing. You see the prompt CALLING.	First, hold down the break key(s) for two seconds, enter <CR>, and try again to make the data call. If the problem persists, the MCA is probably disabled. Contact the telephone system administrator.
MCA does not operate at all.	<ol style="list-style-type: none"> 1 Check the LED in the back of the telephone to see if it is flashing. If the LED is steadily lit, the MCA needs to be configured in the system, or it may be bad. If the LED is not lit, the MCA requires external power. 2 Make sure the cable from the terminal or PC is connected to the MCA. 3 Check the data parameters for the display. 4 Be sure the transformer is plugged in, or the closet power is connected. 5 Be sure the cable between the MCA and the telephone is connected and has not been pinched. 6 Be sure the power card is installed correctly. Verify that the jumper settings are correct for either RS-232 or V.35 (whichever you are using).
Key Expansion Module does not work.	<ol style="list-style-type: none"> 1 Unplug and plug in the line cord. 2 Ensure that the transformer is plugged in or that the closet power supply is connected. 3 Ensure that the power supply board is installed properly. 4 Make sure that the ribbon cable connecting the telephone and the Key Expansion Module is routed properly and is not pinched.
<p>Note 1: If the pseudorandom pattern 511 data is idle, the telephone keypad dialing is inoperative. Use the release key to clear this condition.</p> <p>Note 2: If using an RS-232 cable to connect the MCA to an ADM3/5 terminal, be sure that pin 22 is disconnected.</p> <p>Note 3: Change the baud rate before changing the mode from synchronous to asynchronous.</p> <p>Note 4: Some terminals may drop DTR with the break. If this happens, RELEASE is not displayed.</p>	

Table 96
Troubleshooting Meridian Modular Telephones (cont'd.)

Symptom	Solution
External Alerter does not work.	1 Ensure that the External Alerter Board is installed properly.
	2 Check that connections between the alerting device and the telephone connecting block are correct.
	3 Make sure that the jumpers are placed on the pins on the External Alerter Board as described in Procedure 76 "Installing and removing the External Alerter Board" (page 337) .
	4 Ensure that the transformer is plugged in or the closet power is connected.
	5 Ensure that the power supply board is installed properly.
<p>Note 1: If the pseudorandom pattern 511 data is idle, the telephone keypad dialing is inoperative. Use the release key to clear this condition.</p> <p>Note 2: If using an RS-232 cable to connect the MCA to an ADM3/5 terminal, be sure that pin 22 is disconnected.</p> <p>Note 3: Change the baud rate before changing the mode from synchronous to asynchronous.</p> <p>Note 4: Some terminals may drop DTR with the break. If this happens, RELEASE is not displayed.</p>	

Figure 84
Flowchart for troubleshooting MCA

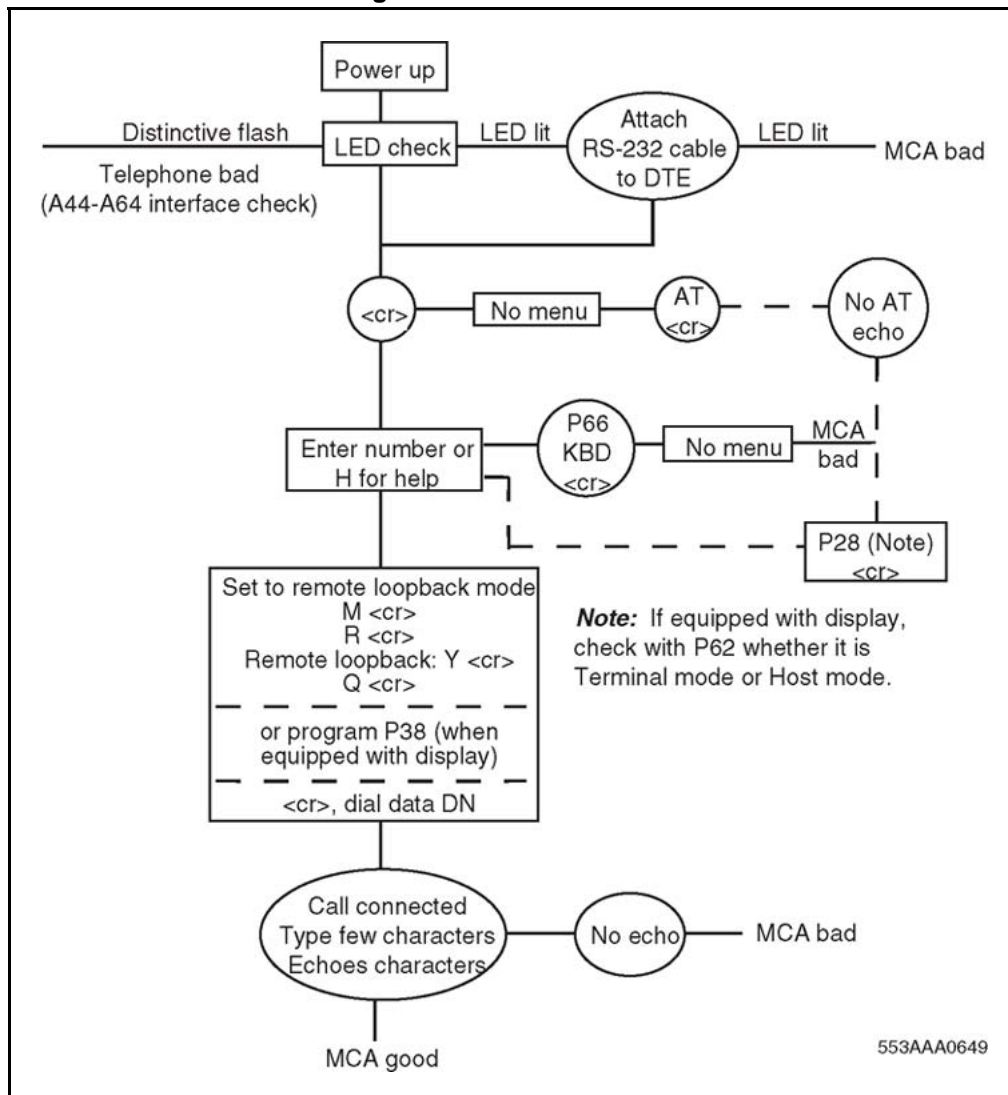

553AAA0649

Appendix

M2317 telephone

Contents

This section contains information on the following topics:

- “Introduction” (page 357)
- “Feature description” (page 358)
 - “Firmware features” (page 358)
 - “Software features” (page 359)
- “Physical description” (page 360)
 - “Housing” (page 360)
 - “Keys” (page 360)
 - “Software requirements” (page 367)
- “Specifications” (page 367)
 - “Safety considerations” (page 368)
 - “Environmental considerations” (page 368)
 - “Dimensions and weight” (page 368)
 - “Line engineering” (page 369)
 - “Power requirements” (page 369)
 - “Data communication” (page 372)
 - “Data characteristics” (page 372)

Note: This section is for reference only. The M2317 telephone is manufacture discontinued and no longer available.

Introduction

The M2317 Telephone can provide simultaneous voice and data communications. It connects to the system using digital transmission. The M2317 Telephone is intended for professionals and managers, and secretaries in group answer positions. It interfaces with the system

through the Digital Line Card (DLC). It is connected to the switching equipment through a two-wire loop carrying two independent 64 kb/s Time Compressed Multiplex (TCM) channels with associated signaling channels. One of the two TCM channels is dedicated to voice, and the other to data traffic.

The M2317 telephone has the following features:

- A built-in, two-line (40 characters per line) Liquid Crystal Display (LCD) screen and integrated Handsfree.
- A telephone line cord and the handset cord equipped with standard modular connectors at each end, that enables quick replacement when required.

The M2317 Telephone is equipped with a microphone and speaker to permit Handsfree operation. [Figure 85 "M2317 Telephone" \(page 358\)](#) shows the M2317 Telephone.

Figure 85
M2317 Telephone

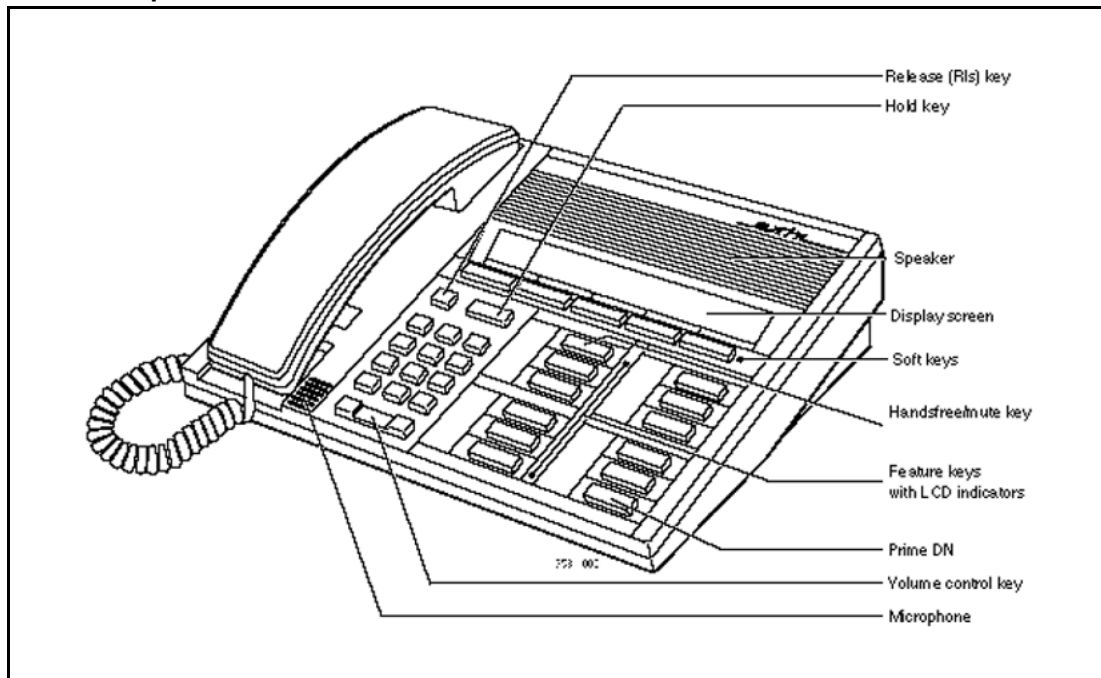

Feature description

Firmware features

Firmware is chip-dependent and cannot be changed or altered on site. As a general rule, all firmware is on ROM microchips. Firmware is built into the M2317 telephone and the CS 1000 and Meridian 1 systems.

Firmware functions

The following functions are performed by firmware in the M2317 Telephone:

- Predial
- Last Number Redial
- Saved Number
- Redial Saved Number
- Timer
- Time and Date
- Call Processing

Software features

Downloading

All information related to the programmable keys must be downloaded into the M2317 RAM memory through the DLC.

Soft keys are automatically defined for the telephone based on COS, data base or package restrictions. Soft keys work only in conjunction with the LCD display screen.

Table 97
M2317 data features

Data features	M2317	DTE Keyboard
Ring Again	X	X
Speed Call	X	X
System Speed Call	X	X
Display		X
Call Forward	X	
Call Transfer (Note)		X
Autodial	X	X
Last Number Redial	X	
Save Number	X	
Redial Saved Number	X	
Manual modem pooling using keyboard dialing requires only call transfer to be defined.		
The Data DN must always be assigned to feature key 10.		

Physical description

The M2317 Telephone is fully modular. The telephone line cord and the handset cord are both equipped with TELADAPT connectors at each end, which permits quick replacement when required.

Housing

The housing of the M2317 digital telephone consists of a molded plastic base and faceplate. The display module and the main circuit board are fastened to the underside of the faceplate. The Asynchronous Data Option (ADO) circuit board, if equipped, is mounted inside the base.

Keys

The M2317 Telephone is equipped with 32 keys that are arranged as follows:

Fixed keys

These are 16 keys to which a fixed function is assigned. They consist of:

- 12 dial pad keys
- 1 Release key
- 1 Hold key
- 1 Volume control key (with 2 toggle positions)
- 1 Handsfree/Mute key (with associated LCD indicator)

Feature keys

There are 11 programmable line/feature keys on the telephone faceplate. Each has an associated LCD indicator. Lines and features are assigned to these keys by service changes in the system software. A maximum of ten voice Directory Numbers and specific features such as, Auto Answerback, Call Waiting, Dial Intercom, and Display can be assigned.

Soft keys

The M2317 telephone has five LCD-labeled soft keys located immediately beneath the display screen. Each softkey has a seven-character-wide label on the display screen immediately above the key. The labels change as the available features change. For example, a softkey could access one feature in the idle state and a different feature in the active state.

The fifth softkey "**more...**" is used to scroll to a second layer feature menu when there are more softkey-assigned features available for the active telephone state. Pressing the "**more...**" key brings up the labels for the remaining functions. Softkey label positions on the display screen are fixed by the M2317 telephone firmware and cannot be changed by the user.

Alphanumeric display screen

The M2317 telephone is equipped with a two-line (40 characters per line capacity) LCD screen. The 155 x 15 mm (6 x 0.6 in) LCD screen has a capacity of 80 characters (two lines of 40 characters each). The first line displays date and time during the idle state, incoming call identification, feature icons, user prompts, and messages. The second line displays the labels for the soft keys (seven characters per key).

Handsfree key

When Handsfree is on, a user can talk to another party without lifting the handset. Handsfree can be activated by pressing the Handsfree/Mute key, or by pressing a DN key without lifting the handset. The Handsfree/Mute LCD indicator shows the status of the Handsfree. Once Handsfree is activated, it can be deactivated by picking up the handset or by pressing the Release (RLS) key.

Handsfree operates as if an off-hook operation had been performed. For example, when the telephone is idle, pressing the Handsfree/Mute key turns on the Handsfree and selects a DN (depending on line selection as assigned through COS), enabling the user to make a call. When a call comes into an M2317 and the set is ringing, pressing the Handsfree/Mute key turns on the Handsfree and enables the user to answer the incoming (ringing) call (depending on COS-assigned line selection) without picking up the handset.

The M2317 provides independent volume adjustments for Handsfree, handset, and alerting tone volumes (on-hook dialing and buzz). For detailed information on adjusting the volume, refer to the *M2317 Quick Reference Card* ().

LCD indicators

LCD indicators support the following four key/LCD states:

Function	LCD state
idle	off
active	on (steady)
ringing (or "feature pending")	flash (60 Hz)
hold	fast flash (120 Hz)

The following figures show the M2317 key layout and the different telephone states that can be displayed on the M2317 screen.

Figure 86
M2317 telephone, key identification

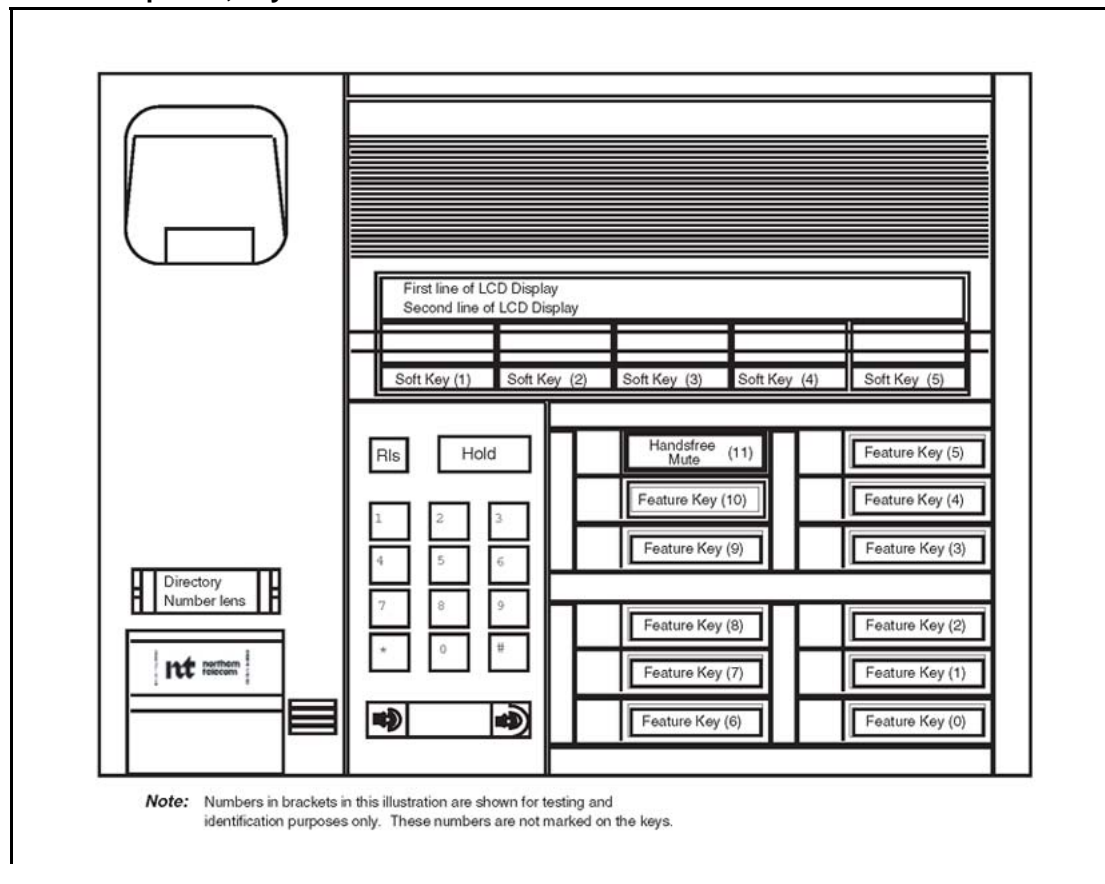





Figure 87
M2317 screen display, available idle state features



Displays Month, Day, Hour, Minutes

MMM DD HH : MM				
SAVED #	LAST #	CANCL 	--->>	more...
HELD #	FORWARD	CHECK 	TIMER	more...
RLSDATA	DATA	SPEED	FRENCH	more...

Note 1: Only one row of softkey labels is displayed at a time. Additional rows are accessed by operating the "more..." softkey. The five softkeys are located beneath the screen display in line with each displayed label.

Note 2: The HELD # softkey label is displayed on the screen only when there is a held conference/transfer call.

Note 3: The CANCL  softkey label is displayed on the screen only when the "Ring Again" feature has been activated.

Note 4: The FORWARD and CHECK  (Check Call Forward) labels are mutually exclusive; the FORWARD key label changes to CHECK  when calls are forwarded.

Note 5: The RLSDATA label is displayed only when there is an active data call.

Note 6: The --->> key is only offered when CPND is used.

553-AAA0731

Figure 88
M2317 screen display, dialing state

Displays Month, Day, Hour, Minutes

3	MMM DD HH : MM			

553-AAA0733

Figure 89
M2317 screen display, ringback state

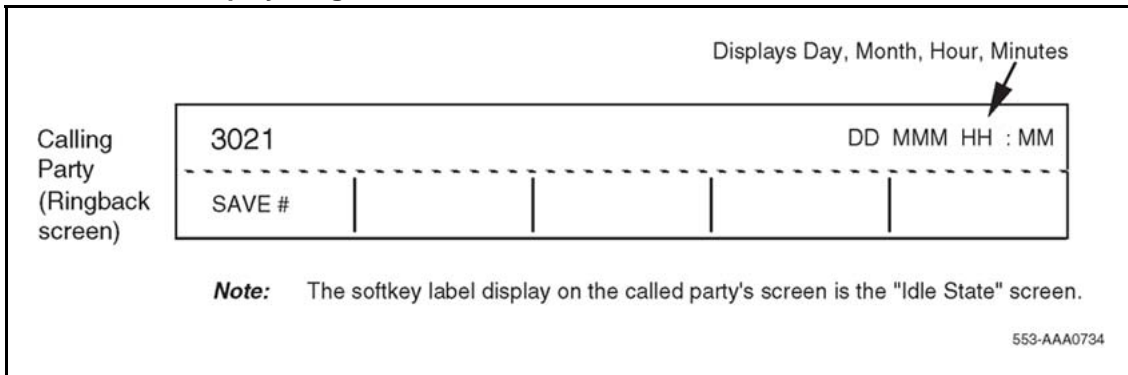
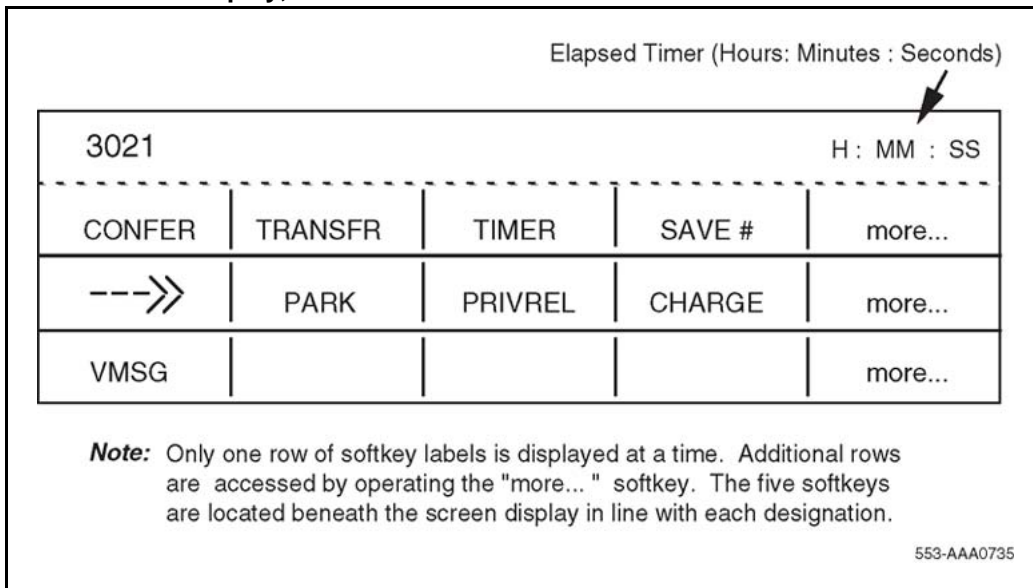

Figure 90
M2317 screen display, available established state features



Not all the features listed in [Table 98 "M2317 states and associated soft keys"](#) (page 365) are provided for each customer. Check only those features that are enabled in accordance with the work order.

The - - ->> symbol display is associated with the Call Party Name Display (CPND) feature. CPND must be enabled before it can be accessed.

Table 98
M2317 states and associated soft keys





Screen state	State	Softkey display
Idle	On-hook, voice or data	Saved#, LAST#, CANCL  --->, more..., HELD#, FORWARD, CHECK  TIMER, more..., RLSDATA, DATA, SPEED
Dialtone	Ready to transmit dialed digits (voice)	Saved#, LAST#, CALL  SPEED#, more..., MESSAGE, PICKUP, ACCOUNT, more...
Intercom dialtone	Ready to transmit dialed digits for an intercom call (voice)	PICKUP
Dialing	Transmitting dialed digits	no soft keys shown
Private Line dialing	Transmitting dialed digits on a private line (voice)	SAVED#, LAST#
Busy	Called party off-hook (voice)	RINGAGN, SAVE#
Reorder	Called party is unavailable (voice)	no soft keys shown
Ringback	Called party is ringing (voice)	SAVE#
ERWT call back	Initial set of ESN routes not available. Set gets Expensive Route Warning Tone (voice).	RINGAGN, SAVE#
Established	Voice connection made	CONFER, TRANSFR, TIMER, SAVE#, more..., --->>, PARK, PRIVREL, CHARGE, more..., MESSAGE, more...
Intercom established	Connection made with an intercom group (voice)	CONFER, TRANSFR, TIMER
Private Line established	Connection made with a private line (voice)	CONFER, TRANSFR, TIMER
Voice Call/Group Call established	Connection made using a voice key or group call key (voice)	no soft keys shown
Conference/Transfer dialtone	Special dialtone (voice)	SAVED#, LAST#, CALL  SPEED, ACCOUNT
Conference/Transfer dialing	After special dialtone is heard, dialing the call (voice)	no soft keys shown

Table 98
M2317 states and associated soft keys (cont'd.)

Screen state	State	Softkey display
Conference/Transfer busy	After special dialtone is received, called party is off-hook (voice)	RINGAGN, SAVE#
Conference/Transfer reorder	After special dialtone is received, called party is unavailable (voice)	no soft keys shown
Transfer ringback	Used xfer feature, and the called party is ringing (voice)	CONNECT, SAVE#
Conference ringback	Used conf feature, and the called party is ringing (voice)	SAVE#
Consultation	The third party (consulting party called by xfer/conf feature) has answered the call (voice)	CONNECT, SWAP
Consultation Hold	The user is talking to the original party and the consulting party is on hold (voice)	CONNECT, SWAP
Established Hold	Call held by other party (voice)	no soft keys shown
User status	Leave telset msg for set's status (voice)	no soft keys shown
Display	The user has operated the feature key "DSP" to display the speed/system speed call numbers (voice or data)	SPEED#, EXIT
Program	The user has operated a feature key that requires user-input such as Auto Dial or Controlled Class of Service (COS)	no soft keys shown
Data call initiation	The user pressed data DN key to make a data call (data)	CALL  , SPEED#, SAVED#, LAST#
Data call dialing	Transmitting dialed digits (data)	no soft keys shown
Data call busy	Called party off-hook (data)	RINGAGN, SAVE#
Data call reorder	Called party is unavailable (data)	no soft keys shown
Data call ringback	Called party is ringing (data)	SAVE#
Data call ERWT call back	Initial set of routes not available. Set gets Expensive Route Warning Tone (ERWT).	RINGAGN, SAVE#
Data call established	Connection made (data)	SAVE#

Asynchronous Data Option

See [“Asynchronous Data Option” \(page 343\)](#) for more information on ADO requirements.

Software requirements

All information related to the programmable keys must be downloaded into the M2317 RAM memory through the DLC or ISDLC. Downloading to the telephone is performed when the system is loaded or when a telephone is enabled.

Soft keys are automatically defined for the telephone based on Class of Service (CLS), database, or package restrictions. Soft keys work only in conjunction with the LCD display screen.

[Table 99 "M2317 data features" \(page 367\)](#) lists the data features supported by the M2317 firmware.

Table 99
M2317 data features

Data features	M2317	DTE Keyboard
Ring Again	X	X
Speed Call	X	X
System Speed Call	X	X
Display		X
Call Forward	X	
Call Transfer (Note 1)		X
Autodial	X	X
Last Number Redial	X	
Save Number	X	
Redial Saved Number	X	
<p>Note 1: Manual modem pooling using keyboard dialing requires only call transfer to be defined.</p> <p>Note 2: The Data DN must always be assigned to feature key 10.</p>		

Specifications

The following specifications govern the safety and performance of the Meridian M2317 Telephone, and outline the environmental conditions under which this performance is achieved.

Safety considerations

Shock and fire hazards

For protection against electrical shock, energy hazards, or fire hazards, the telephone meets the following specifications:

CSA, C22.2 No. 0.7 – M1985

UL 1459, relevant sections

Overvoltage protection

The M2317 telephone meets the specifications detailed by CSA, C22.2 No.7, paragraph 6.9.3.

Environmental considerations

Temperature and humidity

Operating state:

Temperature range 0° to 50° C (32° to 122°F)

0° to 40° C (32° to 104°F) with Data Option

Relative humidity 5% to 95% from 4° to 29°C (39° to 84° F)

noncondensing

5% to 34% from 29.5° to 49°C (85° to 120°F)

noncondensing

Storage:

Temperature range –20° to 70° C (–4° to 158° F)

Relative humidity 5% to 95% from –20° to 29°C (–4° to 84°F)

noncondensing

5% to 15% from 29.5°C to 66°C (85° to 150°F)

Dimensions and weight

The M2317 digital telephone has the following dimensions:

depth	226.5 mm (9 in)
width	272.0 mm (10.1 in)
height (front)	27.5 mm (1.1 in)
height (rear)	73.5 mm (2.9 in)

Excluding the power supply and the NT1F09AC Asynchronous Data Option board, the M2317 weighs approximately 1.4 Kg (3 lb). With the Data Option installed, the telephone, excluding power supply and data cable, weighs approximately 1.56 Kg (3.5 lb).

Line engineering

The M2317 digital telephones operate to their full potential through twisted pair wiring on transmission lines selected by the rules given in “[Digital telephones line engineering](#)” (page 223) &c. The maximum permissible loop length is 1067 m (3500 ft.) of 22 or 24 AWG or 760 m (2500 ft.) of 26 AWG standard twisted wire with no bridge taps or load coils.

The 1067 m (3500 ft.) loop length requires the use of a Digital Line Card (DLC) or an Integrated Services Digital Line Card (ISDLC) NT8D02, or later.

Power requirements

The M2317 digital telephone uses loop power for all circuits requiring +10 V. To satisfy the power requirements for those circuits on a maximum loop, as defined in “[Digital telephones line engineering](#)” (page 223), 60mA of 13.5 V DC must be available at the telephone. The line card must have compatible voltage and source resistance to meet these requirements.

Logic and other circuitry requiring +5 V is powered from an external, regulated +5 V DC supply when the data option is not installed. The external power supply must meet the following specifications:

Input:	95–129 V AC, 60 Hz
Output:	+5 V DC, + or –5%, 300 mA
	10 mV maximum RMS ripple
Cord:	2.5 m (8 ft.) of 20 AWG wire mating to a Switchcraft 722A connector
Case:	Wall-mounted, CSA and UL approved.
	Operational within 0°C (32°F) and 50°C (122°F) temperature limits
Impedance:	Greater than 10 M ³ / ₄ to ground

The external power supply, in all cases where no Asynchronous Data Option is installed, is connected to the mating connector mounted in the rear of the M2317 telephone. It covers the area where the RS-232-C interface connector would be located.

Note: If the Asynchronous Data Option is installed, an external, multi-output data power supply is required. Refer to NPS50220-03L5. See “Asynchronous Data Option” (page 343) for more information on ADO requirements.

The data option power supply connector plugs into the back of the telephone next to the RS-232-C interface connector. Data option installation requires the removal of the telephone power supply connector.

The NPS50220-03L5 power supply meets the following specifications:

- AC input voltage: 105 - 132 V AC
- Input line frequency: 57 - 63 Hz
- Operating temperature: 0° to 50°C (32° to 122°F)
- Operating humidity: 5% to 95% non-condensing
- Storage temperature: -40° to 70°C (-40° to 158°F)

Figure 91
M2317 telephone cross-connections

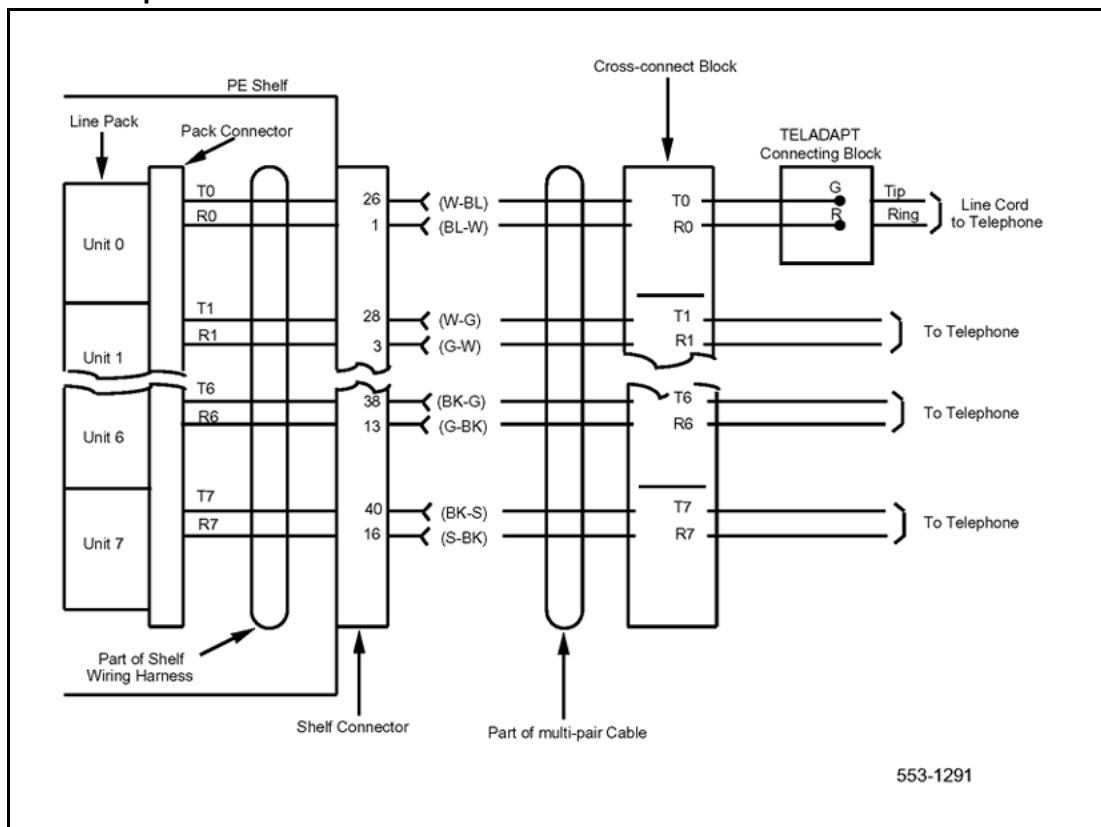

- Output voltages:
 - +5 V DC at 1.0 A
 - 12 V DC at 200 mA
 - +12 V DC at 200 mA
- Case dimensions: 178 x 102 x 76 mm (7 x 4 x 3 in.)

The NPS50220-03L5 is equipped with an internal thermal and short circuit protection.

Whenever the external power supply fails (due to failure of the power utility), the M2317 Telephone assumes Plain Ordinary Telephone Service (POTS) status. At this time the telephone is capable of receiving and originating calls on the prime DN, and of giving the usual alerting tones (ringing). It will not support the Display screen, soft keys, feature keys, Handsfree, or data facilities while in POTS status.

Figure 92
Block diagram of M2317

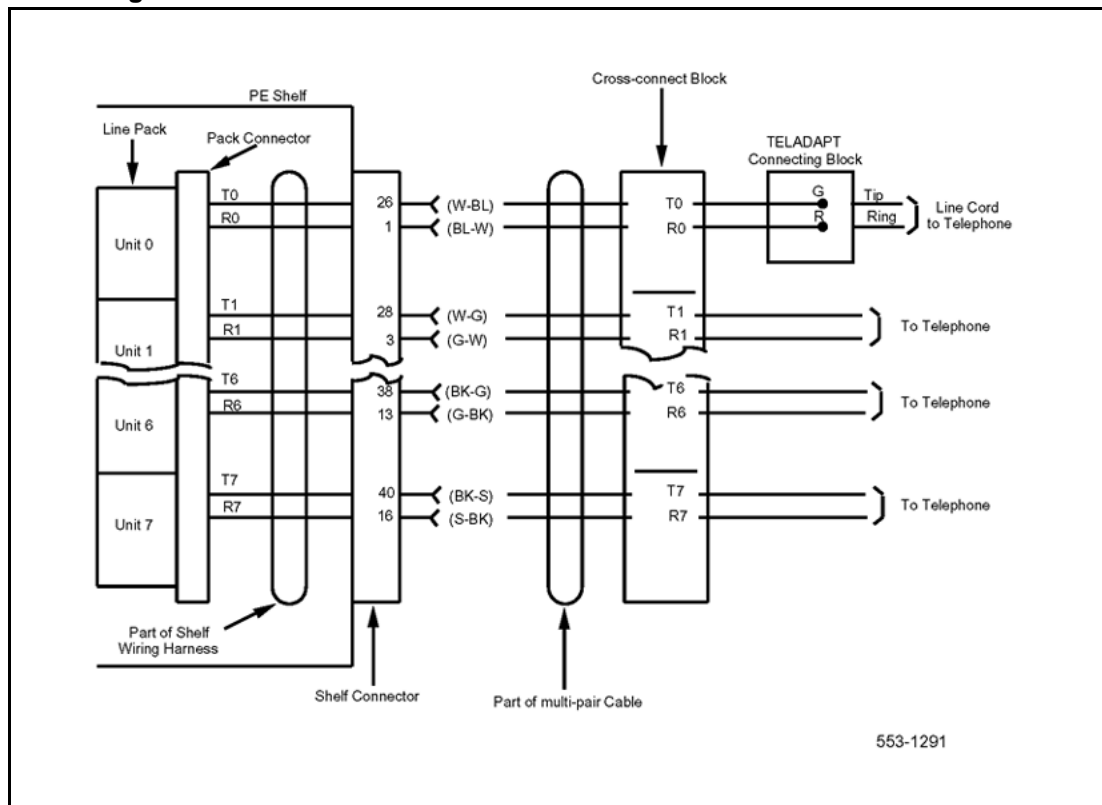

Data communication

The M2317 can be equipped with an Asynchronous Data Option which will permit the use of either the telephone's dial pad or the feature keys to place and terminate data calls in the asynchronous mode. The Data Option also supports keyboard dialing from the data terminal when that terminal operates in the asynchronous mode.

The Asynchronous Data Option is equipped with a dialing feature which enables the user to originate data calls to local and remote Data Terminal Equipment (DTE) directly from a data terminal keyboard or personal computer. The dialing feature, in conjunction with the communications firmware provided with the Data Option, supports most of the HAYES Smartmodem dialing features. Terminal emulation packages can also be used with the dialing feature.

Data characteristics

The M2317 Asynchronous Data Option communicates with Data Terminal Equipment (DTE) having characteristics as follows:

Data type	ASCII
Synchronization	Asynchronous, Start-Stop
Number of Bits	8 bits
Parity	none (unchecked)
Data rate	300, 1200, 2400, 4800, 9600, 19200 bits per second (autobaud)
Stop bits	2 bits for 110 bits per second; 1 bit for all other speeds
Transmission	Full duplex

Appendix

M3110, M3310, and M3820 telephones

Contents

This section contains information on the following topics:

- “Feature description” (page 374)
 - “M3110” (page 374)
 - “M3310” (page 377)
 - “M3820” (page 377)
 - “Meridian digital telephones used with a headset” (page 378)
- “Physical description” (page 379)
 - “Fixed keys (same for all three models)” (page 380)
 - “Additional feature keys” (page 382)
 - “Programmable Feature keys” (page 383)
 - “Software requirements” (page 383)
- “Terminal options” (page 383)
 - “Meridian External Alerter and Recording Interface” (page 384)
 - “Brandline Insert” (page 384)
 - “Key Expansion Module” (page 384)
 - “Meridian Communications Adapter” (page 384)
- “Configuration and installation” (page 385)
 - “Configuration” (page 385)
 - “Installation” (page 388)
 - “Installing hardware options” (page 389)
- “Specifications” (page 393)
 - “Environmental and safety considerations” (page 393)
 - “Line engineering” (page 394)

[“Local alerting tones” \(page 395\)](#)

[“Power requirements” \(page 396\)](#)

Note: This section is for reference only. The M3110, M3310, and M3820 sets are manufacture discontinued and no longer available.

Feature description

The Meridian European Digital telephones series of telephones, which is only available in Europe, consists of the following telephones:

- M3110
- M3310
- M3820

Meridian digital telephones are designed to provide cost-effective integrated voice and data communication. These telephones communicate with the CS 1000 and Meridian 1 systems by using digital transmission over standard twisted-pair wiring. They interface with the system using the Integrated Services Digital Line Card (ISDL) or the eXtended Digital Line Card (XDLC).

Meridian digital telephones are connected to the system through a two-wire loop carrying two independent 64 kbs PCM channels with associated signaling channels. One of the two PCM channels is dedicated to voice while the other is dedicated to data traffic.

The telephone interfaces with the Digital Line Card (XDLC) or ISDL in the Intelligent Peripheral Equipment shelf of the system. The XDLC supports 16 voice and 16 data ports. The ISDL supports eight voice and eight data ports. A TN is assigned to each port in the system software.

M3110

The M3110 Meridian digital telephone supports the following features:

- On-Hook Dialing and Group Listening
- Dedicated release and hold keys

Figure 93
M3110 Meridian digital telephone

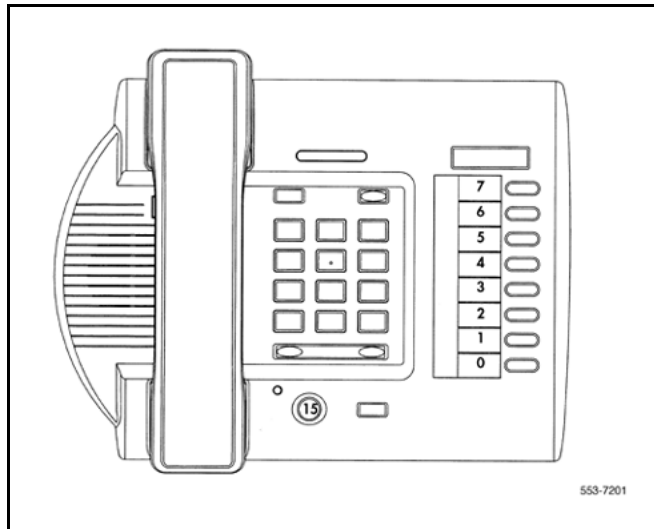

- Message Waiting and Mute Indicators
- 10 Feature System Programmable keys including:
 - 8 system programmable keys
 - Mute key
 - Speaker key
- Volume control for:
 - Handset
 - Ringing Tone
 - Buzz Tone
 - On-Hook Dialing and Group Listening

Figure 94
M3310 Meridian digital telephone

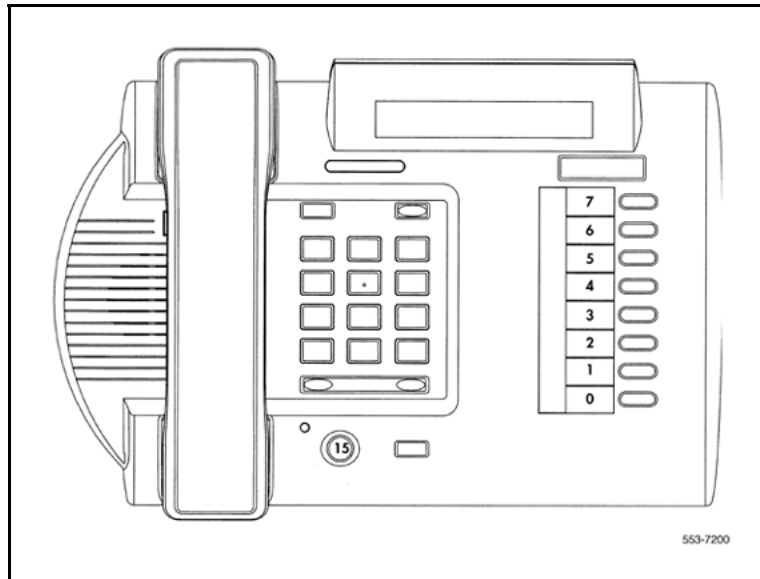
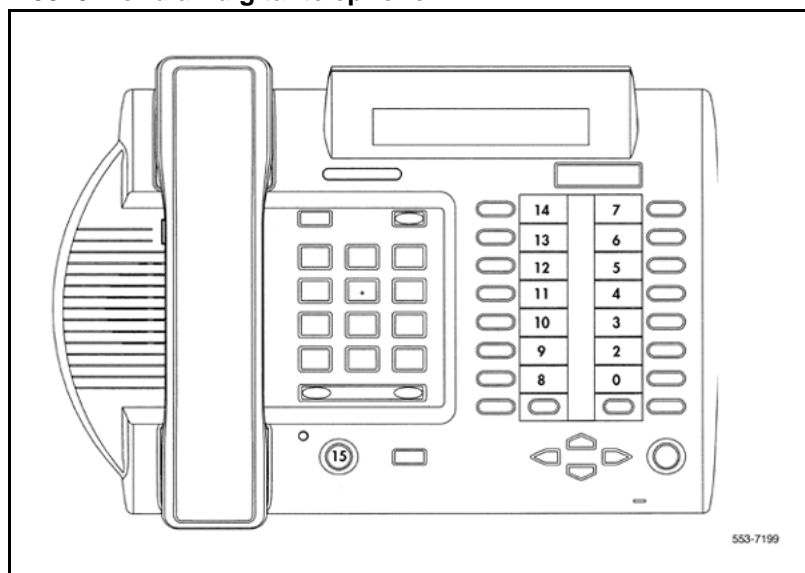

Figure 95
M3820 Meridian digital telephone



- Support for the following terminal options:
 - MCA data option to provide integrated voice and data
 - External Alerter for high ambient noise environments
- Wall-mount ability
- Brand line insert to provide for special company logos

M3310

The M3310 Meridian digital telephone supports the following features:

- Handsfree, On-Hook Dialing and Group Listening
- Dedicated Release and Hold keys
- Message Waiting and Speaker/Mute Indicators
- Headset Socket
- 2 x 24 character display
- 10 Feature keys including:
 - Program key
 - 7 system programmable keys
 - Speaker key
 - Mute key
 - Volume control for:
 - Handset/Headset
 - Ringing Tone
 - Buzz Tone
 - On-Hook Dialing and Group Listening
 - Handsfree
- Support for the following set options:
 - MCA data option to provide integrated voice and data
 - External Alerter for high ambient noise environments
 - Wall-mount ability
- Brand line insert to provide for special company logos

M3820

The M3820 Meridian digital telephone supports the following features:

- Handsfree, On-Hook Dialing and Group Listening
- Dedicated Release and Hold keys
- Message Waiting and Speaker/Mute Indicators
- Headset Socket
- 2 x 24 character display
- 20 Feature keys including:

- Store/program key
- 13 system programmable keys
- Handsfree/speaker key
- Mute key
- Directory key
- Caller's List key
- Edit key
- Delete key
- Volume control for:
 - Handset/Headset
 - Ringing Tone
 - Buzz Tone
 - On-Hook Dialing and Group Listening
 - Handsfree
- Directory/Caller's List with 9 dedicated keys namely:
 - Directory, Callers, Edit, Delete, 4 cursor and Dial
- Support for the following terminal options:
 - MCA data option to provide integrated voice and data
 - External Alerter for high ambient noise environments
 - Wall-mount ability
 - Add-on Key Expansion Modules (2 maximum)
- Brand line insert to provide for special company logos

Meridian digital telephones used with a headset

You can use an electret headset in the headset port of the digital telephones (M3310 and M3820 only). Alternatively, choose an amplified headset that draws power from a battery or AC transformer; power is not provided by the telephone. The amplifier must draw less than 400 micro amps from the telephone jack.

The headset should be designed to work with a telephone jack with these characteristics:

Transmit interface: +5 V through 10K DC bias resistance with maximum current of 500 micro amps. The differential input impedance is 10K ohms. Connects to pins 2 and 5 of the headset jack.

Receive interface: single ended output with output impedance of 180 ohms. Connects to pins 3 and 4 of the headset jack.

Physical description

Meridian digital telephones support many general features as illustrated in [Table 100 "Meridian digital telephone general features" \(page 379\)](#).

Table 100
Meridian digital telephone general features

Feature	M3820	M3310	M3110
Handsfree, On-Hook Dialing, and Group Listening	yes	yes	yes
Dedicated Release and Hold keys	yes	yes	yes
Message Waiting and Speaker/Mute Indicators	yes	yes	yes
Headset Socket	yes	yes	no
2 x 24 character display	yes	yes	no
Feature keys including:	20	10	10
• Store/program key	yes	yes	no
• system programmable keys	13	7	8
• Handsfree/speaker key	yes	yes	yes
• Mute key	yes	yes	yes
• Directory key	yes	no	no
• Caller's List key	yes	no	no
• Edit key	yes	no	no
• Delete key	yes	no	no
Volume control for:			
• Handset/Headset, Ringing Tone, Buzz Tone, On-Hook Dialing and Group Listening	yes	yes	yes
• Handsfree	yes	yes	no
Directory/Caller's List with dedicated keys for Directory, Callers, Edit, Delete, 4 cursor and Dial	yes	no	no
Terminal options:			
• MCA data option to provide integrated voice and data, External Alerter for high ambient noise environments, Wall-mount ability	yes	yes	yes

Note: The location of the buttons used to activate and interact with these features is shown in [Figure 96 "The location and function of buttons on the Meridian digital telephone" \(page 381\)](#).

Table 100
Meridian digital telephone general features (cont'd.)

Feature	M3820	M3310	M3110
• Add-on Key Expansion Modules (2 maximum)	yes	no	no
Brand line insert to provide for special company logos	yes	yes	yes

Note: The location of the buttons used to activate and interact with these features is shown in [Figure 96 "The location and function of buttons on the Meridian digital telephone"](#) (page 381).

Fixed keys (same for all three models)

Hold

By pressing the hold key, you can put an active call on hold. Return to the caller by pressing the extension key beside the flashing LCD indicator.

Release (RIs)

You can terminate an active call by pressing the RIs key or by hanging up the handset. The release key is especially useful for disconnecting handsfree and headset calls.

Volume control

The volume key controls the volume of the handset, the speaker and the ringer. Raise the volume by pressing the right side of the bar. Lower it by pressing the left side.

Mute

When engaged in a call, you can press the mute key. The party(ies) to whom you are speaking cannot hear you. This is especially useful when on a conference call and you are only listening. When you wish to return to the two-way conversation, you must push the mute key again. The mute key applies to handsfree, handset and headset microphones.

Speaker/Handsfree

The speaker key allows you to activate handsfree and group listening features. Handsfree is only available on the M3310 and M3820 models and is enabled by the system administrator. If handsfree is not configured at the switch, the telephone can only be used to listen.

Figure 96
The location and function of buttons on the Meridian digital telephone

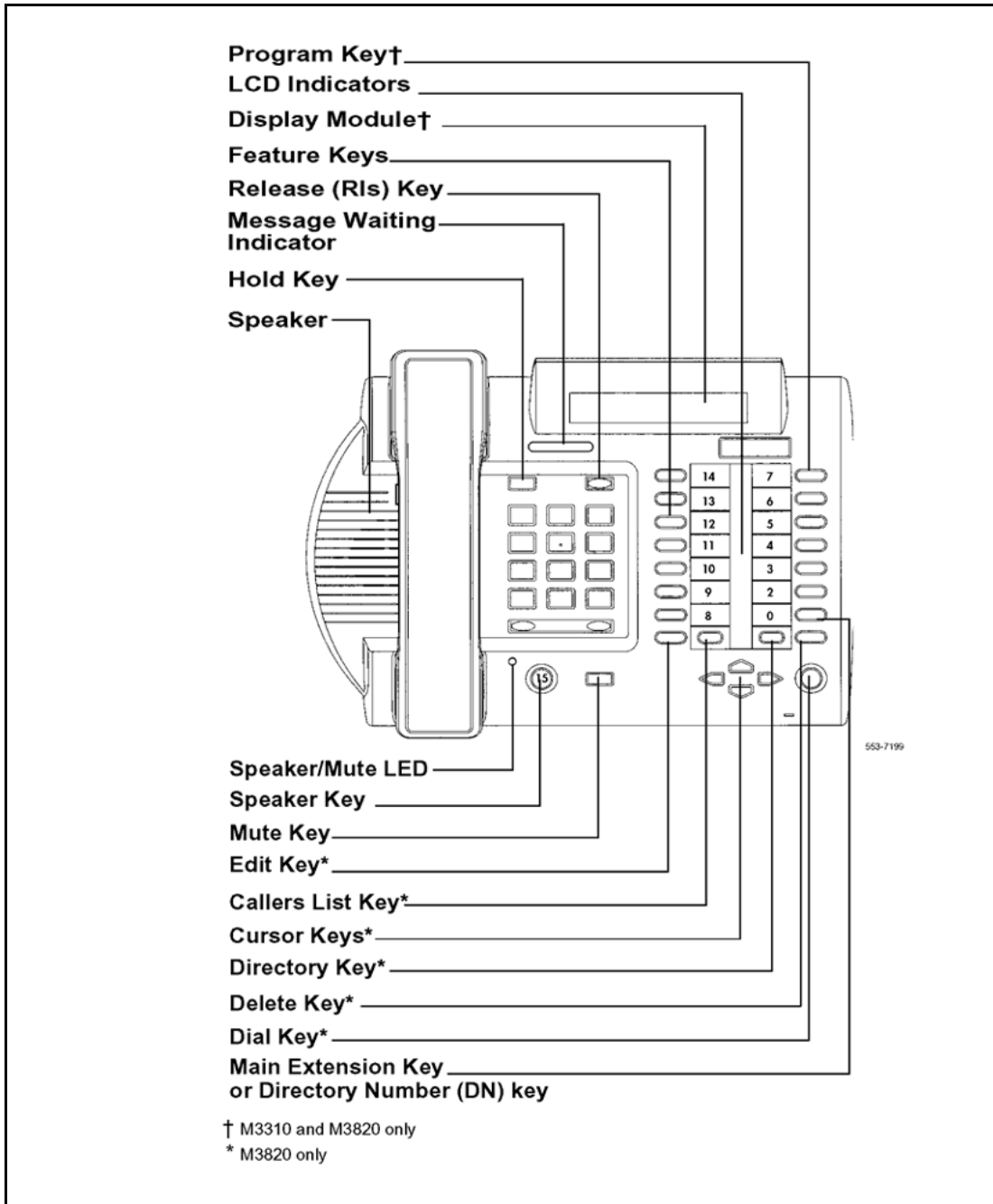

The table below indicates the mode the terminal is in when the speaker is operated under the various switch and set operations.

Table 101
Speaker Key Function

MODEL	Handsfree not selected at the switch	Handsfree selected at the switch - Group listening off	Handsfree selected at the switch - Group listening On
M3820	CPM and primary DN key-Speaker LED is not illuminated	HF and Primary DN key - speaker LED is on when in Handsfree mode	HF, Group listening and Primary DN key - speaker LED is on when in HF or Group Listening mode
M3310	CPM and Primary DN key-Speaker LED is not illuminated	HF and Primary DN key - Speaker LED is on when in HF mode	HF, Group Listening and Primary DN key - Speaker LED is on when in HF or group listening
M3110	CPM and Primary DN key- Speaker LED is not illuminated	N/A	Group listening and Primary DN key - speaker LED is on when in Group listening mode.

Note 1: CPM is Call Process Monitor which enables the user to hear, for example, the dial tone in the speaker. Group listening enables the user to speak through the handset/headset microphone and one or more parties can listen through the speaker, thus hearing both sides of the conversation. In Handsfree mode, the user (or group of users) uses both the handsfree microphone and speaker.

Note 2: Group listening is switched on or off under the program key option *1. (M3820 and M3310 only)

Additional feature keys

Message Waiting lamp key

Each telephone has a red message waiting LED just above the hold and Rls keys that lights to indicate a message is waiting. This LED is the primary message waiting indicator and lets you know that a message is waiting, regardless of whether the telephone has a message waiting key/lamp pair. You must have Message Waiting allowed Class of Service. See LD 11, *Software Input Output Administration (NN43001-611)* () and *Software Input Output Reference - Maintenance (NN43001-711)* () .

If you do assign a message waiting key/lamp pair, there will be two indications of a message waiting:

- the red Message Waiting LED lights
- the LCD associated with the Message Waiting key blinks

Autodial key

You can assign an Autodial Key that dials the message center (or voice mail system) to avoid the double indication or have no key/lamp pair assigned to the message center.

Programmable Feature keys

Each Meridian digital telephone has a number of programmable keys with LCD indicators that can be assigned to any combination of directory numbers and features. The M3820 has 13 fully programmable feature keys; the M3310 has seven, and the M3110 has eight. The lower right-hand key (key 0) is reserved for the Primary DN.

LCD indicators support four key/LCD states:

Function	LCD state
idle	off
active	on (steady)
ringing	flash (60 Hz)
hold	fast flash (120 Hz)

Note: Note: An indicator fast flashes when you have pressed a feature key but have not completed the procedure necessary to activate the feature.

Software requirements

Meridian digital telephones are supported by software. The package number for the Meridian digital telephones is (170.) The mnemonic is ARIE. The DSET package (88) and the TSET package (89) are required.

Terminal options

This section describes the options available for Meridian european digital telephones. [Table 102 "Hardware features and options" \(page 383\)](#) lists the features and optional hardware available for each telephone.

Table 102
Hardware features and options

	M3820	M3310	M3110
Programmable Feature keys	13	7	8
Handsfree microphone	x	x	
Optional hardware available:			
Note: In this table, x indicates available features for the telephone type listed in the top row.			

Table 102
Hardware features and options (cont'd.)

	M3820	M3310	M3110
Key Expansion Module	x		
Meridian Communications Adapter (MCA)	x	x	x
External alerter interface	x	x	x
Brandline insert	x	x	x
Note: In this table, x indicates available features for the telephone type listed in the top row.			

Meridian External Alerter and Recording Interface

The External Alerter Board provides an interface to standard remote ringing devices, such as a ringing unit, installed in a location separate from the telephone. The Meridian External Alerter and Recording Interface (MEARI) is not the remote ringer itself, but provides access to standard, off-the-shelf remote ringing devices. The Alerter Board requires additional power. See [“Power requirements” \(page 396\)](#).

You can program the MEARI interface to activate a ringer (or light) when the telephone rings or when the telephone is in use (off-hook). A call to any DN configured on the telephone triggers the alerter. The MEARI alerts to one active call at a time; if the telephone is already active on a call, a second call will not activate MEARI.

For information on installing and setting up the External Alerter, see "Add-on modules" in [“External Alerter Board” \(page 337\)](#).

Brandline Insert

The telephone contains a removable insert designed to accommodate custom labeling. You can order blank Brandline Inserts and have a printer silkscreen your company logo on them.

Key Expansion Module

A 22-key unit module can be attached to any M3820 terminal. The extra keys can be assigned to any combination of lines and features. You can add up to two expansion modules to a terminal. You will need a separate footstand for the module(s), one for a single module, one for a double.

Meridian Communications Adapter

The Meridian Communications Adapter (MCA) lets you connect your telephone to a personal computer or terminal. You can then use your telephone to exchange data between your computer and other computers. The MCA can be used with all three models.

Configuration and installation
Configuration

Use LD 11 (Meridian Digital Telephone Administration) to configure the telephones. All prompts are defaulted (or set as required) except for those noted in the tables following:

Table 103
LD 11 - M3110 Configuration

Prompt	Response	Description
REQ	NEW	
TYPE	2616	M2616 set model used
DES	M3110	Enter appropriate set identifier
CLS	HFA (HFD)	Group Listening Allowed (Denied)
KEY 08	NDD	No digit display
	NUL	Keys 8-14 programmed as NUL. If Group Listening is denied (CLS HFD), Key 15 is also programmed as NUL.
	09 NUL	
	10 NUL	
	11 NUL	
	12 NUL	
	13 NUL	
	14 NUL	
If Group Listening is denied (CLS HFD), Key 15 is also programmed as NUL.		

Figure 97
M3110 Key Designation

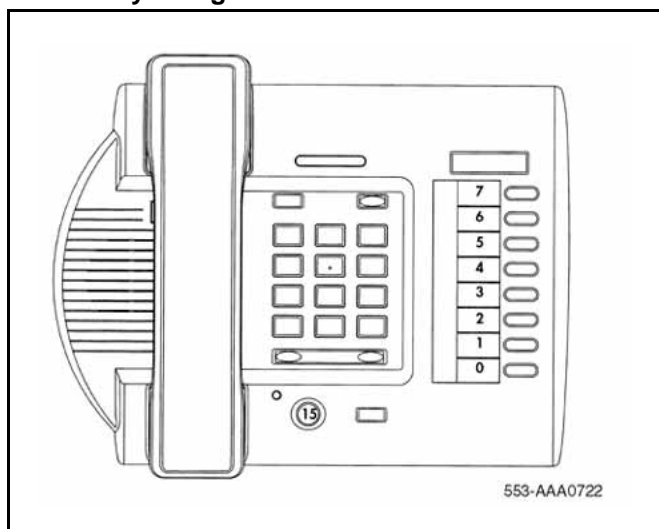

Table 104
M3310 Configuration

Prompt	Response	Description
REQ	NEW	
TYPE	2616	M2616 set model used
DES	M3310	Enter appropriate set identifier
CLS	HFA (HFD)	Handsfree Allowed (Denied)
KEY	08 NUL	Keys 8-14 programmed as NUL. If Handsfree is denied (CLS HFD), Key 15 is also programmed as NUL.
	09 NUL	
	10 NUL	
	11 NUL	
	12 NUL	
	13 NUL	
	14 NUL	

Figure 98
M3310 Key Designations

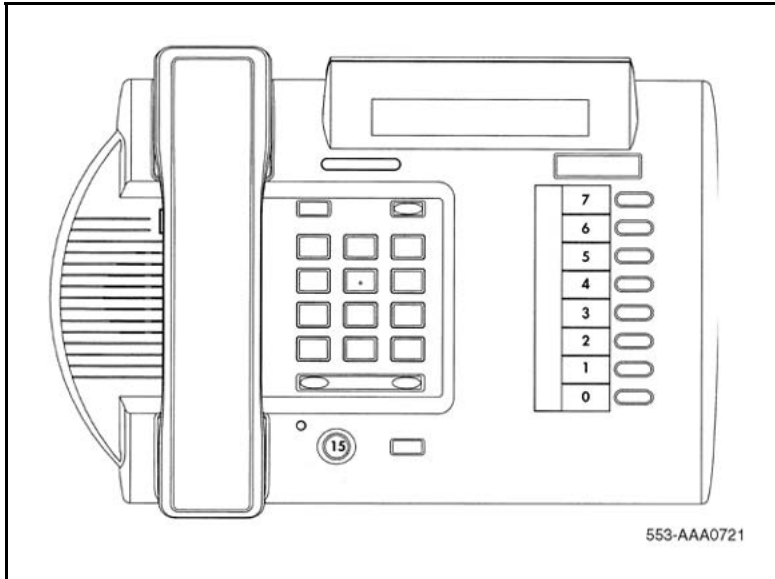

Table 105
M3820 Configuration

Prompt	Response	Description
REQ	NEW	
TYPE	2616	M2616 set model used.
DES	M3820	Enter appropriate set identifier.
CLS	HFA (HFD)	Handsfree Allowed (Denied)
	AHA	Automatic Hold Allowed
	DNDD	Dialed Name Display Denied
	CNDA	Call Party Name Display Allowed
	CNIA	Call Number Information Allowed
	LNA	Last Number Redial Allowed
KEY	01 NUL	Keys 01 programmed as NUL. If Handsfree is denied (CLS HFD), Key 15 is also programmed as NUL.
		Note: If short hunt is configured, then Key 01 must be configured as an SCR key with the same DN as key 0. For MARP to operate with short hunt configured, Key 01 must be configured as the MARP key.

Figure 99
M3820 Key Designations

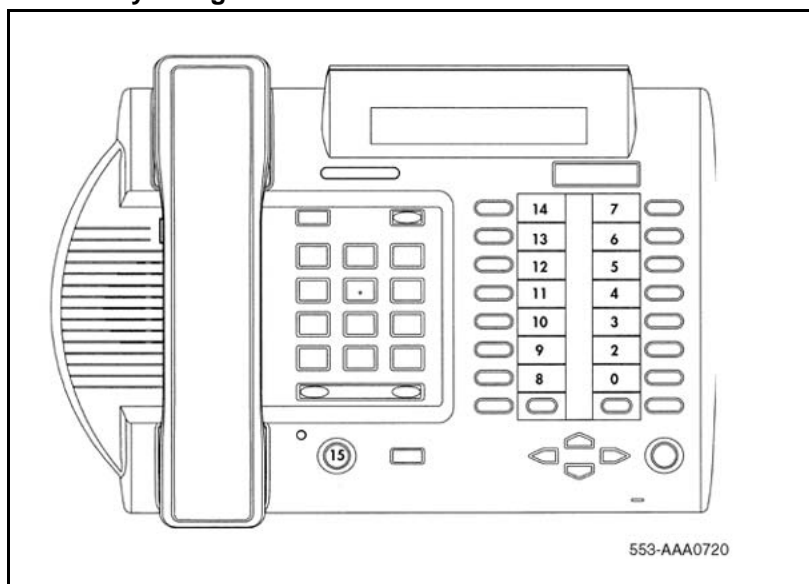

Table 106
LD 20, Print Routine

Prompt	Response	Description
REQ	PRT	
TYPE	2616	M2616 set model used.
DES	M3110	Enter appropriate set identifier Or M3+ to get a list of all three set types.
	M3310	
	M3820	
	M3+	

Installation

Procedure 81

Installing Meridian European digital telephones

Step	Action
------	--------

Follow this procedure to install the Meridian European digital telephones:

- | | |
|---|----------------------------------------------------------------------------------------------------------------------|
| 1 | Complete the wiring and cross-connections (loop power) before connecting the telephone to the connecting block. |
| 2 | Place the telephone on the desk in the normal operating position. |
| 3 | Place the RIs and Hold key caps on their positions just above the dialpad, with the Hold key closest to the handset. |

- 4 Print the directory number on the designation card. Remove the number lens from its position underneath the handset, insert the designation card and snap the lens into place.
- 5 Print the feature keys on the label strip. Remove the label lens (beside the feature keys), insert the label strip and snap the lens into place.
- 6 Plug the line cord connector into the connecting block.
- 7 Perform the self test and acceptance procedures for Meridian Modular telephones (see [Procedure 62 "Meridian Modular Telephones self-test"](#) (page 288).
- 8 Supply the user with a quick reference card.

--End--

Installing hardware options

This section describes procedures for installing the following options:

- Power Board on all models.
- Headset on M3310 and M3820 telephones.
- Wallmount/Desktop Position change.

For installation of other options (MCA data option, external alerter and key expansion modules) see the section on Add-on modules for Meridian Modular Telephones (NT2K models) in ["Meridian Modular Telephones add-on modules installation"](#) (page 299).

Procedure 82 Installing the Power Board

Step	Action
1	Open the Telephone. <ol style="list-style-type: none"> a Place the telephone, upside-down, on a padded, level surface. b Using a #1 Phillips screwdriver, remove the two screws holding the footstand (if fitted). c Disconnect and remove all cords including the handset and headset if fitted, from the telephone. d Use a #1 Phillips screwdriver and remove the four screws holding the base of the telephone.
2	Install the Power Board. <ol style="list-style-type: none"> a Remove the cable from the power board including the right angle header.

- b Disconnect the display cable from P4 on the main PCB. Note the orientation of this connector.
- c Place the power board to the left of the main PCB with the widest section of the power board nearest the display. Make sure that the display cable comes over the power board.
- d Clip the power board in place, by inserting the right hand side of the board under the clip, then push down on the left hand side adjacent to the clips provided.
- e Use a #1 Phillips screwdriver and the screw supplied to fasten the power board to the front cover of the telephone.
- f Remove and discard the two links on J8 on the telephone's main PCB.
- g Connect the power board cable (B0247405) to J8.
- h Note the key to prevent misconnection.
- i Connect the cable to the header at H1 on the power board as shown in the figure below).
- j Reconnect the display cable to P4.

Note: Do NOT twist the cable.

3 Reassemble the Telephone.

- a Replace the base cover and make sure that the cables lie flat.
- b Insert the four screws to secure the base.
- c Assemble the MCA to the footstand using the two screws provided.
- d Connect the cable to the 8 way jack on the base of the telephone.
- e Reconnect all cords to the telephone.
- f Replace the footstand with the two screws (if previously fitted).
- g Place the power board label on the footstand for tracking purposes.

--End--

Figure 100
Power Board Installation

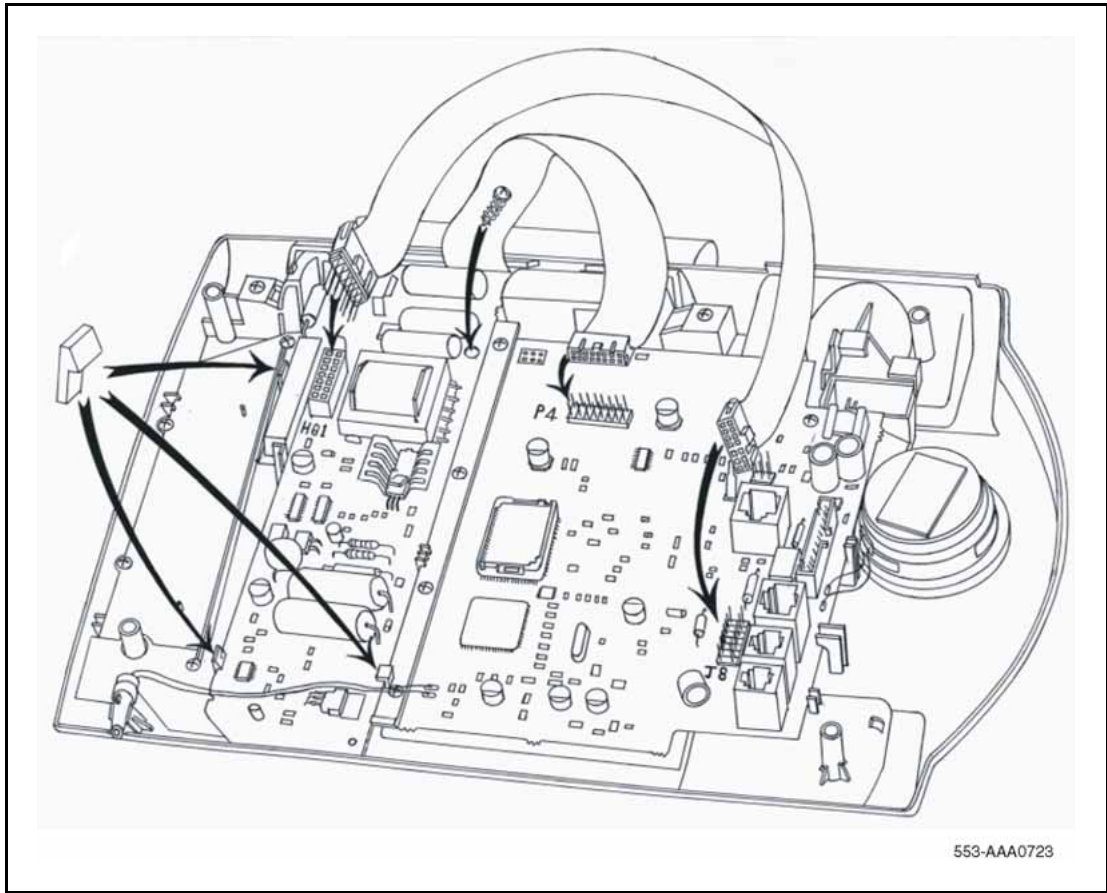

Procedure 83
Adding a Headset (M3310 and M3820 only)

Step	Action
<i>Use the following procedure to add a headset to a Meridian telephone:</i>	
1	Unplug the line cord from the connecting block.
2	Remove the handset and place the telephone upside down on top of a level, solid work surface covered with soft material or paper to prevent damage to moveable keys and the telephone face.
3	Remove the 2 screws from the telephone footstand (if fitted) to separate the footstand from the telephone.
4	Plug the headset TELADAPT connector into the socket on the base of the telephone marked with a headset icon.
5	Route the headset cord through the channels at the side of the telephone.

- 6 Replace the footstand in the same position and tighten both screws (if previously fitted).
- 7 Place the telephone back on the desk in the normal operating position.
- 8 Plug the line cord connector back into the connecting block.

--End--

Telephone Positions

Your Meridian telephone can be installed in three different positions - two desktop positions and a wall-mount position. The two desktop positions provide two different angles for the telephone on the desktop. The telephone is supplied in the steeper of the two positions. Follow [Procedure 84 "Adjusting the telephone to the desktop shallow-angle position"](#) (page 392) for adjustment to the shallow-angle position, and [Procedure 85 "Wall mounting the telephone"](#) (page 393) for wall mounting.

Procedure 84 Adjusting the telephone to the desktop shallow-angle position

Step	Action
------	--------

- The procedure to change to the more shallow angle is as follows:*
- 1 Unplug the line cord from the connecting block.
 - 2 Remove the handset and place the telephone upside down on top of a level, solid work surface covered with soft material or paper to prevent damage to moveable keys and the telephone face.
 - 3 Remove the 2 screws from the telephone footstand (if fitted) to separate the footstand from the telephone.
 - 4 Snap the footstand back into place using the alternate slots located closer to the back of the set and tighten the screws (if previously fitted).
 - 5 Place the telephone back on the desk in the normal operating position.
 - 6 Plug the line cord connector back into the connecting block.

--End--

Procedure 85
Wall mounting the telephone

Step	Action
------	--------

The procedure to wall mount the telephone by reversing the footstand is as follows:

- | | |
|---|---------------------------------------------------------------------------------------------------------------------------------------------------------------------------------------------|
| 1 | Unplug the line cord from the connecting block. |
| 2 | Remove the handset and place the telephone upside down on top of a level, solid work surface covered with soft material or paper to prevent damage to moveable keys and the telephone face. |
| 3 | Remove the 2 screws from the telephone footstand (if fitted) to separate the footstand from the telephone. |
| 4 | Remove the wall-mount clip located inside the footstand and insert the clip in the switchhook rest using the holes provided. |
| 5 | Rotate the footstand 180 degrees, snap the footstand back into place and tighten the screws. Note that the footstand must be screwed to the base for wall mounting. |
| 6 | Mount the telephone on the wall using the wall-mount holes provided on the bottom of the footstand. |
| 7 | Plug the line cord connector back into the connecting block. |

Note 1: The footstand cannot be reversed when the MCA data option or key expansion module is equipped so such telephones cannot be wall mounted.

Note 2: An additional clip is provided for wall mounting the telephone. This clip is attached to the switchhook rest to prevent the handset from slipping when mounted on the wall.

--End--

Specifications

This section lists the specifications required for Meridian digital telephones.

Environmental and safety considerations

All Meridian digital telephones are designed to comply with:

EN 60950:1992 - Safety of Information Technology Equipment including Electrical Business Equipment.

EN 41003:1993 - Particular Safety Requirements for Equipment to be connected to Telecommunication Network.

Temperature and humidity

Operating state:

Temperature range 0° to 50°C (32° to 104°F)
 Relative humidity 5% to 95% (noncondensing). At temperatures above 34°C (93°F) relative humidity is limited to 53 mbar of water vapor pressure.

Storage:

Temperature range -50° to 70°C (-58° to 158°F)
 Relative humidity 5% to 95% (noncondensing). At temperatures above 34°C (93°F) relative humidity is limited to 53 mbar of water vapor pressure.

Electromagnetic interference

All the digital telephones are designed to comply with:

EN 50082-1:1992 - Electromagnetic Compatibility - Generic immunity standard Part 1: Residential, commercial and light industry.

EN 50081-1:1992 - Electromagnetic Compatibility - Generic emissions standard. Generic standard class: Residential, commercial and light industry.

Line engineering

Meridian digital telephones use twisted pair wiring on transmission lines selected by the rules given in ["Digital telephones line engineering" \(page 223\)](#). The maximum permissible loop length is 3500 ft. (1067 m), assuming 24 AWG (0.5 mm) standard twisted wire with no bridge taps. A 15.5 dB loss at 256 kHz defines the loop length limit. (Longer lengths are possible, depending on the wire's gauge and insulation.) [Table 107 "Loop lengths for Meridian digital telephones" \(page 394\)](#) gives detailed information on loop lengths.

Table 107
Loop lengths for Meridian digital telephones

	QPC578 A and B	QPC578 C +	NT8D02
PVC insulated cable (polyvinyl chloride)			
Note 1: No bridge taps or loading coils are allowed.			
Note 2: Effect of line protector at MDF reduces loop length by 500 ft.			

Table 107
Loop lengths for Meridian digital telephones (cont'd.)

	QPC578 A and B	QPC578 C +	NT8D02
22 or 24 AWG	100–3000 ft. (30.5–915 m)	0–3500 ft. (0–1067 m)	0–3500 ft. (0–1067 m)
26 AWG	100–2100 ft. (30.5–640 m)	0–2600 ft. (0–945 m)	0–2600 ft. (0–793 m)
Note 1: No bridge taps or loading coils are allowed.			
Note 2: Effect of line protector at MDF reduces loop length by 500 ft.			

Note: Use only the line cord provided with the telephone. Using a cord designed for another telephone could result in damage to the cord.

Local alerting tones

Each telephone provides four alerting tones and a buzz sound. The system controls the ringing cadence by sending tone-ON and tone-OFF messages to the telephone. The alerting tone cadences cannot be changed from the telephone but can be altered for individual terminals by software controlled adjustments in the system. See *Software Input Output Administration (NN43001-611)* (). All other telephone tones, such as dial tone or overflow, are provided by the CS 1000 and Meridian 1 systems from a Tone and Digit Switch.

Alerting tone characteristics

The tone frequency combinations are as follows:

Tone	Frequencies	Warble Rate (Hz)
1	667 Hz, 500 Hz	5.2
2	667 Hz, 500 Hz	2.6
:		
3	1600 Hz, 2000 Hz	5.2
4	1600 Hz, 2000 Hz	2.6
:		
3	333 Hz, 250 Hz	5.2
4	333 Hz, 250 Hz	2.6

A 500 Hz buzz signal is provided for incoming call notification while the receiver is off-hook.

Power requirements

The Meridian digital telephones are loop powered. Loop power, originating in the ISDLC or the DLC, consists of a 30 V DC power source and assumes a 3500 ft. (1219 m) maximum loop length of 24 AWG (0.5 mm) wire and a minimum 15.5 V DC at the telephone terminals.

Note: The loop length limit is defined by a 15.5 dB loss at 256 KHz. Longer lengths can be determined using the wire's gauge and insulation.

Some configurations of telephones and options need more than basic loop power to operate. [Table 108 "Power requirements, Meridian digital telephones" \(page 396\)](#) lists the types of Meridian digital telephones and shows when additional power is needed to operate the telephone or its optional hardware. Power Supply Boards come installed in factory-assembled configurations that require additional power.

Note: If a power failure occurs, configurations that require loop power will continue to work only if the system has battery backup. Only those options that require additional power will cease to function.

Table 108
Power requirements, Meridian digital telephones

Telephone type	Loop power	Additional power (Power Supply Board)
M3820	Terminal, handsfree, headset, key expansion	MCA, External Alerter Interface
M3310	Terminal, headset, handsfree	MCA, External Alerter Interface
M3110	Terminal	MCA, External Alerter Interface

Power supply board

The power supply option consists of a power supply board that mounts inside the telephone, coupled with an external wall-mount transformer or closet power supply that provides power to the power supply board. The power supply board receives its power through pins 1 and 6 of the line cord.

The power supply board connects to the telephone through a 14-pin bottom entry connector.

Local plug-in transformer

A single winding transformer equipped with a 10 ft. (3 m) cord of 22 AWG two-conductor stranded and twisted wire with a modular RJ-11 duplex adapter can provide the additional power needed to operate the telephone and its options.



WARNING
Do not plug any equipment other than the terminal into the RJ-11 transformer adapter, as damage to equipment can result.

Figure 101
Configuration of local plug-in transformer

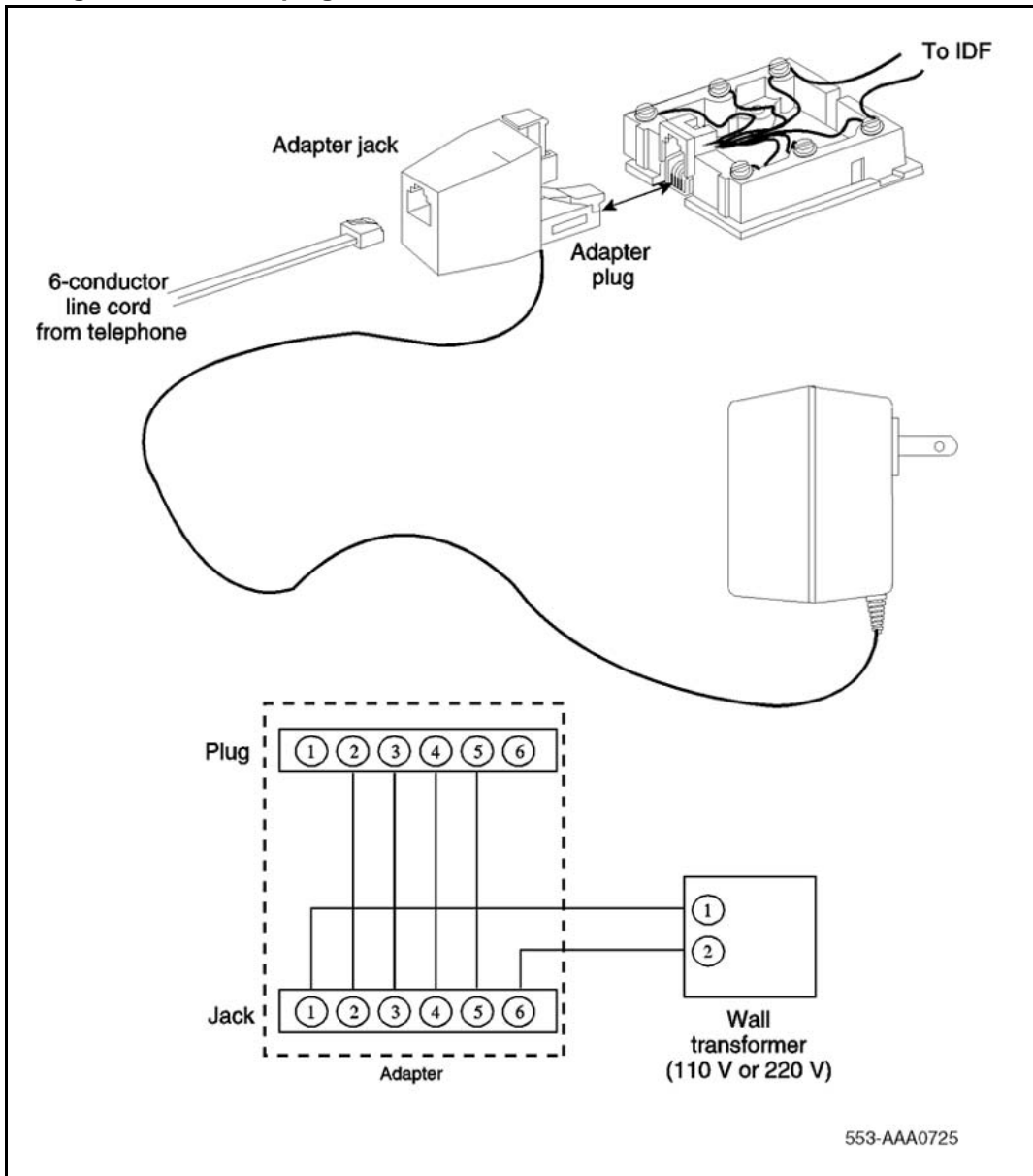

120 V transformer The following minimum specifications must be met by this transformer:

Input voltage	120 V AC/60 Hz
No load output voltage	29 V AC maximum
Voltage at rated current	26.7 V AC minimum
Rated load current	700 mA

240 V transformer The following minimum specifications have to be met by this transformer:

Input voltage	240 V AC/50 Hz
No load output voltage	29 V AC maximum
Voltage at rated current	26.7 V AC minimum
Rated load current	700 mA

Note 1: You cannot wall mount the telephone over the wall jack when using a transformer because of the size of the RJ-11 adapter. Hang it above or to the side of the jack and run the line and power cords to it.

Note 2: The above-mentioned transformers can also be used with outlets identified as 110V or 220V.

Closet Power Supply

Closet power can be obtained from an AC transformer for loops of 100 ft. (30 m) or less, or a DC transformer for loop lengths of 650 ft. (198 m) or less. An equivalent power source can be used but must be UL listed to provide isolation of outputs to the terminal. See [Figure 102 "Closet Power Supply configuration"](#) (page 399).

	<p>WARNING</p> <p>When using closet power, do not plug the TELADAPT connector into any equipment other than the Meridian digital telephone, as damage to equipment may result.</p>
-------------------------------------------------------------------------------------	-------------------------------------------------------------------------------------------------------------------------------------------------------------------------------------------

Note 1: All terminals must be isolated from the input winding and each terminal must be isolated from all other terminal windings. A separate winding is required for each terminal, and grounds must not be connected.

Note 2: The QUT1 closet power supply source is not compatible with Meridian digital telephones.

The AC source must be rated at 29 V AC, 700 mA isolated. The DC source must be rated at 42 V DC, 300 mA isolated, with current limiting output of 1 amp.

Figure 102
Closet Power Supply configuration

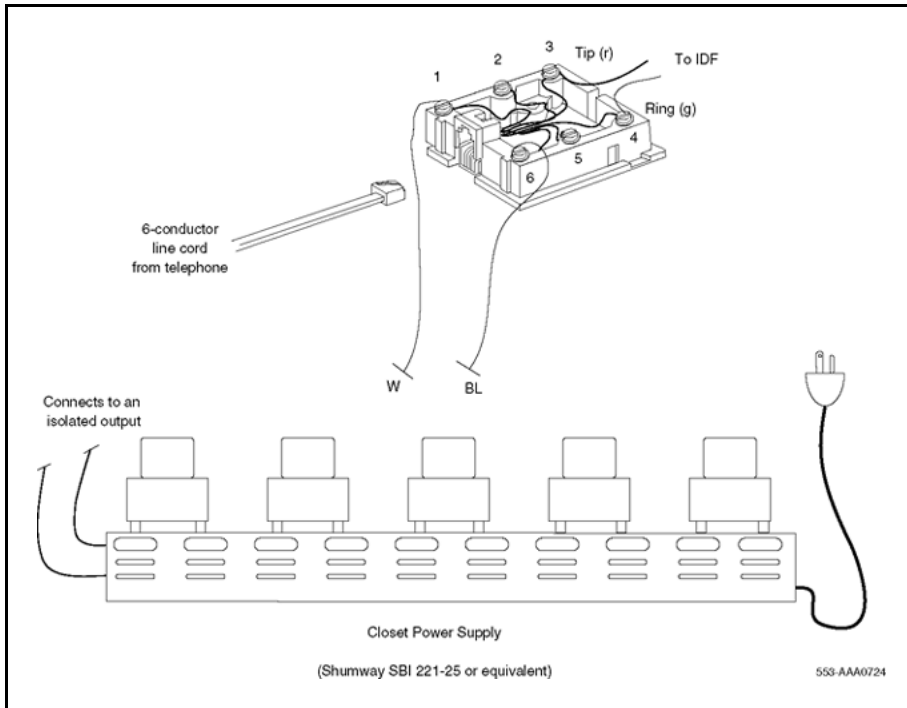

Index

- 16/25-pair cables
 - attendant console connections 43
 - terminal connections 43
- 500/2500 telephones
 - connecting 246
 - cross-connecting 247, 249–250
 - designating 244
 - installing 243
 - removing 244
 - wiring 247
- A**
- A connectors (IPE) 250
- A0288529 jumpers 321
- A0300752 cable 312
- A0300753 cable 312
- A0346862 line cords 300
- A0367601 transformers 29
- A0408927 cable 312
- A0408928 cable 312
- ACPND (Attendant Call Party Name Display) feature 71
- Active Call Failover 98
- active state
 - M3820, M3310, M3110 383
 - Meridian Modular Telephones 81, 264
- Active status message 39
- add-on modules
 - BLF/CGM 20
 - Data Options 346
 - External Alerter Boards 337
 - Key Expansion Modules 340
 - key/lamp 300
 - packing and unpacking 300
 - power supply boards 317, 324
 - troubleshooting 351
 - wall mounting 350
- ADM terminals 348
- ADO (Asynchronous Data Option)
 - Apple Macintosh connections 349
 - described 343, 346
 - external power supply 345
 - for M2317 360, 370
 - operating parameters 344
 - power supply connections 349
 - RS-232-C connectors 348–349
- AK keystrip 58
- Alarm indicators 74
- Alerter
 - adjusting speaker volume 37, 60
 - menu 66
 - testing pitch/volume levels 64
- alerting tones
 - M3820, M3310, and M3110 telephones 395
- Amphenol connectors 41
- Analog Terminal Adapter (ATA) 117, 304
 - description 302
- Apple Macintosh computers 348–349
- ASIP
 - Audio and System Interface Printed circuit card 63
- ASIP card
 - control gate 66
 - hard reset 66
 - testing installed firmware 65
- ASM (Attendant Supervisory Module)
 - add-ons 29
 - Data Options 346
 - installing 29
 - standoffs 31–32
- ATA (Analog Terminal Adapter) 302
 - installing and removing 304
- Attendant Administration feature 74

Attendant Call Party Name Display
 (ACPND) feature 71

attendant consoles

- BLF/CGM 20–21
- covers 45–46
- cross-connecting 51
- designating 48
- installing 43–44
- key/lamp modules 300
- local controls 40
- loopback tests 47
- packing and unpacking 43
- removing 45
- static discharge ground connections 43
- wiring 52

Attendant End to End Signaling 73

Attendant Forward No Answer 77

Attendant Intercept display 71

Attendant Monitor 76

Attendant Supervisory Module
 (NT7G10AA) 69

attenuation, cable 240

Autodial feature 367

Automatic Logout for Virtual Office 137

auxiliary tone channel test 64

B

B connectors (IPE) 250

background noise 237

Barge-In feature 73, 77

batteries

- BLF/CGM 20
- for headsets 378

BK keystrip 58

BLF/CGM (Busy Lamp Field/Console
 Graphics Module) 20

- batteries 20
- CGM/Mode keys 38
- covers 23, 26–27
- described 19
- fastening screws 22
- installing 20
- knockout tabs 24
- removing 28
- support spacers 23
- testing functionality of 27, 64
- volume slider position 22
- with attendant consoles 53

Brandline Inserts 384

Busy Verify feature 73, 77

C

C connectors (IPE) 251

cable attenuation 240

cable lengths, maximum 233

cable markers 41

cable pairs, engineering requirements 223

cabling, under-carpet

- allowable loop length 233
- attenuation 240
- characteristic impedance 223
- requirements 223

calculating

- DC loop resistance 233
- expected pulse loss 237

Call Forward 71, 367

Call Waiting indicator 73

Call Waiting status message 39

calls

- camped-on 71
- setting maximum number of waiting 73

capacitance unbalance, testing 235

cards

- DLC (Digital Line Card) 374
- ISDLC (Integrated Services Digital
 Line Card) 374

CAS (Centralized Attendant Service) 36

CAS/History File status message 39

CCB (Collect Call Blocking) 74

characteristic impedance

- and junction loss 241
- under-carpet cabling 223

CI/CK key/lamp strips 72

CIS (Commonwealth of Independent
 States) 75

Clearing the Callers List and Redial List
 for Virtual Office 136

Clearing the Directory Services
 Password for Virtual Office 136

clock/calendar, real-time 41

closet power supplies 396, 398

conference bridge analog control gates 66

Conference key 72

conferencing feature 365

configurations 57

connecting blocks 340

connections, console 40

connectors

- attendant consoles 44–45
- IPE 250
- M2317 telephones 290

- Meridian Modular Telephones 88, 286
 - continuity, testing DC 235
 - Contrast menu 60
 - control gates, conference bridge analog 66
 - control procedure 66
 - cords
 - and TELADAPT snap-in connectors 398
 - Meridian Modular Telephones 300
 - covers
 - attendant consoles 45–46
 - BLF/CGM 23, 26–27
 - cross-connections
 - attendant consoles 51
 - M2317 telephone 292
 - Meridian Modular Telephones 94
 - custom labeling (logos) with Brandline Inserts 384
- D**
- data calls capability 366
 - data channels 374
 - data communication failures
 - M2317 telephone 293
 - Data Options 346
 - data parameters, MCA 312
 - data port 63
 - data terminals
 - connections 317, 349
 - installing 348
 - RS-232-C connectors 349
 - Dataport option 47
 - DC loop resistance
 - calculating 233
 - maximum 232
 - measuring 241
 - dead telephones, troubleshooting 352
 - designations
 - attendant consoles 48
 - telephones 92, 244, 295
 - diagnostic tests, loop 234
 - Diagnostics menu 47
 - exiting from 60
 - password-protection 37, 60
 - selecting 37, 60
 - Diagnostics mode 61
 - Dial 0 display 71
 - dialing failures
 - M2317 telephones 294
 - digital line cards 40
 - digital lines, enabling 292
 - digital telephones
 - cross-connections 292
 - installing 290
 - packing and unpacking 285
 - self-tests 292
 - trouble-locating procedures 293
 - Displays
 - cable routing 329
 - for wall mounting 350
 - installing and removing 327, 329, 332, 337
 - troubleshooting 352
 - DLC (Digital Line Card) 374
 - DN (directory number) designation
 - window 48
 - DTI (Digital Trunk Interface) 75
 - DTMF (dual tone multifrequency) tones 73
- E**
- E connectors (IPE) 250
 - EI (Executive Intrusion) 76
 - electret headsets 378
 - electromagnetic interference
 - specifications
 - M3820, M3310, and M3110 telephones 394
 - Emergency status message 39
 - Emergency Transfer 74
 - engineering codes 17
 - engineering telephone lines
 - flowchart 225
 - procedure 223
 - environmental and safety
 - considerations
 - M2016S telephone 84
 - M2317 telephone 368
 - M3820, M3310, and M3110 telephones 393
 - M3900 telephones 142
 - Meridian Modular Telephones 273
 - Exclude Destination key 73
 - Exclude Source key 73
 - expected pulse loss, calculating 237
 - External Alerter Boards 337
 - connecting block configuration 340
 - troubleshooting 355
 - External Alerter interface 384

F

F connectors (IPE) 250
fastening screws, BLF/CGM 22
feature keys 73
 modes 59
features
 assigning to keys 73
 M2250 attendant console 18, 69
 modifying 74
 permanently assigned to keys 72
FI keystrip 72
finger wheels 245
FK keystrip
 assignable features 73
 permanently assigned features 72
flashing LCDs, troubleshooting 352
footstands 340, 342
Foreign Exchange display 71
Fully Restricted Station indication 71
function keys 36

G

G connectors (IPE) 251
garbled prompts, troubleshooting 353

H

handsets
 interfaces 158
 jack 38, 40
 options 121, 158
 volume control 38
handsfree operation
 M2317 telephone 361
 M3820, M3310, and M3110
 telephones 383
 Meridian Modular Telephones 265
headsets
 electret 378
 interfaces 123, 378
 jack 38, 40
 volume control 38
Hold key 72
hold state
 M3820, M3310, M3110 383
 Meridian Modular Telephones 81, 264

I

ICI (Incoming Call Indicator) keys 69

 assignments 71
 QMT mode enabled/disabled 58
 selecting calls 72
ICS procedure 63
idle state
 M2016S telephone 81
 M2317 telephone 363–364
 M3820, M3310, M3110 telephones 383
 Meridian Modular Telephones 264
Idle status message 39
impedance, cable characteristic
 under-carpet cabling 223
 vs. junction loss 241
impulse noise
 measuring 236
 vs. loop loss 238
incoming calls
 answering 71–72
 indication 58
 queuing 72
installation
 ATA (Analog Terminal Adapter) 304
insulation resistance, testing 235
Integrated Alarm Management 75
Intelligent Peripheral Equipment (IPE)
 cross-connections 247, 249–250
 shelf 374
Intercom 365
ISDL (Integrated Services Digital Line
 Card) 40, 374
ISDL failures
 M2317 telephones 294

J

jacks
 and TELADAPT snap-in connectors 398
 for headsets 378
jumpers 321
junction loss
 determining 239
 vs. cable characteristic impedance 241

K

K connectors (IPE) 250
key clicks, adjusting 41
key designations 48
Key Expansion Modules 340
 connections 343
 for wall mounting 350

- installing and removing 341
- troubleshooting 354
- key location codes 62
- Key-based Accessory module 120
- key/lamp add-on modules 300
- key/lamp strips
 - functions 72
 - program mode 74
- keyboard
 - layout 36
 - testing key functionality 62
- keys
 - stuck (M2250 console) 67
- knockout tabs, BLF/CGM 24

L

- L connectors (IPE) 250
- Lamp Field test procedures 27, 64
- lamp tests 62
- languages 41
- LCD display screen
 - contrast 40
 - description 18
 - languages available 41
 - messages 39
 - softkey alternate functions 60
 - softkey functions 36
 - testing alphanumeric functionality 65
- LCD indicators 39
 - M2317 361
 - M3820, M3310, M3110 383
- LCDs, flashing, troubleshooting 352
- LD 12 program 39, 47
- LD 15 program 58
- LD 31 (verification testing) 65
- LD 32 program 291
- Level 1 mode, accessing 60
- line circuit card terminations 93, 247, 296
 - attendant consoles 51, 53
- line cord requirements 358
- line cords
 - Meridian Modular Telephones 300
- Listed Directory Numbers display 71
- logos with Brandline Inserts 384
- Loop Keys/Lamps
 - described 72
 - LCD indicators 39
- loop length
 - M2250 attendant console 43
- loop power failures 293

- loopback tests 47, 63
- loops
 - diagnostic tests 234
 - distances vs. AWG 223
 - requirements 232
 - selecting 232
- loss, loop
 - maximum allowable 232
 - vs. impulse noise counts 238

M

- M connectors (IPE) 251
- M2006 Meridian Modular
 - Telephones 259, 300
 - External Alerter Boards 337
 - installing 88, 286
 - Power Supply Boards 317, 325
 - wall mounting 350
- M2008 Meridian Modular
 - Telephones 259, 300
 - displays 332
 - External Alerter Boards 337
 - installing 88, 286
 - Power Supply Boards 317, 325
 - wall mounting 350
- M2016S Meridian Modular Telephones 300
 - diagram 302
 - displays 327, 329, 337
 - installing 88, 286
 - Power Supply Boards 319
 - wall mounting 350
- M2216ACD Meridian Modular
 - Telephones 259, 300
 - diagram 302
 - displays 327, 329, 337
 - installing 88, 286
 - Key Expansion Modules 340
 - power supply boards 320
 - Power Supply Boards 319
- M2250 attendant console
 - BLF/CGM 21
 - covers 45–46
 - cross-connecting 53–54, 56
 - displaying number of waiting calls 74
 - failure codes 67
 - features 18
 - installing 44
 - key designations 48
 - loop length 43
 - loopback tests 47

- rear/left side/bottom views 35
 - removing 45
 - static discharge ground connections 43
 - top view 34
 - M2317 data terminals
 - installing 348
 - power supply connections 349
 - RS-232-C connectors 349
 - M2317 telephone
 - cross-connections 292
 - description and illustration 357, 362
 - dimensions 368
 - environmental and safety considerations 368
 - installing 290
 - line engineering 369
 - power requirements 369
 - screens and softkeys 361
 - self-tests 292
 - software requirements 367
 - trouble-locating procedures 293
 - M2616 Meridian Modular Telephones 259, 300
 - diagram 302
 - displays 327, 329, 332, 337
 - External Alert Boards 337
 - handsfree 265
 - installing 88, 286
 - Key Expansion Modules 340
 - power supply boards 320
 - Power Supply Boards 319
 - wall mounting 350
 - M3820, M3310, and M3110 telephones 383
 - environmental and safety considerations 393
 - fixed keys 380
 - functions, connections, and interfaces 374
 - hardware features and options 383
 - line engineering 145, 394
 - local alerting tones 395
 - positions 146
 - M3900 telephones
 - add-ons 114
 - description 98
 - environmental and safety considerations 142
 - features 105
 - handset interface 158
 - headset interface 123
 - installing 146
 - key descriptions 124
 - line engineering 145
 - wall mounting 147
 - Macintosh computers 348–349
 - major alarm indication/status message 39, 74
 - MCA (Meridian Communications Adapter)
 - installing 314
 - Key Expansion Modules 341
 - troubleshooting 354, 356
 - V.35 interface 311, 313
 - measuring
 - background noise 237
 - DC loop resistance 241
 - impulse noise 236
 - Meridian External Alerter and Recording Interface 120
 - Meridian Modular Telephone add-ons
 - External Alerter Boards 337
 - power supply boards 324
 - troubleshooting 351
 - Meridian Modular Telephones 257, 282
 - cross-connections 94
 - designating 92, 295
 - display module 83, 267
 - exploded view 302
 - installing 88, 286
 - Key Expansion Module 269
 - relocating 272
 - Meridian Programmable Data Adapter 268
 - message waiting feature 382–383
 - messages, LCD display screen 39
 - microphone
 - on M3820, M3310, M3110 telephones 383
 - minor alarm indication/status message 39, 74
 - modem pooling with MCA 312
 - MPDA (Meridian Programmable Data Adapter)
 - installing 314
 - Key Expansion Modules 341
- ## N
- NE-284-74-5001 adapters
 - 500/2500 connections 247
 - terminal connections 43

- NE-47QA
 - 500/2500 connections 247
 - terminal connections 43
 - NE-625F TELADAPT plugs and jacks
 - 500/2500 connections 247
 - terminal connections 43
 - Night Service key 72
 - Night Service mode
 - entering 69
 - softkey 36
 - status message 39
 - no response, troubleshooting 353–354
 - noise measurements
 - background 237
 - impulse noise 236
 - normal call processing mode
 - accessing 59
 - exiting Position Busy mode to 69
 - normal operating ranges, wiring 43
 - NT7G10AA (Attendant Supervisory Module) 69
 - NT8D02 cards 54
- O**
- operating keys 72
 - Operating parameters for Virtual Office 137
 - operating procedures 57
 - operating ranges, wiring 43
 - Options menu
 - Contrast option 40
 - exiting from 60
 - selecting 36, 60
 - ordering information
 - codes 17
- P**
- packing and unpacking
 - add-on modules 300
 - attendant consoles 43
 - telephones 285
 - parameters, MCA 312
 - PC-based Console application 16
 - peripherals testing 63
 - PFT (Power Fail Transfer) switch 38–39
 - plugs and jacks
 - 500/2500 connections 247
 - terminal connections 43
 - Position Busy key 72
 - Position Busy mode
 - and fault conditions 78
 - entering 69
 - indication 69
 - softkey 36
 - status message 39
 - Power Fail Transfer (PFT) switch 38
 - power failures, resets after 78
 - power requirements
 - for ADO (Asynchronous Data Option) 345
 - for headsets 378, 396
 - for recording devices 123, 158, 378
 - M2317 telephone 368–369
 - M3820, M3310, M3110 telephones 396
 - power supplies and power units
 - BLF/CGM 20
 - data terminals 349
 - Key Expansion Modules 340
 - MCA and MPDA 277, 310
 - Meridian Modular Telephones 317, 324
 - Power supply boards 317, 324
 - Power Supply Boards
 - closet configuration 324
 - installing 317, 319–320, 325
 - Key Expansion Modules 340
 - MCA and MPDA 277, 310
 - removing 317, 325
 - transformers 323
 - programmable keys
 - M2317 telephones 360
 - M3820, M3310, M3110 383
 - PVC cable 274, 394
- Q**
- QBB1B
 - 500/2500 connections 247
 - terminal connections 43
 - QMT2 DIP switch 65
 - QMT2 mode
 - configuring attendant consoles for 57
 - enabling/disabling 58
 - LCD indicators 39
 - queues
 - Call Waiting indicator 73
 - removing calls from 71
- R**
- R connectors (IPE) 250
 - ranges

- wiring 43
- Recall display 71
- Release Destination key 72
- Release key 72
- RELEASE prompts, troubleshooting 353
- Release Source key 72
- relocation of Meridian Modular Telephones 272
- remote ringers 120, 384
- resetting attendant consoles
 - described 78
 - hard reset procedure 66
- ringing state
 - on
 - M2006/2008/2616/2016S/2216ACD Digital telephones 81, 264
 - on M3820, M3310, M3110 383
- RLS key
 - Meridian Modular Telephones 90, 288
- RS-232-C connectors 348–349

S

- S connectors (IPE) 250
- S status message 39
- screens
 - on M2317 358, 361
- scrolling LCD display screen 37, 60
- security codes with relocations 273
- selecting loops 232
- self-tests
 - M2317 telephone 292
- Semi-Automatic Camp-On 77
- Series Call 78
- Shift key purpose/location 38
- Signal Destination key 38, 72
- Signal Source key 38, 72
- softkeys
 - alternate functions 60
 - definitions/functions 36
 - M2317 telephones 364
- Speed Call feature 73
- Speed Call for Virtual Office 137
- Speed Calling
 - with M2317 telephones 367
- standoffs 31–32
- static discharge ground connections 43
- status messages 39
- submenus 60
- support spacers, BLF/CGM 23

T

- T connectors (IPE) 251
- TELADAPT connectors
 - 500/2500 connections 247
 - M2317 telephones 290
 - Meridian Modular Telephones 88, 286
 - terminal connections 43
- TELADAPT snap-in connectors 398
- telephone failures
 - M2317 telephones 294
- telephone lines, engineering 223
- telephones
 - Asynchronous Data Options 346
 - connecting 246
 - cross-connecting 93–94, 247, 292, 296
 - designating 92, 244, 295
 - exploded view 302
 - installing 88, 286, 290
 - key/lamp modules 300
 - packing and unpacking 285
 - power supplies 317, 319–320, 324
 - removing 244
 - self-tests 292
 - trouble-locating procedures 293
 - wall mounting 350
 - wiring 247
- temperature and humidity ranges for operations
 - M2317 telephone 368
 - Meridian digital telephones 142, 394
- temperature, cable
 - and cable attenuation 240
 - correcting for 239
- terminal connections 43
- testing
 - capacitance unbalance 235
 - DC continuity 235
 - insulation resistance 235
- tests, loop diagnostic 234
- TGB (Trunk Group Busy) indicators 69
- TGB (Trunk Group Busy) keys
 - accessing 60
 - QMT2 mode enabled/disabled 58
- Tie Trunk display 71
- time/date feature 69
- TN (Terminal Number) and relocations 272
- tones, generating 66
- transformers
 - BLF/CGM 29
 - for headsets (AC) 378

- local plug-in 396
- Power Supply Boards 323
- trouble-locating procedures
 - M2317 telephones 293
- troubleshooting Meridian Modular Telephones 351
- trunks
 - busy indication 58
 - incoming calls on tie 71
 - status indications 69

U

- User interface printed circuit card (UIP)
 - hard reset 66
 - installed firmware test 65
 - testing peripherals connected to 63

V

- V.35 interface 311, 313
- verification testing (LD 31) 65
- Virtual Office (non-networked) 135
- Virtual Office feature implementation 138
- voice channels/ports 374
- voice failures
 - M2317 telephones 294
- volume control
 - M3820, M3310, M3110 382–383
- volume slider position, BLF/CGM 22

W

- wall mount clips 350
- Wide Area Telephone Service display 71
- wiring
 - displays 329
 - installing 41
 - MCA 311
 - operating ranges 43
 - telephones and attendant consoles 52
 - terminal connections 43
 - zone cabling and conduit 41–42
- wiring and loop lengths
 - M2006/2008/2616/2016S/2216ACD
 - Digital telephones 274
 - M2317 telephone 369
 - M3820, M3310, M3110 398
 - M3820, M3310, M3110
 - telephones 394, 396
- wobbling, troubleshooting 352

Z

- Z wiring
 - 500/2500 telephones 247
 - attendant consoles 52
 - cross-connections 93, 247, 252, 296
 - terminal connections 43
 - zone cabling and conduit 42

Nortel Communication Server 1000

Telephones and Consoles Fundamentals

Copyright © 2003-2009 Nortel Networks
All Rights Reserved.

Release: 6.0
Publication: NN43001-567
Document revision: 03.01
Document release date: 11 May 2009

To provide feedback or to report a problem in this document, go to www.nortel.com/documentfeedback.

www.nortel.com
LEGAL NOTICE

While the information in this document is believed to be accurate and reliable, except as otherwise expressly agreed to in writing NORTEL PROVIDES THIS DOCUMENT AS IS WITHOUT WARRANTY OR CONDITION OF ANY KIND, EITHER EXPRESS OR IMPLIED. The information and/or products described in this document are subject to change without notice.

Sourced in Canada

Nortel, the Nortel Logo, the Globemark, SL-1, Meridian 1, and Succession are trademarks of Nortel Networks.

All other trademarks are the property of their respective owners.

