



**Installing the Avaya G650 Media  
Gateway**  
Release 5.0

03-300685  
Issue 3  
January 2008

© 2008 Avaya Inc.  
All Rights Reserved.

#### **Notice**

While reasonable efforts were made to ensure that the information in this document was complete and accurate at the time of printing, Avaya Inc. can assume no liability for any errors. Changes and corrections to the information in this document may be incorporated in future releases.

**For full support information, please see the complete document, *Avaya Support Notices for Hardware Documentation*, document number 03-600759, and the complete document *Avaya Support Notices for Software Documentation*, document number 03-600758.**

**To locate these documents on our Web site, simply go to <http://www.avaya.com/support> and search for the document number in the search box.**

#### **Documentation disclaimer**

Avaya Inc. is not responsible for any modifications, additions, or deletions to the original published version of this documentation unless such modifications, additions, or deletions were performed by Avaya. Customer and/or End User agree to indemnify and hold harmless Avaya, Avaya's agents, servants and employees against all claims, lawsuits, demands and judgments arising out of, or in connection with, subsequent modifications, additions or deletions to this documentation to the extent made by the Customer or End User.

#### **Link disclaimer**

Avaya Inc. is not responsible for the contents or reliability of any linked Web sites referenced elsewhere within this documentation, and Avaya does not necessarily endorse the products, services, or information described or offered within them. We cannot guarantee that these links will work all of the time and we have no control over the availability of the linked pages.

#### **Warranty**

Avaya Inc. provides a limited warranty on this product. Refer to your sales agreement to establish the terms of the limited warranty. In addition, Avaya's standard warranty language, as well as information regarding support for this product, while under warranty, is available through the following Web site: <http://www.avaya.com/support>.

#### **Copyright**

Except where expressly stated otherwise, the Product is protected by copyright and other laws respecting proprietary rights. Unauthorized reproduction, transfer, and or use can be a criminal, as well as a civil, offense under the applicable law.

#### **Avaya support**

Avaya provides a telephone number for you to use to report problems or to ask questions about your product. The support telephone number is 1-800-242-2121 in the United States. For additional support telephone numbers, see the Avaya Web site: <http://www.avaya.com/support>.

# Contents

<b>Chapter 1: Introduction</b> . . . . .	<b>7</b>
Audience . . . . .	7
How to use this documentation . . . . .	8
Downloading this book and updates from the Web . . . . .	8
Sending us comments. . . . .	9
Related resources . . . . .	9
Preinstallation requirements . . . . .	10
High-level overview of the installation process . . . . .	11
Installing the media gateways . . . . .	11
Cabling the media gateways . . . . .	11
Connecting the media gateways . . . . .	12
Connecting to the customer's network . . . . .	12
Installing and wiring telephones . . . . .	12
Completing the installation . . . . .	12
Testing the complete installation . . . . .	12
<b>Chapter 2: Installing and cabling the G650 Media Gateway</b> . . . . .	<b>13</b>
Overview . . . . .	13
Rack requirements. . . . .	13
Specifications . . . . .	14
Preinstallation tasks . . . . .	14
Checking the customer order . . . . .	14
Unpacking and inspecting the G650 media gateway . . . . .	15
Correcting shipping errors . . . . .	16
Precautions for AC power and ground . . . . .	17
Approved grounds . . . . .	17
Installing the G650 Media Gateway . . . . .	18
Checking the ventilation and the G650 Media Gateway rack . . . . .	20
Setting the carrier address ID . . . . .	21
Mounting one G650 Media Gateway . . . . .	23
Power supply fuse . . . . .	28
Mounting two to five G650 Media Gateways . . . . .	28
Installing the TN2312BP IPSI adapter . . . . .	29
Approved ground . . . . .	30
Connecting the G650 Media Gateway grounds and other grounds . . . . .	31
Connecting to AC power . . . . .	32
Chassis power source information for the G650 Media Gateway . . . . .	32
Connecting the power cords . . . . .	33
Required input current . . . . .	34

## Contents

Testing the AC outlet . . . . .	34
Using an ideal 61-035 Circuit Tester (or equivalent) to verify ground . . .	35
Using a VOM in the US and countries that use 110-VAC to 125-VAC power to verify voltage . . . . .	35
Plugging in AC power . . . . .	36
Connecting to DC power . . . . .	36
DC power layout . . . . .	36
Using an uninterruptible power supply . . . . .	39
Installing a UPS . . . . .	39
G650 Media Gateway power switch . . . . .	40
Cabling the G650 Media Gateways . . . . .	41
Cabling two media gateways . . . . .	42
Cabling the third media gateway . . . . .	43
Cabling the fourth media gateway . . . . .	43
Cabling the fifth media gateway . . . . .	44
Installing circuit packs in the G650 Media Gateway . . . . .	50
<b>Chapter 3: Connecting to the customer's network . . . . .</b>	<b>53</b>
TN799DP Control LAN . . . . .	53
TN2302AP IP Media Processor . . . . .	53
TN2602AP IP Media Resource 320 . . . . .	54
TN801B MAP-D LAN Gateway . . . . .	55
TN2501AP Voice Announcement over LAN (VAL) . . . . .	55
Important file specifications . . . . .	56
Caveats . . . . .	56
<b>Chapter 4: Testing the complete configuration . . . . .</b>	<b>57</b>
Testing port network equipment . . . . .	58
Checking PN status for each media gateway . . . . .	58
Checking circuit pack configuration . . . . .	58
Testing the TN2312BP IPSI circuit pack . . . . .	59
Testing bearer duplication with the TN2602AP circuit pack . . . . .	59
Testing the TDM bus for each PN . . . . .	60
Saving translations, if required . . . . .	60
Testing telephones and other equipment . . . . .	61
Making test calls . . . . .	61
Testing the 302C attendant console . . . . .	62
Testing selector console . . . . .	62

Testing external ringing . . . . .	63
Testing the queue warning indicator . . . . .	63
Testing integrated announcement . . . . .	63
Recording an announcement . . . . .	64
Playing back an announcement . . . . .	64
Deleting an announcement . . . . .	64
Testing music-on-hold . . . . .	64
Testing emergency transfer . . . . .	64
Testing terminating trunk transmission . . . . .	65
Testing connectivity to the LAN . . . . .	66
LED indicators . . . . .	66
Telephone console LEDs . . . . .	66
Attendant console LEDs . . . . .	67
Terminal alarm notification . . . . .	67
<b>Index . . . . .</b>	<b>69</b>

## **Contents**

# Chapter 1: Introduction

Use the procedures in this document to install a new Avaya G650 Media Gateway, connect it to the customer's network, and test the complete configuration.

The G650 Media Gateway provides card slots for up to 14 TN-type circuit packs, redundant, hot-swappable power supplies, and AC or DC power. The backplane can support 14 circuit packs, 2 power supplies, and provides monitoring of system fans, power supplies, and temperature. Up to five G650 Media Gateways can be mounted in an EIA-310 standard 19-inch (48 cm) rack.

To configure the various pieces of hardware, you can use either of the following administration interfaces:

- The Maintenance Web Interface
- A command line interface that uses either telnet or Native Configuration Manager

This installation document contains the following information:

- [Preinstallation requirements](#) on page 10
- [High-level overview of the installation process](#) on page 11
- [Installing and cabling the G650 Media Gateway](#) on page 13
- [Connecting to the customer's network](#) on page 53

---

## Audience

This documentation is for the following audiences:

- Trained field installers
- Technical support personnel
- Authorized Business Partners

## How to use this documentation

Use this documentation to install the G650 Media Gateway. For information about a particular task, use the index or table of contents to locate the page number where the information is described.

For an overview of the installation process, see [High-level overview of the installation process](#) on page 11.

Use the remaining sections of the document in the sequence they are presented. If certain components are not to be installed, skip the procedures for those components.

---

## Downloading this book and updates from the Web

You can download the latest version of this documentation from the Avaya Support Web site (<http://support.avaya.com>). You must have access to the Internet and a copy of Adobe Reader installed on your personal computer.

Avaya makes every effort to ensure that the information in this book is complete and accurate. However, information can change after we publish this documentation. Therefore, the Avaya Support Web site might also contain new product information and updates to the information in this book. You can also download these updates from the Avaya Support Web site.

To view any book, you must have a copy of Adobe Acrobat Reader.

**Note:**

If you do not have Acrobat Reader, you can get a free copy at <http://www.adobe.com>.

To download an electronic version of this documentation:

1. Access the Avaya Support Web site at <http://support.avaya.com>.
2. At the top of the page, click in the **Search** text box.
3. Type the documentation number 03-300685 and click the arrow button.
4. In the resulting list, locate the latest version of the document, and then click the document title to view the latest version of the book.

---

## Sending us comments

Avaya welcomes your comments about this book. To reach us by:

- Mail, send your comments to:  
Avaya Inc.  
Product Documentation Group  
Room B3-H13  
1300 W. 120th Ave.  
Westminster, CO 80234 USA
- E-mail, send your comments to:  
*document@avaya.com*
- Fax, send your comments to:  
1-303-538-1741

When commenting, be sure that you mention the name and number of this book, *Installing the Avaya G650 Media Gateway* (03-300685), as well as the issue number.

---

## Related resources

You may need the information in the following documents to perform a complete installation of servers, gateways, and associated hardware and software. These documents are included on the CD-ROM *Documentation for Avaya Communication Manager, Media Gateways and Servers*, (03-300151). You can download the contents of this CD-ROM from the Avaya Support Web site, <http://support.avaya.com>.

- *Adding New Hardware for Avaya Servers and Gateways* (03-300684). Provides information on installing adjunct and peripheral equipment that an S8400, S8500, or S8700-series Server supports.
- *Electronic Preinstallation Worksheet (EPW)*. An Excel spreadsheet that provides the customer network information that you need to configure the control network components with the Avaya Installation Wizard. Get the completed EPW from the Avaya project manager, Avaya software technician, or customer network administrator. A blank EPW is available at the AIW Web site, <http://support.avaya.com/avayaiw>.
- *Installing and Connecting the MDF and Telephones* (03-300686). Provides information on how to install the main distribution frame (MDF), connect the media gateway to the MDF, connect the MDF to stations and the public switched telephone network, install and wire telephones and trunks, install and wire telephone power supplies, and test the complete configuration.

## Introduction

- *Administrator Guide for Avaya Communication Manager* (03-300509). Provides user information on how to administer trunks and telephones.
- *Administration for Network Connectivity for Avaya Communication Manager* (555-233-504). Provides information on network connectivity.
- *Maintenance Commands for Avaya Communication Manager 5.0, Media Gateways and Servers* (03-300431). Provides information on how to use command interfaces, command syntax, and output from maintenance-related commands.
- *Maintenance Alarms for Avaya Communication Manager 5.0, Media Gateways and Servers* (03-300430). Provides information on how to use alarms, error codes, and tests to diagnose and repair problems.
- *Maintenance Procedures for Avaya Communication Manager 5.0, Media Gateways and Servers* (03-300432). Provides information on how to troubleshoot and replace various components.
- *Installing and Operating a 120A Channel Service Unit with Avaya Communication Manager* (03-601508). Provides procedures on how to install and use a 120A Channel Service Unit, which may be used in some G650 configurations.
- The following job aids are also available on the CD-ROM *Documentation for Avaya Communication Manager, Media Gateways and Servers*:
  - *Approved Grounds*. Provides a description of all approved grounds.
  - *Connector and Cable Diagrams (Pinout Charts)*. Provides pinout information for various components.
  - *Option Switch Settings*. Provides settings for various components.

For all documents associated with the S8400, S8500, S8700-series Servers, see the CD titled *Documentation for Avaya Communication Manager, Media Gateways and Servers* (03-300151).

---

## Preinstallation requirements

The preinstallation team performs the following tasks. If these are not complete when you are ready to start the installation, do not start the installation.

Verify that:

- The open, customer-supplied, EIA-310D or equivalent standard 19-inch (48-centimeter) equipment racks are properly installed and solidly secured. Ensure that you also have the screws that come with the racks.
- The rail kits, which are required to support the heavy UPSs, are installed on the rack or available for installation. For how to install the rails, see the documentation that comes with the rail kits.

- The required number of 19-inch (48-centimeter) EIA-310D open equipment racks are grounded. For more information, see *Approved Grounds*, (555-245-772).
- You have the required, customer-provided network information in the form of a completed *Electronic Preinstallation Worksheet (EPW)*. For a blank form, see the Avaya Installation Wizard Web site, <http://support.avaya.com/avayaiw>
- All the equipment is on site. Compare the list of items that were ordered to the contents of the boxes to verify that you have all the equipment. Your project manager can give you an inventory list. Do not rely on the packing slips inside the boxes for the correct information.

---

## High-level overview of the installation process

You complete the installation process in stages. You can complete some stages in parallel. Other stages require certain tasks first. The order in which you complete the stages depends on the suggested order, local practice, and the personnel available. The high-level stages are:

- Installing the G650 media gateways
- Cabling the media gateways
- Connecting to the customer network which includes servers, C-LAN, VAL, and so forth
- Installing and wiring telephones and trunks
- Completing the installation administration which includes clear alarms, enable alarm reporting, backup translation, and so forth
- Testing the complete configuration

These high-level stages are described below.

---

### Installing the media gateways

You can complete this stage in parallel with installing and configuring the server complex. You must install and turn on the media gateways before you complete many of the other stages.

---

### Cabling the media gateways

In this stage, you attach the cables of the media gateways to the main distribution frame and the patch panels. This stage usually comes after you install the media gateways and before you install traditional telephones.

### Connecting the media gateways

In this stage, you connect the media gateways to the server complex through Ethernet cables. You also program the IP Server Interface (IPSI) circuit packs during this stage. Before you can complete this stage, the G650 Media Gateway must be installed and the server complex must be operational.

---

### Connecting to the customer's network

You can perform this stage anytime. But to allow testing along the way, connect to the customer network after you cable the media gateways and connect the gateways to the server complex.

---

### Installing and wiring telephones

In this stage, you wire, place, and test the telephones. In most cases, the configuration must be operational and responsive before you can perform this stage. An exception exists for IP telephones that are connected to the network, which you can place before you complete the installation. When you install wiring for traditional telephones and analog or digital consoles, ensure that you install the telephones when you can also test the telephones.

**Note:**

The information for this stage is provided in the document, *Installing and Connecting the MDF and Telephones*, (03-300686).

---

### Completing the installation

In this stage, you finish the installation. To finish the installation, you clear alarms, enable alarm reporting, back up the servers, connect the modems and register the configuration. This stage comes at the end of the actual installation.

---

### Testing the complete installation

In this stage, you verify the complete configuration operation. Always perform this stage last.

# Chapter 2: Installing and cabling the G650 Media Gateway

---

## Overview

You usually install media gateways in the same equipment room as the server rack hardware. However, you can also install the media gateways in another location, which can include another state or country.

A port network (PN) consists of up to five G650 media gateways in a rack. The media gateway in the A location, at the bottom of the rack, contains the TN2312AP IP Server Interface (IPSI) circuit pack. One IPSI per port network is recommended. For the G650 in an S8400 Server, the TN8412AP (SIPI) may be used instead of the TN2312AP (IPSI).

**Note:**

Before you start the media gateway installation, check the location of the AC and DC power receptacles. The receptacles must be on separately fused circuits that are not controlled by wall switches. The receptacles must be located within 10 feet (3 meters) of the media gateway and outside the main distribution frame (MDF) area.

**Note:**

For convenience, install the reference IPSI in a PN that is in the same room as the control network hardware. The reference IPSI is the IPSI that is associated with the license file.



**Important:**

Before you install the media gateways, ensure that you have all the required equipment and are aware of warnings when you work around sources of power.

---

## Rack requirements

The customer must:

- Provide sturdy racks that are built to the EIA-310D standard or equivalent.
- Install, secure, and ground the racks per local code and rack specifications before the equipment is mounted in the racks.
- Provide AC power to the rack from a nonswitched outlet.

## Installing and cabling the G650 Media Gateway

You must ensure that:

- The screws that come with the rack are available.
- The rail kits, which are required to support the heavy UPSs, are installed on the rack or available for installation.

The rack must be rated at a minimum of 200 pounds (90 kilograms).

---

## Specifications

The specifications of the G650 media gateway are:

- English dimensions (in.): 14h x 22d x 17.5w
- Metric dimensions (cm): 35.6h x 56d x 44w
- Us (height in rack): 8
- Weight (lb/kg): 35 to 39/16 to 18

For more information, see *Hardware Description and Reference for Avaya Communication Manager*, 555-245-207.

---

## Preinstallation tasks

Perform these tasks before you start the installation:

- [Checking the customer order](#) on page 14
- [Unpacking and inspecting the G650 media gateway](#) on page 15
- [Correcting shipping errors](#) on page 16

---

## Checking the customer order

To check the customer order:

1. Check the customer order list and the shipping packing list to confirm that all equipment is included.
2. Check the system adjuncts for damage and report all damage according to local shipping instructions.
3. If any equipment is missing, report the information to your Avaya representative.

---

## Unpacking and inspecting the G650 media gateway

**DANGER:**

Use lifting precautions. An empty G650 Media Gateway weighs 35 to 39 pounds (16 to 18 kilograms). Use caution to avoid injury.

To unpack and inspect the G650 Media Gateway:

1. Unpack the media gateway and remove all packing material.
2. Verify the equipment received. See [Figure 1: Equipment that is shipped with a single G650 Media Gateway](#) on page 16. Actual equipment might vary in appearance and might be shipped in separate packages.

**Note:**

The optional G650 Media Gateways for port hardware only are shipped with:

- An AC or DC power cord or international power cord kit
- Mounting screw kits
- A TDM/LAN bus cable
- EMI gaskets

Figure 1: Equipment that is shipped with a single G650 Media Gateway

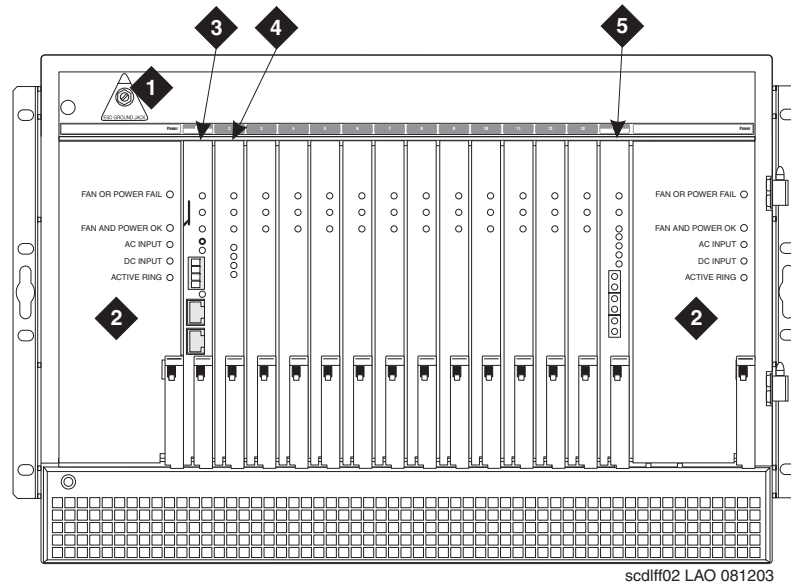

Figure notes:

- |   |   |
|---|---|
| 1. ESD ground jack  | 4. TN799DP C-LAN (optional)   |
| 2. 655A power supply  | 5. TN2302 IP media processor or<br>TN2602 IP media resource<br>(optional) |
| 3. TN2312BP IP server interface (IPSI)<br>circuit pack, or TN8412AP SIPI on<br>S8400 Server |   |

## Correcting shipping errors

To correct shipping errors:

1. Red-tag all defective and excess equipment.
2. Return equipment in accordance with instructions from the nearest Material Stocking Location (MSL).

To contact the Avaya Order Management group in the United States, call 1-800-772-5409. For international customers, contact your order service agent.

3. Report shipments that do not contain the necessary equipment to the nearest MSL. Contact the appropriate location for specific instructions.

---

## Precautions for AC power and ground

When you install media gateways, be aware of the following warnings and cautions.

 **WARNING:**

A qualified electrician must set up the ground wiring and the equipment room for alternating current (AC) power. The AC power circuit must be dedicated to the system. The circuit must not be shared with other equipment or controlled by a wall switch. The AC receptacle must not be located under the main distribution frame and must be easily accessible.

 **CAUTION:**

Media gateway grounding must comply with the general rules for grounding in Article 250 of the National Electrical Code (NEC), National Fire Protection Agency (NFPA) 70, or the applicable electrical code in the country of installation. For more information, see *Approved Grounds*, 555-245-772.

 **DANGER:**

The latch on the power supply does not turn off the power to the G650 Media Gateway. To turn off the AC power from the G650, pull the AC power cord from the back of the G650 Media Gateway. If redundant power supplies exist, you must pull both AC power cords from the back of the G650 Media Gateway. To remove DC power, first locate and switch the DC circuit breaker to the "off" position. Second, disconnect the DC power feed at the back of the G650 Media Gateway.

 **WARNING:**

If other equipment is installed in the same rack, ensure that the G650 Media Gateway does not generate an overcurrent or overload condition. Verify that the branch circuit and the power distribution strip of the customer provide sufficient overload and overcurrent protection.

## Approved grounds

For more information about grounding the G650 Media Gateway, see *Approved Grounds*, 555-245-772.

## Installing the G650 Media Gateway

This section includes the following tasks, which you must perform to install the G650 Media Gateway PN:

- [Checking the ventilation and the G650 Media Gateway rack](#) on page 20
- [Setting the carrier address ID](#) on page 21
- [Mounting one G650 Media Gateway](#) on page 23
- [Mounting two to five G650 Media Gateways](#) on page 28
- [Installing the TN2312BP IPSI adapter](#) on page 29
- [Approved ground](#) on page 30
- [Connecting the G650 Media Gateway grounds and other grounds](#) on page 31
- [Connecting to AC power](#) on page 32
- [Connecting to DC power](#) on page 36
- [Using an uninterruptible power supply](#) on page 39
- [G650 Media Gateway power switch](#) on page 40

[Figure 2: G650 Media Gateway stack \(A through E\) that is installed next to the server rack](#) on page 19 shows a typical Communication Manager installation.

Figure 2: G650 Media Gateway stack (A through E) that is installed next to the server rack

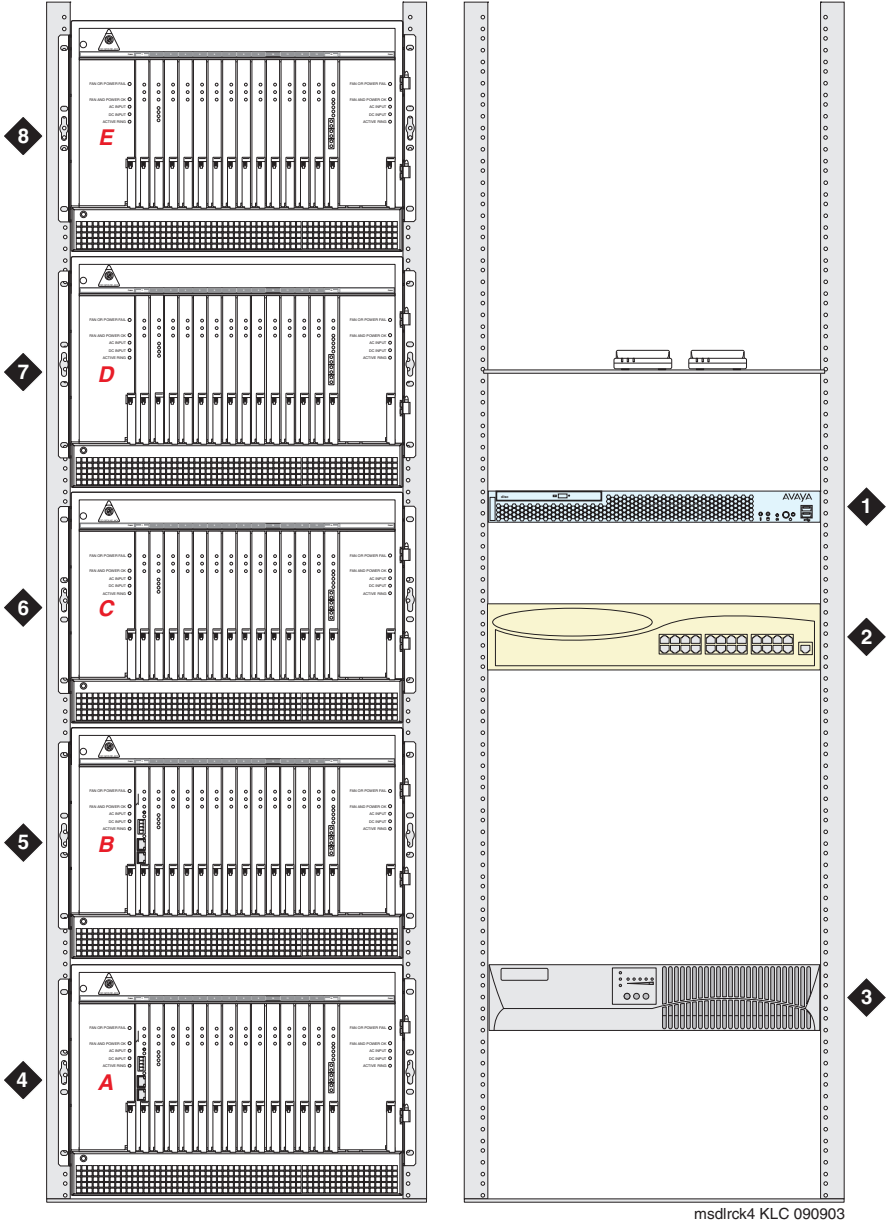

msdlrck4 KLC 090903

Figure notes:

- 1. Server 1
- 2. Ethernet switch (if used)
- 3. UPS 1
- 4. Carrier A
- 5. Carrier B
- 6. Carrier C
- 7. Carrier D
- 8. Carrier E

---

## Checking the ventilation and the G650 Media Gateway rack

**⚠ WARNING:**

Ensure that the area has adequate ventilation. The internal room temperature must not exceed 104° F (40° C).

You must install the G650 Media Gateway in a well-ventilated area. Maximum equipment performance is achieved at an ambient temperature between 40° and 120° F (4° and 49° C) for a short-term operation, not more than 72 consecutive hours or 15 days in a year, and up to 104° F (40° C) for continuous operation. The relative humidity range is 10% to 95% at up to 84 F (29° C).

For adequate ventilation and to conform with EIA-310D data rack standards, you must provide the following clearance:

- 12 inches (30 centimeters) in the rear
- 18 inches (45 centimeters) in the front
- 3 inches (7.6 centimeters) on the sides

**⚠ WARNING:**

Ensure that the customer-supplied 19-inch (48-centimeter), EIA-310D standard, open rack is properly installed. The rack must be solidly secured to the floor and grounded. If the rack is not secured to the floor, do not proceed with the installation. Avaya does not recommend that you use enclosed data cabinets. Enclosed cabinets might not allow sufficient ventilation to the G650 Media Gateway.

**⚠ WARNING:**

You must align the G650 Media Gateway with the correct holes in the frame because the distance between each hole is not uniform. Use the *G650/G600 Mounting Template* that is shipped with each carrier, to help you align the holes.

Each G650 Media Gateway is 8U high. A typical data rack is 42U high. When you create a five-carrier G650 Media Gateway stack, all but 3.5 inches (8.9 centimeters) of a typical rack is used. Mount the A carrier low in the rack.

In a multiple G650 Media Gateway configuration, put the G650s in the rack with no vertical space between them. If the G650 Media Gateways are not mounted adjacent to one another with the fronts in the same vertical plane, you cannot use the TDM/LAN cables to connect them.

---

## Setting the carrier address ID

Set the carrier address ID either before or after you install each G650 Media Gateway. To set the carrier address, insert the address paddleboard in one of five connector slots on the upper-right side of the backplane. The slots are marked as A, B, C, D, and E. Avaya ships all carriers with the address paddleboard in connector slot A. If you are working on a B, C, D, or E carrier, you must remove the address paddleboard. Then move the paddleboard to the correct slot for a B, C, D, or E carrier.

To set the carrier address ID:

1. Loosen the thumb screws on the fan assembly and pull the assembly straight out ([Figure 3: Removing the fan assembly](#) on page 22). You do not need to unplug the connection. Place the assembly on top of the cabinet or hang the assembly from the rear connector panel with the screws on the back of the assembly. Leave the fan assembly off until the unit is completely installed in the rack.
2. Verify and, if necessary, set the carrier address ID for each G650 Media Gateway ([Figure 4: Setting the carrier address ID on the G650 Media Gateway](#) on page 22). Place the address paddleboard in the connector slot that you want, either slot A, B, C, D, or E.
3. Replace the fan assembly.

**Note:**

It may be difficult to replace the fan assembly. You can use one of the lower screw-on panels as a pry tool. See [Figure 3: Removing the fan assembly](#) on page 22.

Figure 3: Removing the fan assembly

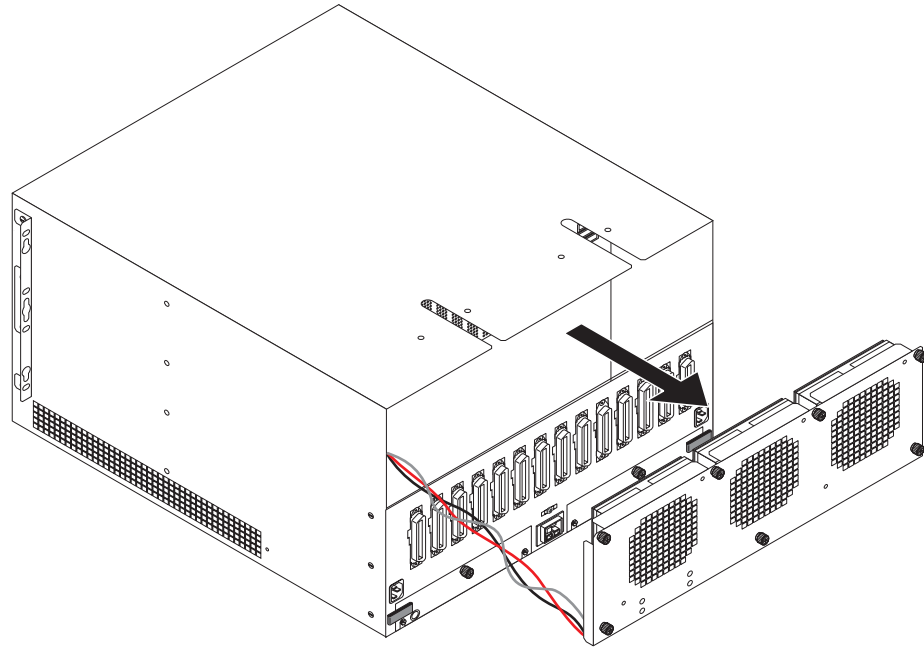

fndprem2 LAO 071503

Figure 4: Setting the carrier address ID on the G650 Media Gateway

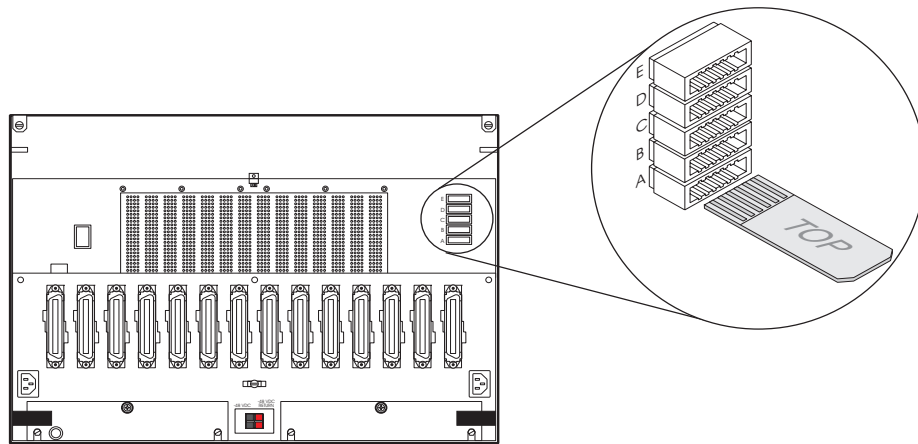

swdlpdle LAO 072403

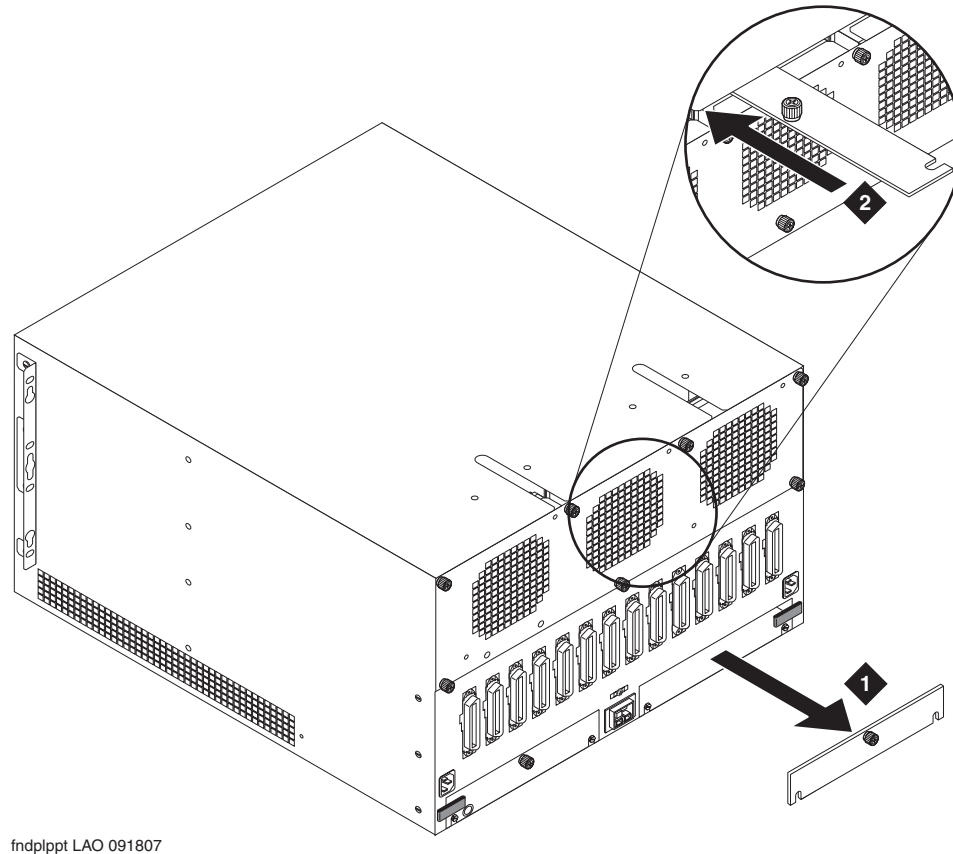
**Figure 5: Replacing the fan assembly**

## Mounting one G650 Media Gateway

**Note:**

In a multiple G650 Media Gateway configuration, put the G650s in the rack with no vertical space between them. If the G650 Media Gateways are not mounted adjacent to one another with the fronts in the same vertical plane, you cannot use the TDM/LAN cables to connect them.

**Note:**

Avaya recommends that you install the first G650 Media Gateway in the lowest position as carrier A. This position facilitates mounting carriers B through E directly above carrier A. For more information, see [Figure 2: G650 Media Gateway stack \(A through E\) that is installed next to the server rack](#) on page 19.

## Installing and cabling the G650 Media Gateway

To mount one G650 Media Gateway:

1. To remove the G650 Media Gateway door:
  - a. Open the door.
  - b. Lift the door straight up and off the hinge pins.

 **WARNING:**

When you handle circuit packs or any components of the G650 Media Gateway, always wear an authorized wrist ground strap. Ensure that the strap connects to the ground connector that the G650 provides. Always store the circuit packs to protect the circuit packs from damage by electrostatic discharge.

2. To place the G650 Media Gateway in the middle position:
  - a. Remove the screws on the mounting brackets.
  - b. Move the brackets to a position that is in the middle of the G650 Media Gateway.
  - c. Reinstall the screws through the mounting bracket and into the G650 Media Gateway holes. Tighten the knurled screws securely so that you cannot loosen them without a screwdriver.
3. Use the mounting template to locate a set of rack holes to use to mount the G650 Media Gateway. Note the position of the upper keyhole-shaped slots on each rail.

**Note:**

The mounting screw holes in commercial racks are not evenly spaced. Ensure that the holes that you select to mount the G650 Media Gateway match all the mounting bracket slots on the mounting template ([Figure 6: Placement of the holes on the rack and the first mounting screws](#)).

**Figure 6: Placement of the holes on the rack and the first mounting screws**

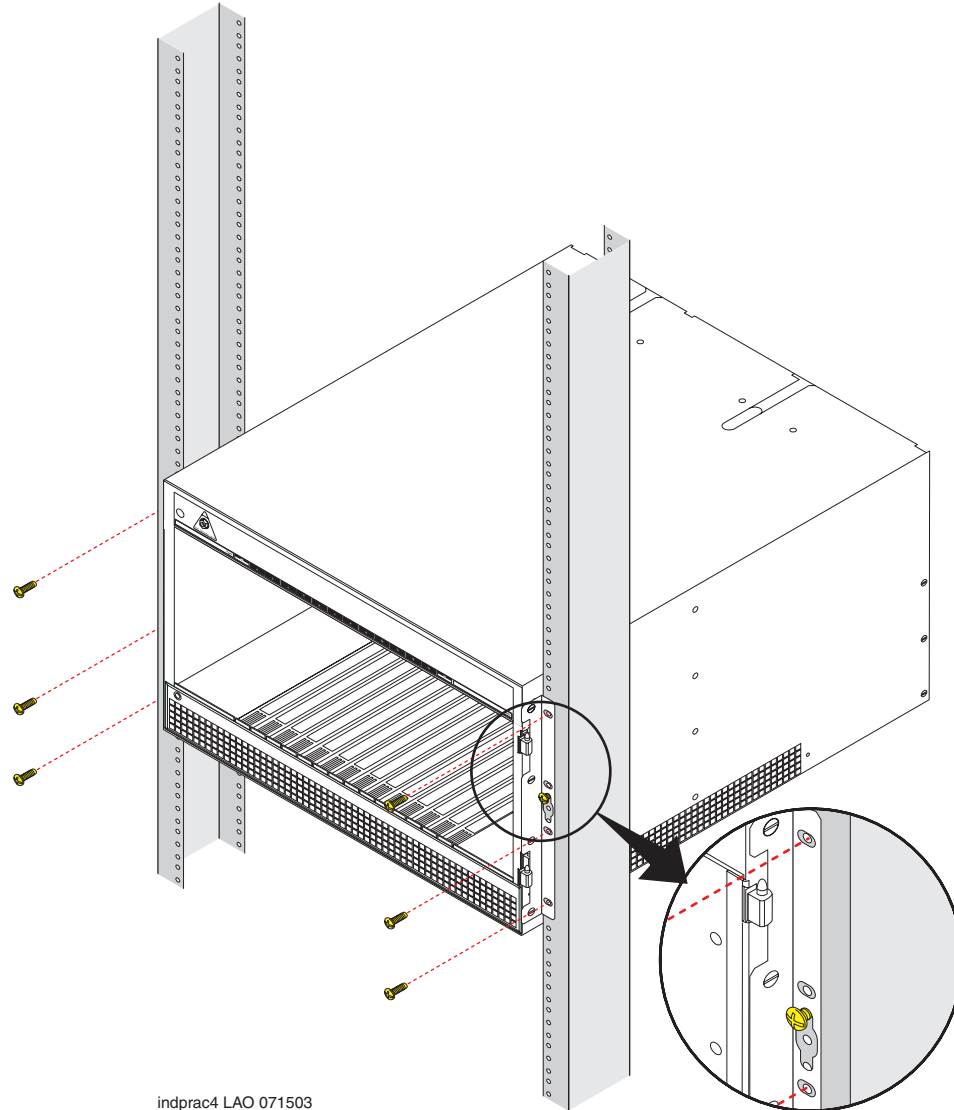

indprac4 LAO 071503

**Figure notes:**

- |                                      |                          |
|--------------------------------------|--------------------------|
| <b>1. Rack mounting hole spacing</b> | <b>2. Mounting screw</b> |
|--------------------------------------|--------------------------|

- 
4. Insert two mounting screws into the left rail and right rail of the rack in the holes that you noted in step 3. Leave enough space between the screw head and the rail surface for the mounting bracket ([Figure 7: Mounting the media gateway](#)).

**Figure 7: Mounting the media gateway**

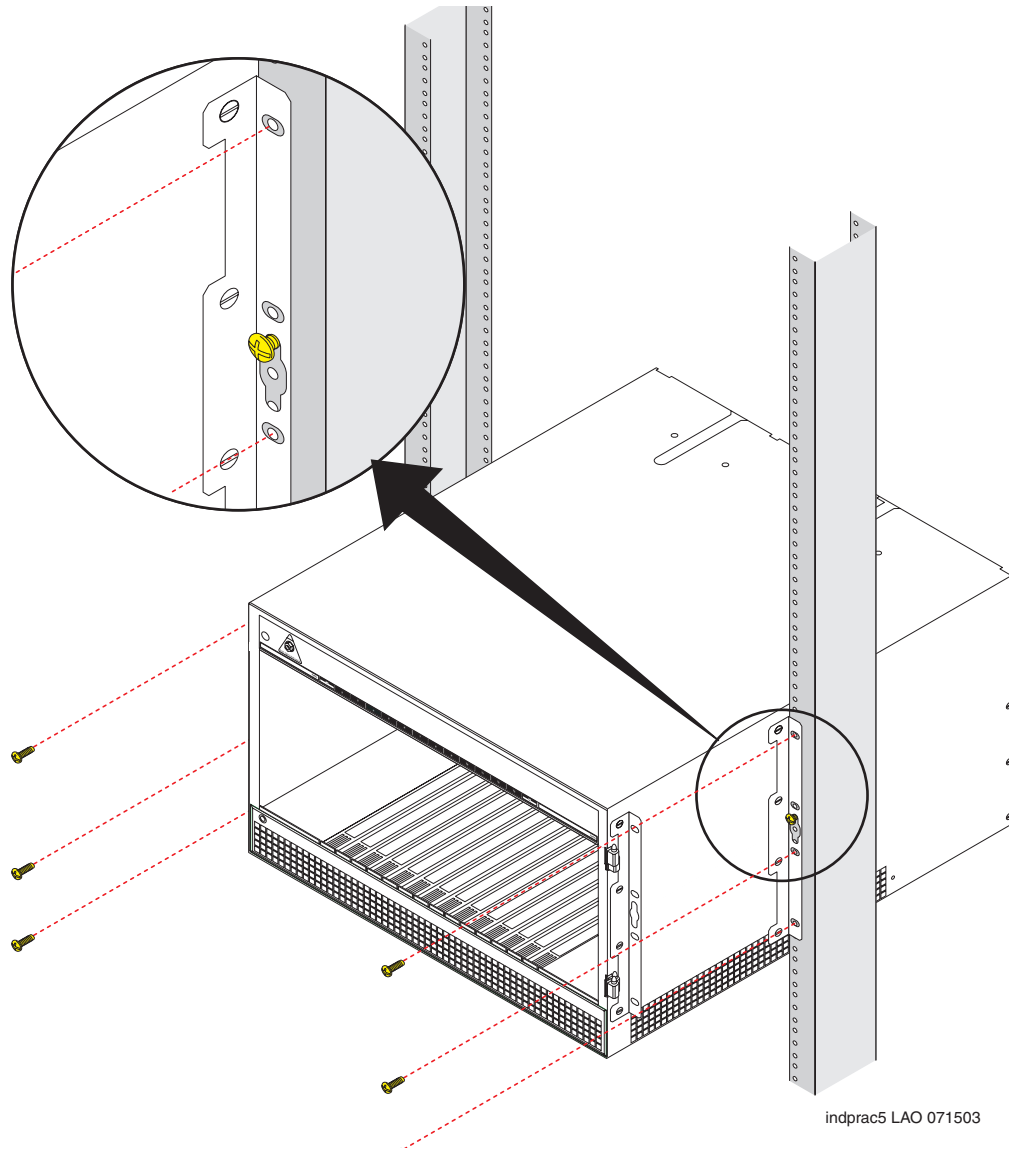

indprac5 LAO 071503

**⚠ DANGER:**

Use lifting precautions! An empty G650 Media Gateway weighs 35 pounds (16 kilograms).

5. Lift the empty G650 Media Gateway and slide the keyhole-shaped slots on the mounting brackets onto the two mounting screws.
6. Install and tighten the two top mounting screws.

7. Install and tighten the remaining screws ([Figure 6: Placement of the holes on the rack and the first mounting screws](#) on page 25).

**Note:**

Follow the same steps to install the G650 Media Gateway with mounting bracket in the middle position ([Figure 7: Mounting the media gateway](#) on page 26).

8. Set the ringer selection switch on each 655A power supply. For the position of the ringer switch, see [Figure 8: Fuse and ringer switch on the 655A power supply](#) on page 27.

You can set the switch for:

- 20 Hz—North American
- 25 Hz—European and international
- Off—No ringing output. Use this setting when an external ring generator, such as the TN2202 French ringing circuit pack, is provided.

---

**Figure 8: Fuse and ringer switch on the 655A power supply**

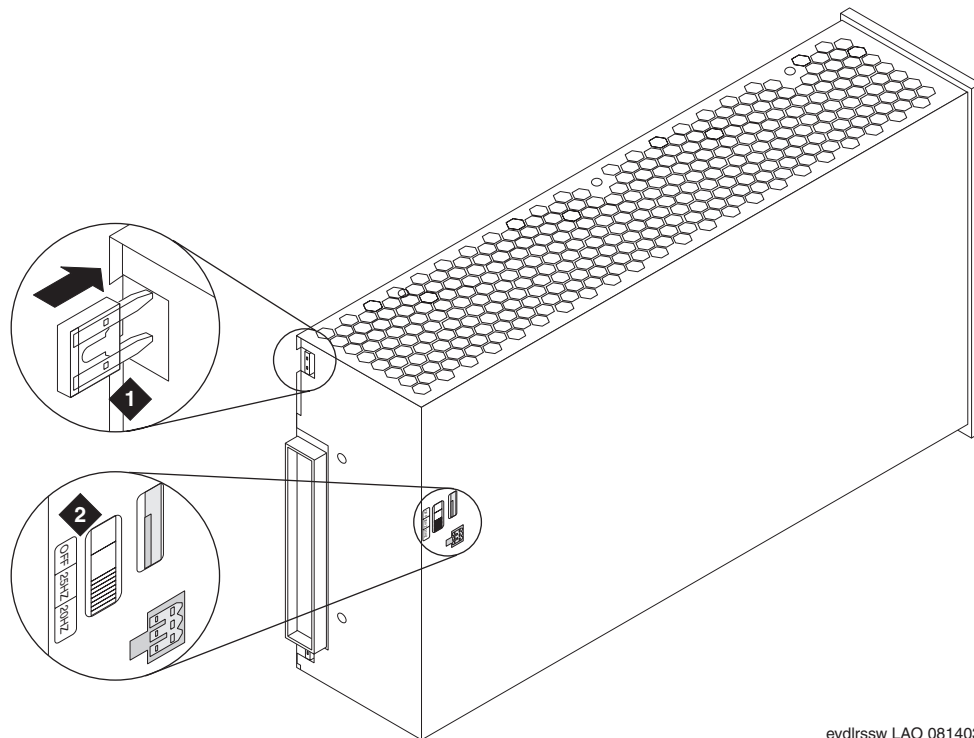

evdlrsw LAO 081403

**Figure notes:**

1. Fuse

2. Ringer switch

## Installing and cabling the G650 Media Gateway

### Note:

If you plug a power supply into a slot that did not previously contain a power supply, the power supply will self administer.

9. Reinstall the power supply.
10. Perform one of the following actions:
  - If you are installing one G650 Media Gateway, replace the fan assembly and tighten the seven screws. All knurled screws must be tightened securely so that the screws cannot be loosened without the use of a tool. Continue with [Installing the TN2312BP IPSI adapter](#) on page 29.
  - If you are installing multiple G650 Media Gateways, continue with [Mounting two to five G650 Media Gateways](#) on page 28.

---

## Power supply fuse

The fuse protects the DC input from reverse voltage on the -48 VDC input. If you apply reverse voltage to the G650 Media Gateway and the 655A power supply, the 655A fuse blows open to protect the 655A power supply from damage. The fuse is located on each end of the rear surface of the 655A power supply ([Figure 8: Fuse and ringer switch on the 655A power supply](#) on page 27). The DC input protection fuse and a spare fuse are located in the two fuse positions.

If the G650 Media Gateway does not operate on DC input only, inspect the fuse. Remove the 655A power supply from the G650 Media Gateway and inspect the protection fuse.

Avaya ships a spare fuse with the power supply.

---

## Mounting two to five G650 Media Gateways

### Note:

In a configuration that includes multiple G650 Media Gateways, put the G650s in the rack with no vertical space between the gateways. If the G650 Media Gateways are not mounted adjacent with their fronts in the same vertical plane, the TDM/LAN cable(s) cannot connect them.

When you mount more than one G650 Media Gateway in a rack, put:

1. A in the bottom of the rack
2. B directly above A
3. C directly above B
4. D directly above C
5. E directly above D

EMI gaskets provide electromagnetic interference to or from the TDM cable with the outside environment. You must install the EMI gaskets before you put cabinets B, C, D, or E in the rack.

To install the EMI gaskets:

1. Peel the paper backing from the gasket
2. Locate the unpainted outlined area on top of the G650 Media Gateway
3. With the gasket opening facing the rear of the rack, place the gasket on the:
  - a. Right top for G650 A and C
  - b. Left top for G650 B and D

After you put the last G650 in the rack:

1. Cable the rack (see [Cabling the G650 Media Gateways](#) on page 41).
2. Install the TN2312BP IPSI adapter (proceed to [Installing the TN2312BP IPSI adapter](#) on page 29).

---

## Installing the TN2312BP IPSI adapter

[Figure 9: G650 IPSI adapter](#) shows the TN2312BP IPSI adapter.

**Note:**

This adapter is used with both the TN2312BP IPSI and the TN8412AP SIPI circuit pack.

To install the TN2312BP IPSI adapter:

1. Install the TN2312BP IPSI adapter on the connector panel in position 1 for carrier A.
2. If you use duplicated IPSIs, connect another IPSI adapter in position 1 for carrier B.
3. To connect the G650 to the Ethernet, connect the CAT 5 Ethernet cable to the adapter.
4. If you want to use the external alarm function, attach a 9-pin external alarm cable to the TN2312BP IPSI adapter. For the unterminated end, see the job aid titled *Connector and Cable Diagrams (Pinout Charts)* (555-245-773).

---

**Figure 9: G650 IPSI adapter**

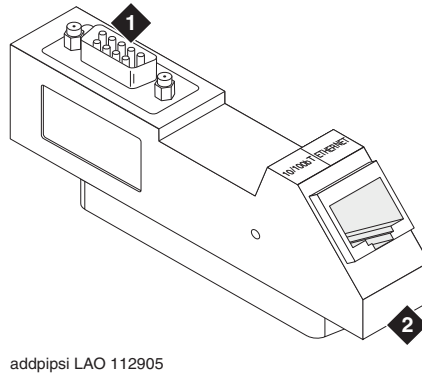

**Figure notes:**

**1. D9 connector**

**2. RJ45**

---

---

## Approved ground

The G650 Media Gateway relies on two ground connections. These connections are main plug and an earth contact and a permanent Supplementary Ground Conductor.

**⚠ WARNING:**

Installation in a restricted access location and secure access are required in Finland and Norway.

Because of unreliable earthing concerns in Finland and Norway, the G650 Media Gateway must be installed in a restricted access location (RAL). An RAL is an access that can be gained only by trained service personnel or customers who were instructed about the reasons for the restricted access and any safety precautions that must be taken. In these cases, you can gain access to the G650 Media Gateway by the use of a lock and key or other means of security.

If you have any questions about the safety conditions, contact your project manager. When you verify that the site is ready for installation, proceed with the installation.

For more information, see *Approved Grounds* (555-245-772).

---

## Connecting the G650 Media Gateway grounds and other grounds

Follow these additional grounding requirements:

- The approved ground wire must be a green / yellow, 10 AWG, copper, stranded wire.
- You must bond all approved grounds at the single-point ground to form a single grounding electrode system.

Connect the cable. [Figure 10: Grounding for a single G650 Media Gateway](#) on page 31 shows the connection for a single G650 Media Gateway. [Figure 11: Grounding for multiple G650 Media Gateways](#) on page 32 shows the connection for two or more G650 Media Gateways.

---

**Figure 10: Grounding for a single G650 Media Gateway**

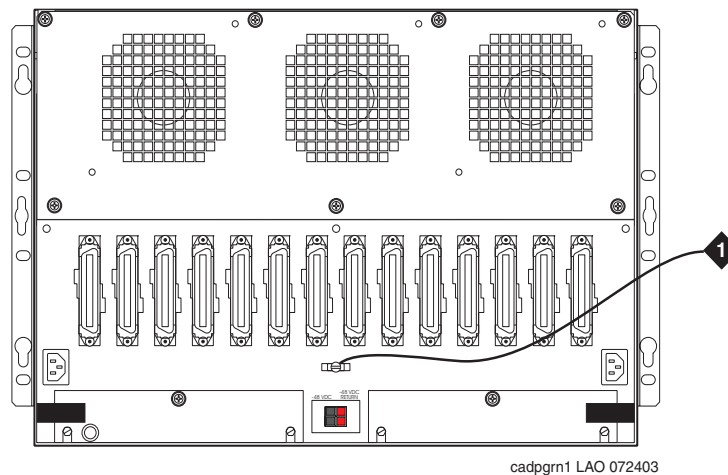

**Figure notes:**

1. 10 AWG (6 mm<sup>2</sup>) wire to an approved ground

**Figure 11: Grounding for multiple G650 Media Gateways**

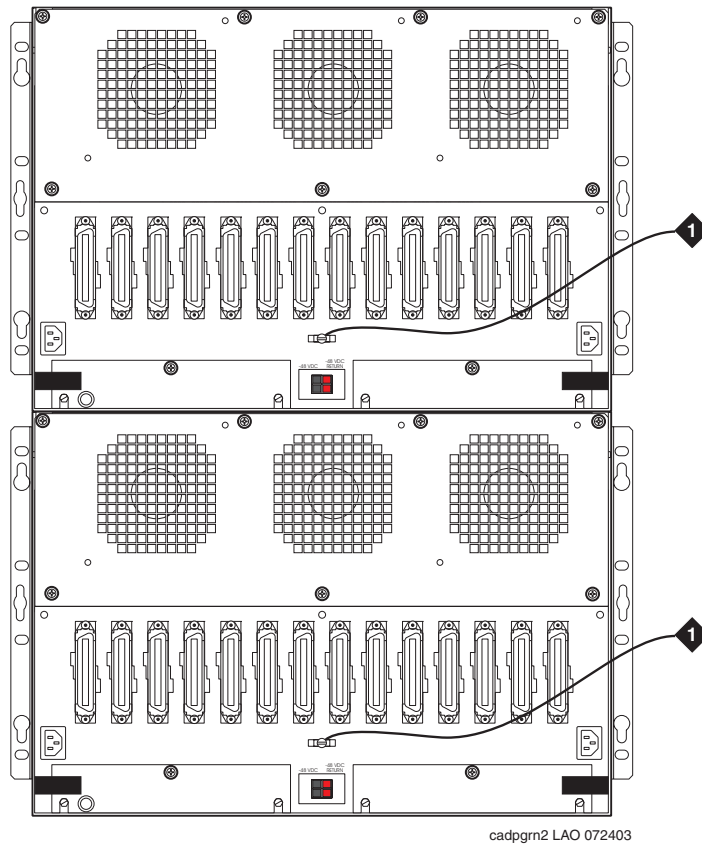

**Figure notes:**

1. 10 AWG (6 mm<sup>2</sup>) wire to an approved ground

---

## Connecting to AC power

### Chassis power source information for the G650 Media Gateway

Chassis style and power distribution unit:

- AC or DC power supply (Apparatus Code 655A)
- A 655A power supply is required in slot 0
- A 655A power supply is optional in slot 15

Power source options:

- Single-phase 120-VAC with neutral wire
- Single-phase 240-VAC with neutral wire
- -48 VDC

Power input receptacles:

- 120-VAC, 60-Hz NEMA 5-15R to IEC 60320 appliance inlet.
- 240-VAC, 50-Hz country selectable to IEC 60320 appliance inlet.
- When you install G650s in Japan, use country-specific receptacles for 100 VAC and 200 VAC, 50/60 Hz.
- When you install G650s in Mexico, use country specific receptacles for 127 VAC.

## Connecting the power cords

### **WARNING:**

You can connect the AC power cord to a properly rated power distribution unit, individual AC power receptacles, or to a UPS. Avaya recommends a rack-mounted UPS.

To connect the power cords:

1. Ensure that the circuit breakers at the AC load center are OFF.
2. Connect the G650 Media Gateway to a UPS or to an electrical outlet that is “nonswitched” or “always on” ([Figure 10: Grounding for a single G650 Media Gateway](#) on page 31 and [Figure 11: Grounding for multiple G650 Media Gateways](#) on page 32).

## Checking AC power

Each G650 Media Gateway uses at least one auto-ranging (90-VAC to 265-VAC) power supply:

- 47 to 63 HZ
- 500 W output
- 7.2 A (90 VAC) or 3.3 A (200 VAC)

## Required input current

[Table 1: G650 Media Gateway worst-case current levels](#) on page 34 shows the worst-case current levels for a fully loaded G650 Media Gateway. Each empty slot reduces the required input current by 1/4 A.

**Table 1: G650 Media Gateway worst-case current levels**

Input volts AC	Required Amps AC	Input volts DC	Required Amps DC
90	7.2	40	16.7
100	6.4	42	15.9
120	5.4	48	13.9
230	2.8	54	12.4
255	2.5	60	11.1
265	2.4		

The AC power source for each power supply installed in the G650 Media Gateway can be either:

- 1 phase of 120 VAC with neutral (100 VAC for Japan) with 15-amp circuit breaker
- 1 phase of 220 or 240 VAC (200 VAC for Japan) with 10-amp circuit breaker.

## Testing the AC outlet

 **WARNING:**

The following recommended test equipment, tests, and diagrams are intended only for North American installations at 110 VAC to 125 VAC. For installations in other regions, have a licensed electrician verify the ground and voltages.

 **WARNING:**

If the AC outlet tests indicate that the power requirements are not met, advise the customer to contact a licensed electrician. *Do not install the system until all requirements are met.*

## Using an ideal 61-035 Circuit Tester (or equivalent) to verify ground

To use an ideal 61-035 Circuit Tester to verify ground:

1. Plug the circuit tester into the outlet that you want to test.

If the circuit is properly grounded, the yellow and white lights on the tester illuminate.

2. Unplug the tester.

**⚠ WARNING:**

If the tester indicates any type of ground fault, advise the customer to contact a licensed electrician. *Do not install the system.*

## Using a VOM in the US and countries that use 110-VAC to 125-VAC power to verify voltage

**⚠ WARNING:**

Hazardous voltages are present during this test. Follow all instructions carefully when you work with AC power line voltages.

**Note:**

The following example is for North American voltages (110 VAC to 125 VAC). Use the appropriate voltages for local power.

To use a Volt-Ohm-Multimeter (VOM) to verify voltage:

1. Ensure that the VOM is set to read Volts AC.
2. Set the VOM to the lowest scale on which you can read 130 VAC.
3. Measure the AC voltages in the following order:

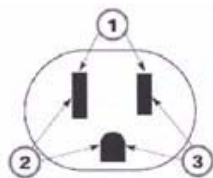

1. Phase to neutral must be 110 VAC to 125 VAC.
2. Neutral to ground must be less than 1 VAC.
3. Phase to ground must be 110 VAC to 125 VAC.

If the voltage readings do not measure the values given, the AC outlet is improperly wired. Advise the customer to have a licensed electrician correct the problem. *Do not install the system.*

You are now ready to turn on the system.

### Plugging in AC power

Once you verify that the ground and the voltages are correct for the installation, plug in the AC power.

Before you turn on the system, check the AC power in the equipment room. Use a KS-20599 digital voltmeter (DVM) or an equivalent meter.

To check AC power:

1. Verify that the voltage meter reads either 90 VAC to 132 VAC or 180 VAC to 264 VAC. Measure the AC voltage between the hot side and neutral side of the receptacle. Advise the customer to have a qualified electrician correct any problems before proceeding to Step 2.
2. Verify that the voltage meter reads 0 VAC. Measure the voltage between the neutral side and ground side of the receptacle. Advise the customer to have a qualified electrician correct any problems before proceeding to Step 3.
3. Set the AC main circuit breakers to OFF when you finish checking the AC power.

---

### Connecting to DC power

#### DC power layout

[Figure 12: Typical DC power layout for a G650](#) on page 38 shows a typical DC power layout for a G650 Media Gateway.

Each G650 Media Gateway can be equipped with a maximum of two 655A power supplies. One power supply is always provided in slot 0, and a redundant unit can be provided in slot 15. DC power is supplied by a DC feed cable to one connector on the backplane of the G650 Media Gateway. The power is then bussed to each power supply slot. AC current and DC current can be supplied to the 655A power supplies at the same time. When both AC current and DC current are present, the 655A uses AC first. The 655A power supply then changes to DC current without any interruption in service if the AC current fails.

Each G650 Media Gateway, with either a single power supply or redundant power supply, draws a maximum of 17 A of DC current.

## Required input current

[Table 2: G650 Media Gateway worst-case current levels](#) shows the worst-case current levels for a fully loaded G650 Media Gateway. Each empty slot reduces the required input current by 1/4 A.

**Table 2: G650 Media Gateway worst-case current levels**

VA	VDC	ADC	Efficiency	PF	BTU/HR	Watts	
667	40	16.7	75.4	0.994	2277	667.1328	Minimum DC plant voltage
667	42	15.9	75.4	0.994	2277	667.1328	Low Voltage Disconnect (LVD) voltage
667	48	13.9	75.4	0.994	2277	667.1328	Typical plant voltage
667	54	12.4	75.4	0.994	2277	667.1328	Typical plant float voltage
667	60	11.1	75.4	0.994	2277	667.1328	Maximum plant voltage

Before you connect the DC feed cable to the DC power source of the G650 Media Gateway, check the DC power source. Use a KS-20599 digital voltmeter or an equivalent meter.

To check DC power:

1. Verify that the meter reads between -42.5 VDC and -54.2 VDC across the -48 VDC and -48-V return distribution leads from the DC source.
2. Verify that the meter reads 0 V between the -48-V return lead of the DC power source and the approved ground.
3. If either step 1 or step 2 fails the verification, *do not continue with step 4*. Advise the customer to have a licensed electrician correct the problem.
4. Connect the DC feed cable for each G650 Media Gateway to the DC power source. For more information, see [Figure 10: Grounding for a single G650 Media Gateway](#) on page 31 and [Figure 11: Grounding for multiple G650 Media Gateways](#) on page 32.
  - a. Connect the red insulated 10-AWG lead to the -48-V return (positive) source.
  - b. Connect the black insulated 10-AWG lead to the -48-V DC (negative) source.

Figure 12: Typical DC power layout for a G650

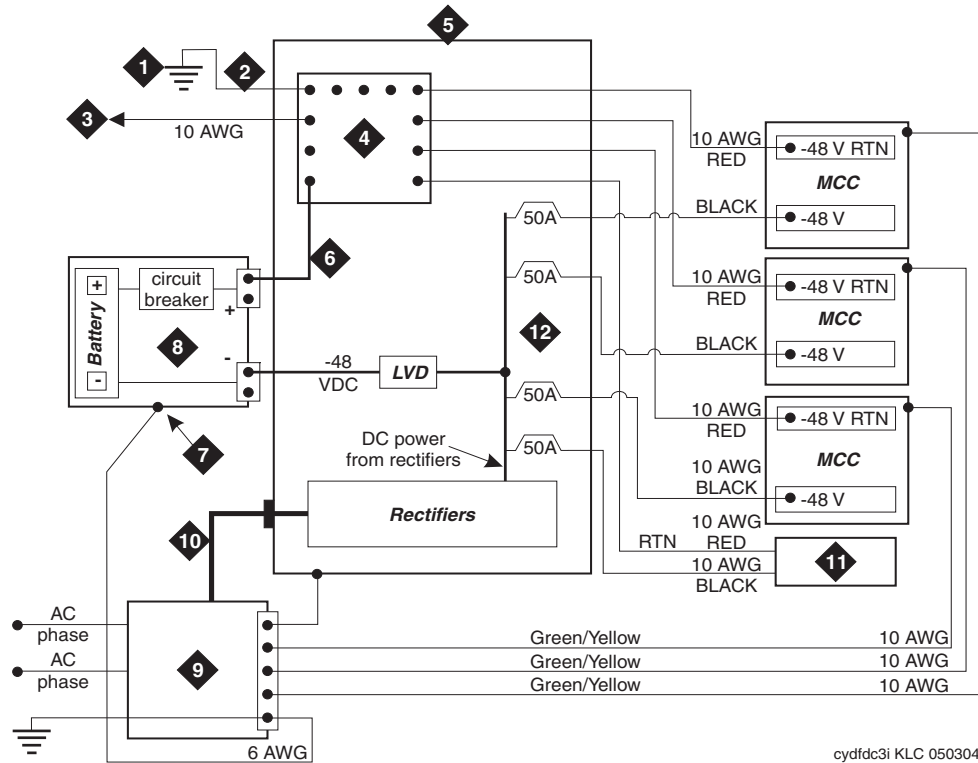

Figure notes:

- |  |  |
|--|--|
| <ol style="list-style-type: none"> <li>1. Approved ground</li> <li>2. 1 AWG ground wire</li> <li>3. CBC ground terminal bar at the MDF (if used)</li> <li>4. System single-point ground discharge bar</li> <li>5. DC power cabinet J58890R or new DC system</li> </ol> | <ol style="list-style-type: none"> <li>6. Ground wire for battery (+)</li> <li>7. Battery frame ground</li> <li>8. DC battery cabinet</li> <li>9. Main AC supply (AC mains)</li> <li>10. AC to DC power cabinet</li> <li>11. To next DC-powered media gateway</li> <li>12. DC load circuit breakers</li> </ol> |
|--|--|

---

## Using an uninterruptible power supply

An uninterruptible power supply (UPS) can be used for power protection and holdover time on loss of AC power. Therefore, UPS increases the availability of G650 Media Gateway. Select a UPS that meets the power capacity and holdover time that is required for your site. See <http://www.avayaups.com/avaya/default.asp> for sizing and holdover information. The UPS also provides surge protection for the G650 Media Gateway.

 **CAUTION:**

The major alarm contacts connect *only* to a UPS that can indicate that the UPS is on backup power. For most non-Avaya UPSs, do not use the major external device leads.

## Installing a UPS

To install a UPS:

1. Connect the UPS to an electrical outlet that can handle the power requirements of the G650 Media Gateway:
  - a. 100 VAC, 7.2 A
  - b. 120 VAC, 6.4 A
  - c. 200 VAC, 3.3 A
  - d. 220 to 240 VAC, 2.8 A

For more information, see [Table 1: G650 Media Gateway worst-case current levels](#) on page 34.

2. Ensure that the G650 Media Gateway is connected to an electrical outlet on the UPS that is “nonswitched” or “always on.”
3. Connect and administer the Avaya UPS. Note that customers must connect and administer any non-Avaya UPS.

The holdover time for each power outage is part of the configuration of the UPS to support the G650 Media Gateway string of carriers. The UPS issues a major alarm for the following conditions:

- Loss of AC. The advertised holdover time is available.
- UPS on bypass. The UPS failed and must be serviced.
- Low battery warning is issued at approximately 5 minutes before shutdown.

**Note:**

If the UPS is wired as recommended, the Avaya UPS issues a shutdown warning 5 minutes prior to the end of life of the battery. A UPS handles any subsequent power outage based on the total battery capacity of the UPS.

## G650 Media Gateway power switch

**⚠ DANGER:**

The latch on the power supply does not remove power from the G650 Media Gateway. For more information, see [Figure 13: Power supply for the G650 Media Gateway](#). To remove the AC power from the 655A, pull the AC power cord from the back of the G650 Media Gateway. If the system contains redundant power supplies, pull both AC power cords from the back of the G650 Media Gateway. To remove DC power, first locate and turn the external DC circuit breaker to the off position. Then disconnect the DC power feed at the back of the G650 Media Gateway.

**Figure 13: Power supply for the G650 Media Gateway**

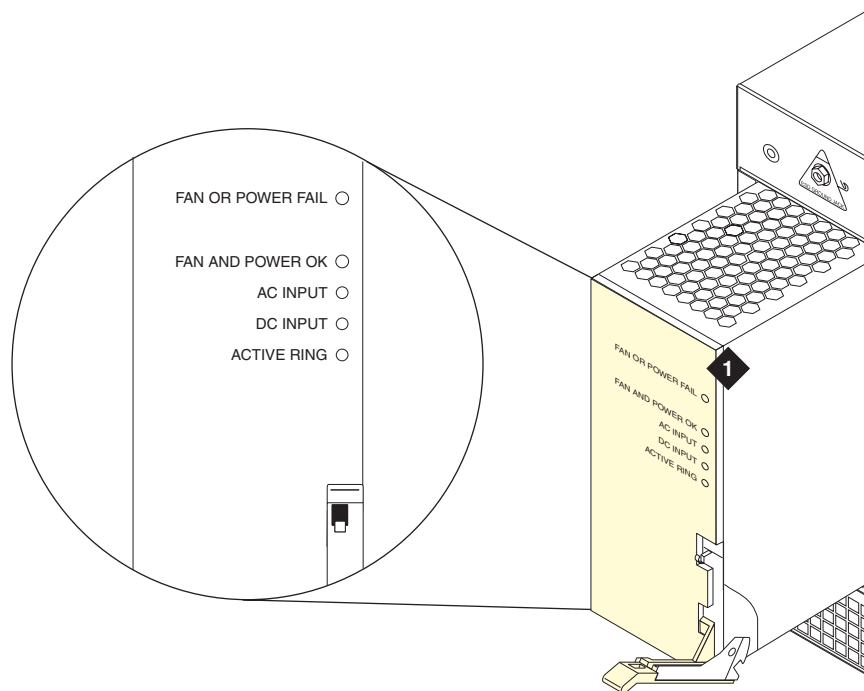

evc

**Figure notes:**

1. Power supply

---

## Cabling the G650 Media Gateways

After you mount the G650 Media Gateways in the rack, connect:

- The TDM/LAN cables between them
- CAT5 cables to the appropriate slots on the back of the media gateways

You can mount and cable up to five media gateways in a rack. The media gateway on the bottom is referred to as media gateway A. The other media gateways are referred to as media gateways B, C, D, and E, from the bottom to the top media gateway in the rack.

**Note:**

The TDM/LAN Bus cable is snug. If you skip a rung in the rack when mounting additional G650 Media Gateways, the cable will not reach. The G650 Media Gateway and the TDM/LAN Bus cable were designed to stack five gateways.

Perform the following tasks to cable the G650 Media Gateway:

- [Cabling two media gateways](#) on page 42
- [Cabling the third media gateway](#) on page 43
- [Cabling the fourth media gateway](#) on page 43
- [Cabling the fifth media gateway](#) on page 44
- [Installing circuit packs in the G650 Media Gateway](#) on page 50

When you cable the media gateways together, refer to the *G650 TDM/LAN Cable Installation* diagram included with the shipment or the diagrams at the end of these procedures:

- [Figure 14: G650 TDM/LAN cable installation \(part 1\)](#) on page 45
- [Figure 15: G650 TDM/LAN cable installation \(part 2\)](#) on page 46
- [Figure 16: G650 TDM/LAN cable installation \(part 3\)](#) on page 47
- [Figure 17: G650 TDM/LAN cable installation \(part 4\)](#) on page 48
- [Figure 18: G650 TDM/LAN cable installation \(part 5\)](#) on page 49

## Cabling two media gateways

To cable two media gateways:

1. If the fan assemblies are not already removed, remove the fan assemblies from media gateways A and B.
2. Remove the right TDM/LAN bus terminator from media gateway A, and install the bus terminator at the left end of the TDM/LAN bus on media gateway B.

 **WARNING:**

Ensure that you install the TDM/LAN bus terminators so that the arrow on the back points upward.

3. Loosen the nuts on the posts of the plate that covers the bottom right TDM/LAN cable routing slot of media gateway B. Remove the plate.
4. Remove the right slot cover on the top of media gateway A and the lower-right slot of media gateway B to open the slots.
5. Pull open the EMI gasket, and pass the TDM/LAN bus cable through the routing slots in both media gateways. Push the free end of the EMI gasket back in place. Ensure that the the open corner of the gasket faces the rear of the media gateway. Once installed, the top media gateway rests on and compresses the gasket.
6. In media gateway A, install the lower connector of the TDM/LAN bus cable on the right end of the TDM/LAN bus.

 **WARNING:**

Ensure that the arrows on the back of the cable terminators point upward.

7. In media gateway B, install the upper connector of the TDM/LAN bus cable on the right end of the TDM/LAN bus.

 **WARNING:**

Make sure the TDM/LAN bus cable is installed on the right-hand side, connecting gateway A to B. It should be on the right-hand side of both gateways. This placement is critical to ensure proper operation of the duplicated IPSI boards.

8. Flip over the routing slot plates and reinstall both plates. Once you reinstall the plates, the ends of the routing slots are covered.
9. Perform one of the following actions:
  - If the system includes only two media gateways, reinstall the fan assemblies and tighten the seven screws. Tighten all knurled screws securely so that the screws cannot be loosened without the use of a tool.
  - If the system includes more than two media gateways, continue with [Cabling the third media gateway](#) on page 43.

---

## Cabling the third media gateway

To cable the third media gateway:

1. If the fan assemblies are not already removed, remove the fan assemblies from media gateways B and C.
2. Remove the left TDM/LAN bus terminator from media gateway B, and install the bus terminator at the right end of the TDM/LAN bus in media gateway C.
3. Remove the nuts on the posts of the plates covering:
  - the bottom left TDM/LAN cable routing slot of media gateway C and
  - the top left TDM/LAN cable routing slot of media gateway B.
4. Remove the left slot cover on top of media gateway B and the lower-left slot cover of media gateway C to open the slots.
5. Pull open the EMI gasket, and pass the TDM/LAN bus cable through the routing slots in both media gateways. Push the free end of the EMI gasket back in place.
6. In media gateway B, install the lower connector of the TDM/LAN bus cable on the left end of the TDM/LAN bus. Ensure that the arrows on the back of the cable terminators point upward.
7. In media gateway C, install the upper connector of the TDM/LAN bus cable on the left end of the TDM/LAN bus.
8. Flip over the routing slot plates and reinstall both plates. Once you reinstall the plates, the ends of the routing slots are covered.
9. Perform one of the following actions:
  - If the system includes only three media gateways, reinstall the fan assemblies and tighten the seven screws. Tighten all knurled screws securely so that the screws cannot be loosened without the use of a tool.
  - If the system includes more than three media gateways, continue with [Cabling the fourth media gateway](#) on page 43.

---

## Cabling the fourth media gateway

To cable the fourth media gateway:

1. If the fan assemblies are not already removed, remove the fan assemblies from media gateways C and D.
2. Remove the right TDM/LAN bus terminator from media gateway C, and install the bus terminator at the left end of the TDM/LAN bus in media gateway D.

## Installing and cabling the G650 Media Gateway

3. Remove the nuts on the posts of the plates covering the bottom right TDM/LAN cable routing slot of media gateway D and the top right TDM/LAN cable routing slot of media gateway C.
4. Remove the left slot cover on top of media gateway C and the lower-left slot cover of media gateway D to open the slots.
5. Pull open the EMI gasket, and pass the TDM/LAN bus cable through the routing slots in both media gateways. Push the free end of the EMI gasket back in place.
6. In media gateway C, install the lower connector of the TDM/LAN bus cable on the right end of the TDM/LAN bus. Ensure that the arrows on the back of the cable terminators point upward.
7. In media gateway D, install the upper connector of the TDM/LAN bus cable on the right end of the TDM/LAN bus.
8. Flip over the routing slot plates and reinstall both plates. Once you reinstall the plates, the ends of the routing slots are covered.
9. Perform one of the following actions:
  - If the system includes only four media gateways, reinstall the fan assemblies and tighten the seven screws. Tighten all knurled screws securely so that the screws cannot be loosened without the use of a tool.
  - If the system includes more than four media gateways, continue with [Cabling the fifth media gateway](#) on page 44.

---

## Cabling the fifth media gateway

To cable the fifth media gateway:

1. If the fan assemblies are not already removed, remove the fan assemblies from media gateways D and E.
2. Remove the right TDM/LAN bus terminator from media gateway D, and install the bus terminator at the left end of the TDM/LAN bus in media gateway E.
3. Remove the nuts on the posts of the plates covering the bottom right TDM/LAN cable routing slot of media gateway E and the top right TDM/LAN cable routing slot of media gateway D.
4. Remove the left slot cover on top of media gateway D and the lower-left slot cover of media gateway E to open the slots.
5. Pull open the EMI gasket, and pass the TDM/LAN bus cable through the routing slots in both media gateways. Push the free end of the EMI gasket back in place.
6. In media gateway D, install the lower connector of the TDM/LAN bus cable on the right end of the TDM/LAN bus. Ensure that the arrows on the back of the cable terminators point upward.

7. In media gateway E, install the upper connector of the TDM/LAN bus cable on the right end of the TDM/LAN bus in media gateway E.
8. Flip over the routing slot plates and reinstall both plates. Once you reinstall the plates, the ends of the routing slots are covered.
9. Reinstall the fan assemblies and tighten the seven screws on each media gateway. Tighten all knurled screws securely so that the screws cannot be loosened without the use of a tool.

**Figure 14: G650 TDM/LAN cable installation (part 1)**

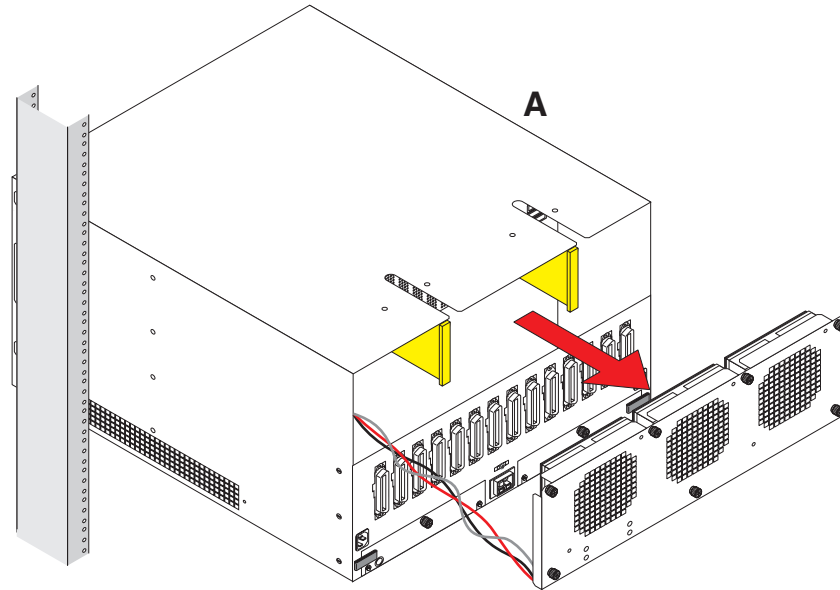

h3dptdm1 LAO 111505

---

**Figure 15: G650 TDM/LAN cable installation (part 2)**

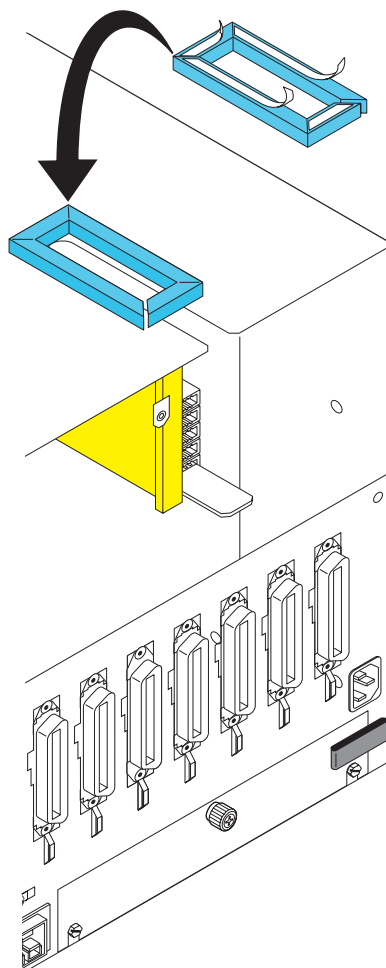

h3dptdm2 LAO 111505

Figure 16: G650 TDM/LAN cable installation (part 3)

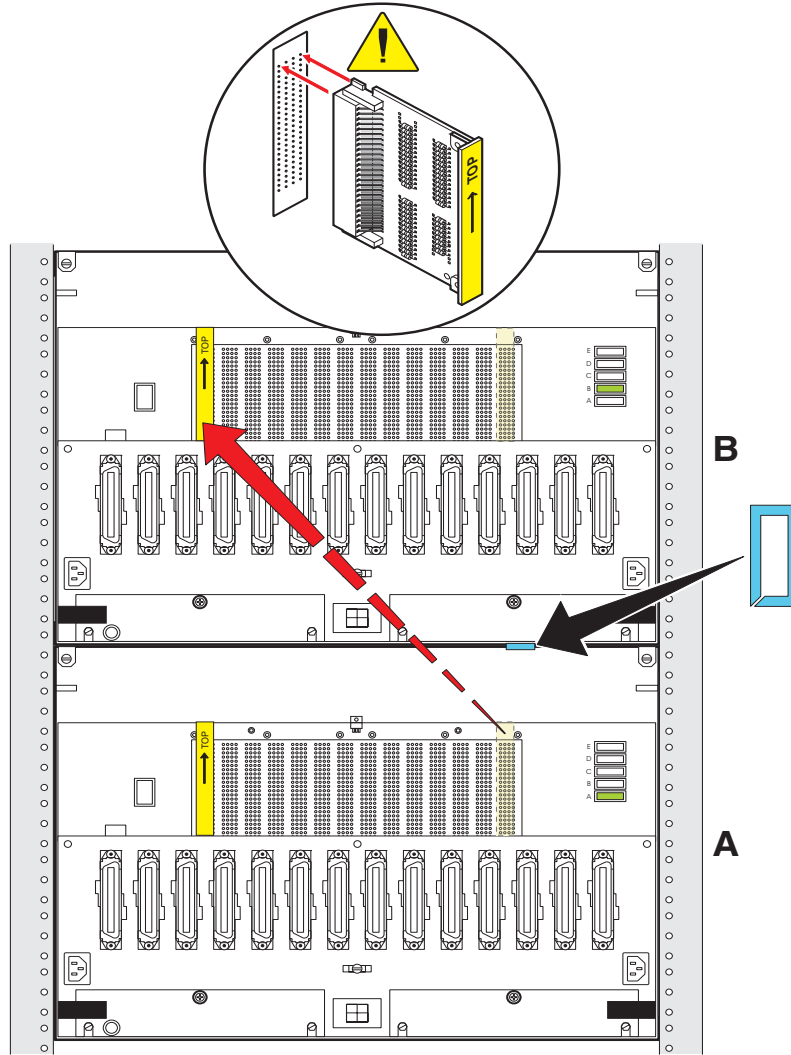

h3dptdm3 LAO 111505

Figure 17: G650 TDM/LAN cable installation (part 4)

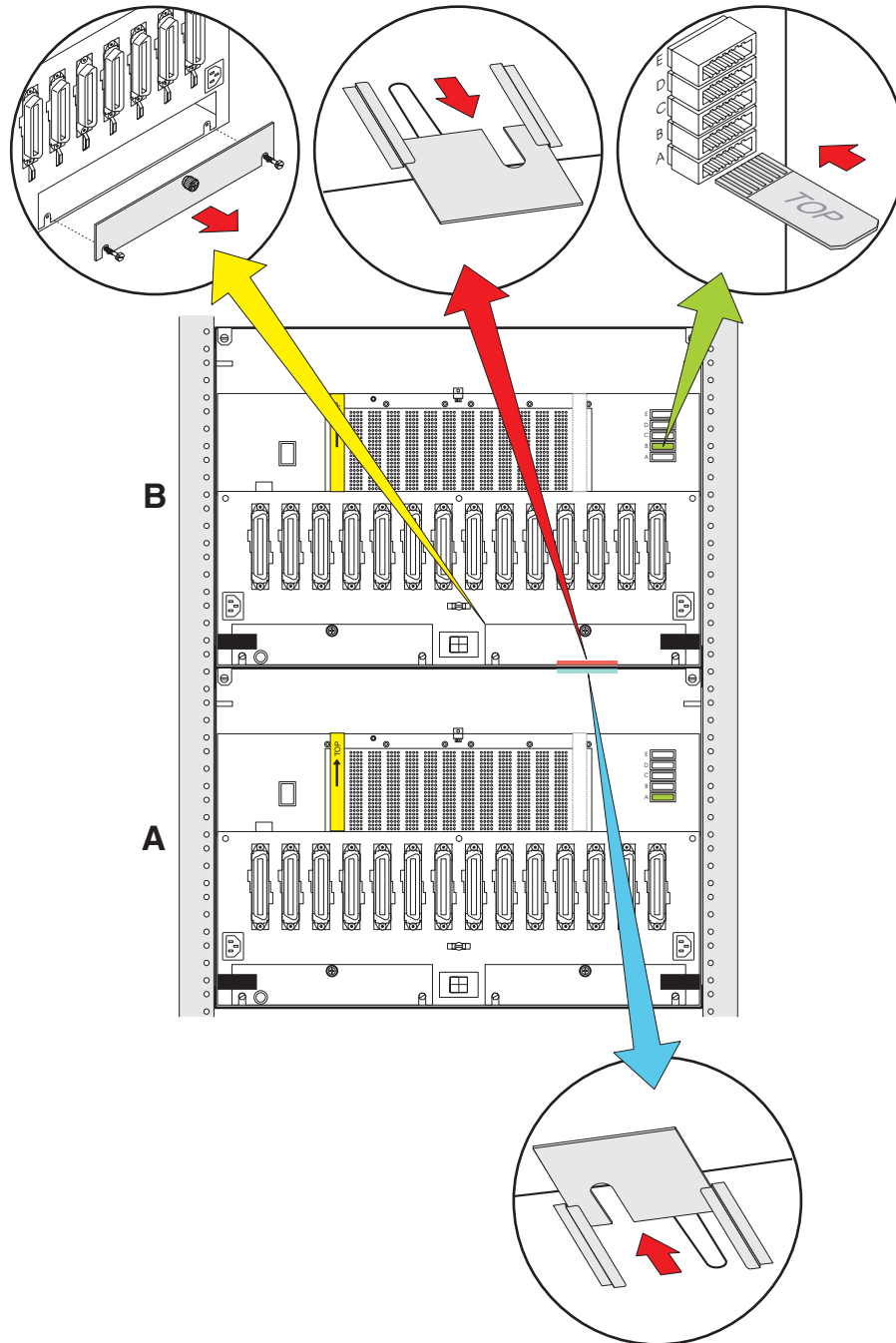

h3dptdm4 LAO 111505

Figure 18: G650 TDM/LAN cable installation (part 5)

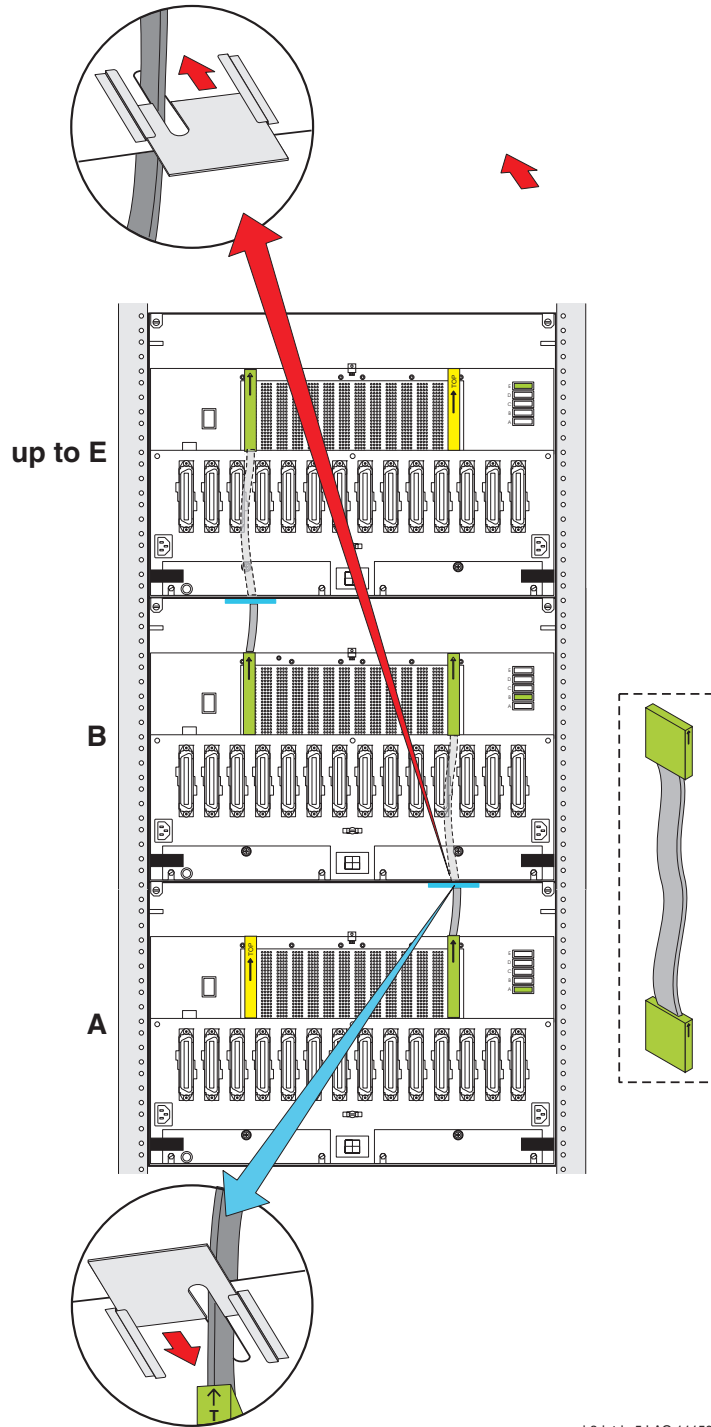

h3dptdm5 LAO 111505

## Installing circuit packs in the G650 Media Gateway

### CAUTION:

When handling circuit packs or any components of an G650 Media Gateway, always wear an authorized wrist ground strap. Connect the strap to the ground connector provided on the media gateway.

To install circuit packs:

1. Load all port circuit packs. See [Table 3: Circuit pack placement in the G650 Media Gateway](#) for the recommended circuit pack layouts. Slots in the G650 Media Gateway are numbered from left to right beginning with slot 0 ([Figure 19: Front view of a G650 Media Gateway](#) on page 51).

**Table 3: Circuit pack placement in the G650 Media Gateway**

Circuit pack name	Required or optional	Slot number	Notes
655A power supply	Required	0	Required
Redundant 655A power supply	Optional	15	If present, must be in slot 15.
TN2312BP IPSI or TN8412AP SIPI	Required	A01	Required
Second TN2312BP IPSI	Optional	B01	If present, must be in slot B01.
TN750, TN750B, TN750C Voice Announcement	Optional	Any slot	—
TN797	Optional	Any slot	—
TN799DP (or greater suffix) C-LAN	Optional	2	Recommended
TN2302 media processor	Optional	14	Recommended
TN2602AP IP media resource 320	Required	Any slot	Bearer duplication requires two 2602AP circuit packs in the same subnet.
TN771 maintenance/test board	One per customer location	Any slot	—

1 of 2

Table 3: Circuit pack placement in the G650 Media Gateway (continued)

Circuit pack name	Required or optional	Slot number	Notes
TN791 Analog line 16 port	Optional	Any slot	—
Port circuit packs	—	Slots on the left	Recommended
Trunk circuit packs	—	Slots on the right	Recommended

---

**2 of 2**

Figure 19: Front view of a G650 Media Gateway

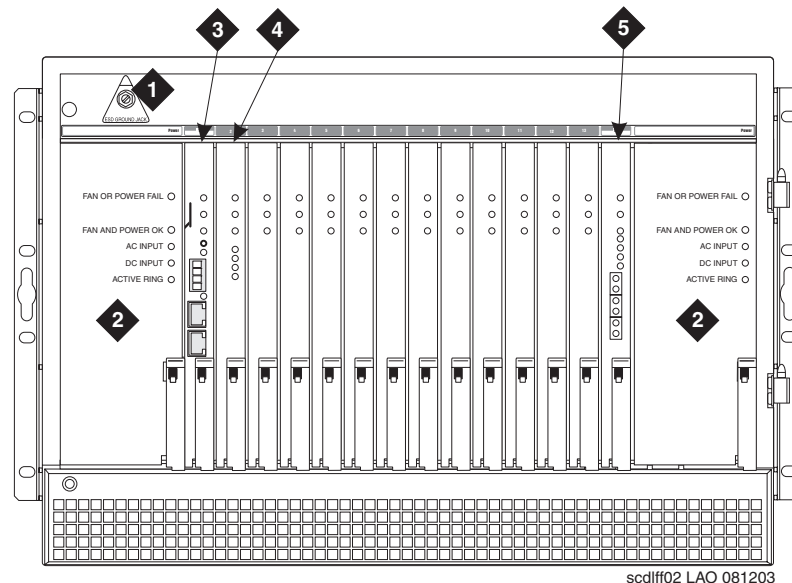

## Figure notes:

- |   |                              |
|---|------------------------------|
| 1. ESD ground jack  | 4. TN799DP C-LAN             |
| 2. 655A power supply  | 5. TN2302 IP Media Processor |
| 3. TN2312BP IPSI (in carrier A or B only) or TN8412AP SIPI circuit pack (in carrier A only) |                              |

2. Install the TN2312BP IPSI adapter ([Figure 20: G650 Media Gateway IPSI adapter](#) on page 52) on the connector panel in slot 1 for carrier A. If you are using duplicated IPSIs, connect another IPSI adapter in position 1 for carrier B. Connect the CAT 5 Ethernet cable to the adapter to connect the G650 Media Gateway to the Ethernet. If you want to use the external alarm function, attach an external alarm cable to the IPSI adapter.

---

**Figure 20: G650 Media Gateway IPSI adapter**

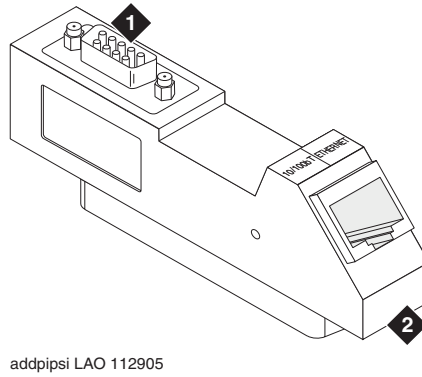

**Figure notes:**

**1. D9 connector**

**2. RJ45**

- 
3. If a circuit pack was installed in the G650 Media Gateway, install a circuit pack amphenol connector onto the backplane that corresponds to the location of the circuit pack.
    - a. At the corresponding location on the backplane, slide the cable connector into the retainer.
    - b. Attach the cable connector to the circuit pack amphenol connector and snap the retainer to secure the circuit pack amphenol connector in place.

## Chapter 3: Connecting to the customer's network

Servers and many other components connect directly to the customer's network. The following sections provide information for various IP components.

- [TN799DP Control LAN](#) on page 53
- [TN2302AP IP Media Processor](#) on page 53
- [TN801B MAP-D LAN Gateway](#) on page 55
- [TN2501AP Voice Announcement over LAN \(VAL\)](#) on page 55

---

### TN799DP Control LAN

The TN799DP Control-LAN (C-LAN) circuit pack serves multiple purposes:

- A connection for the signaling (telephone) network to the customer's data network for IP telephones.
- A source board for downloading firmware to circuit packs having the "P" designation.
- An IP interface for adjuncts such as Intuity Audix.
- An IP interface for DCS connection with another Avaya configuration.

For general information, see the *Hardware Description and Reference for Avaya Communication Manager (555-245-207)*.

For information on installing a TN799DP C-LAN circuit pack, see "TN799DP Control C-LAN" in *Adding New Hardware for Avaya Servers and Gateways (03-300684)*.

---

### TN2302AP IP Media Processor

The TN2302AP IP Media Processor circuit pack provides an interface between a customer's IP network and Avaya media gateways. This interface transports voice and FAX between the media gateways and IP devices, such as H.323 V2 compliant endpoints, and other Avaya telephone systems. Each TN2302AP can support between 32 and 64 voice channels, depending on the codecs used.

**Note:**

The P board suffix designation means the circuit pack is firmware-downloadable. For the download procedures, see the information at <http://www.avaya.com/support/>. Click **Online Services > Download Software**.

For more information, see the *Hardware Description and Reference for Avaya Communication Manager* (555-245-207).

For information on installing a TN2302AP IP Media Processor circuit pack, see "TN2302AP IP Media Processor" in *Adding New Hardware for Avaya Servers and Gateways* (03-300684).

---

## TN2602AP IP Media Resource 320

The TN2602AP IP Media Resource 320 provides high-capacity voice over Internet protocol (VoIP) audio access to the switch for local stations and outside trunks. The IP Media Resource 320 provides audio processing for the following types of calls:

- TDM-to-IP and IP-to-TDM
- IP-to-IP

You can install up to two TN2602AP circuit packs in a single port network for load balancing. The TN2602AP circuit pack is also compatible with and can share load balancing with the TN2302 IP Media Processor circuit pack. Actual capacity can be affected by a variety of factors, including the codec used for a call and fax support.

Two TN2602AP circuit packs may be installed in a single port network (PN) for bearer duplication. In this configuration, one TN2602AP is an active IP media processor and one is a standby IP media processor. If the active media processor fails, active calls failover to the standby media processor and remain active. This duplication prevents active calls in progress from being dropped in case of failure. The interchange between duplicated circuit packs affects only the PN in which the circuit packs reside.

For information on installing a TN2602 IP Media Resource circuit pack, see "TN2602 IP Media Resource 320" in *Adding New Hardware for Avaya Servers and Gateways* (03-300684).

---

## TN801B MAP-D LAN Gateway

The TN801 LAN gateway circuit pack is part of the Multi-Application Platform DEFINITY (MAPD). It allows direct integration of a PC-based application into the configuration. The TN801 LAN gateway circuit pack works as the interface for solutions such as CTI, CallVisor and PC/LAN.

For installation and administration information, see the *DEFINITY ECS CallVisor ASA/DEFINITY LAN Gateway over MAPD: Installation, Administration, and Maintenance* (555-230-114).

---

## TN2501AP Voice Announcement over LAN (VAL)

The TN2501AP Voice Announcement Over LAN (VAL) circuit pack is an integrated announcement circuit pack that:

- offers up to 1 hour of announcement storage capacity
- requires shorter backup and restore times
- is firmware downloadable
- plays announcements over the TDM bus
- has 33 ports, including:
  - one dedicated telephone port for recording and playing back announcements (port number 1)
  - one ethernet port (port number 33)
  - 31 playback ports (ports 2–32)
- 10/100 Mb Ethernet interface, allowing announcement and firmware file portability over your LAN (FTP server functions)
- supports \*.wav announcement files

## Important file specifications

Voice Announcement over LAN (VAL) requires that announcement files are in the following \*.wav formats:

- CCITT A-Law or CCITT  $\mu$ -Law (mu-Law) companding format (do not use PCM)
- 8-kHz sample rate
- 8-bit resolution (bits per sample)
- Mono (channels = 1)

You must convert other wave (\*.wav) file formats to those listed. Telephone access creates the correct file formats.

---

## Caveats

Remember the following points when using the TN2501AP integrated announcement circuit pack for the first time:

- Despite the feature name, announcements are not played over the LAN but can be transferred to and from the TN2501AP Voice Over LAN (VAL) circuit pack.
- You cannot save or restore announcements to a TN2501AP circuit pack to or from:
  - a TN750C circuit pack
  - flashcards
  - tape
  - magneto optical disks.

**Note:**

The P board suffix designation means the circuit pack is firmware-downloadable. For the download procedures, see the information at <http://www.avaya.com/support/>. Click **Online Services > Download Software**.

For more information, see the *Hardware Description and Reference for Avaya Communication Manager* (555-245-207).

For information on installing a TN2501AP VAL circuit pack, see "TN2501AP Voice announcement over LAN (VAL)" in *Adding New Hardware for Avaya Servers and Gateways* (03-300684).

# Chapter 4: Testing the complete configuration

This section provides tests for the complete configuration, including the control network, signaling network, telephones, and consoles.

This section provides tests to:

- Review the status of the configuration
- Test the duplication link to the servers (S8700-series only)
- Test the IP server interfaces, expansion interfaces, and time-division multiplexing (TDM) buses in the port networks (PNs)
- Test the telephones and other equipment

For information about the LED status indicators for the Avaya Ethernet switches, uninterruptible power supplies (UPSs), and circuit packs, see [LED indicators](#) on page 66.

**Note:**

Cabinet and slot usually indicate circuit pack positions. Port can also indicate position. The term “cabinet” refers to five G650 Media Gateways that are TDM-cabled together in a rack to make up one PN. A port network is defined as a group of media gateways that are connected together with one TDM bus.

Perform the following tasks to test the configuration:

 **CAUTION:**

To prevent unnecessary trouble tickets, do not enable the alarms, Alarm Origination feature, until you complete all installation and administration procedures.

- [Testing port network equipment](#) on page 58
- [Checking PN status for each media gateway](#) on page 58
- [Checking circuit pack configuration](#) on page 58
- [Testing the TN2312BP IPSI circuit pack](#) on page 59
- [Testing bearer duplication with the TN2602AP circuit pack](#) on page 59
- [Testing the TDM bus for each PN](#) on page 60
- [Testing telephones and other equipment](#) on page 61

## Testing port network equipment

The tests in this section verify that the TDM cables and terminators work. If you see a **FAIL** result code, check these cables. If problems persist, see the maintenance book for your configuration.

---

## Checking PN status for each media gateway

The PN status can suggest problem areas. Tests that are described later in this section provide more specific diagnostic information.

To check the PN status for each media gateway:

1. Type `status port-network number <1-64>` and press **Enter**.
2. Verify these service states:

Field	Service State
TDM Bus A	in
TDM Bus B	in
Tone/Clock	in
PKT	in

---

## Checking circuit pack configuration

The list configuration report provides a list of circuit packs that are connected to the configuration and recognized by the software.

To check circuit pack configuration:

1. Type `list configuration all` and press **Enter**.
2. Ensure that the software is communicating with each circuit pack, except the power supply circuit packs. Do not attempt to correct any problems until later, after you run the diagnostic tests.

3. Note any circuit packs for which the **VINTAGE** column shows **NO BOARD** or **CONFLICT**.  
The letter **u** indicates unassigned ports, and a number indicates that the port was translated.

---

## Testing the TN2312BP IPSI circuit pack

To test the TN2312BP Internet Protocol Server Interface (IPSI) circuit pack with Avaya Site Administration:

- Type **test ipserver-interface** `UUC` and press **Enter** to test all clock and packet interface components within the IPSI circuit pack

---

## Testing bearer duplication with the TN2602AP circuit pack

To verify that calls are being processed with the TN2602AP circuit packs:

1. Make an external trunk call to a telephone on the port network and leave the call active.
2. Type **status media-processor board** `UUCSS`, where `UUCSS` is the location of the active circuit pack.  
The Media Processor Status screen appears.
3. Look at the **LINKS** and **DSP CHANNEL STATUS** categories to determine whether the call is being processed.
4. Type **set media-processor** `UUCSS`, where `UUCSS` is the location of the standby TN2602AP circuit pack.  
The standby TN2602AP circuit pack becomes active.
5. Type **status media-processor board** `UUCSS`, where `UUCSS` is the location of the newly active circuit pack.

The Media Processor Status screen appears. Under **DSP CHANNEL STATUS**, the test call has moved to the column for the newly active TN2602AP circuit pack.

## Testing the TDM bus for each PN

To check each TDM bus for each PN in the configuration.

1. Type `test tdm port-network 1` and press **Enter**.
2. If the result is **FAIL** for any test, check the connectors of the TDM bus cables in PN 2.
3. Repeat these steps to check the TDM bus cables for each PN.

---

## Saving translations, if required

To save translations to the hard drive:

- Type `save translations` and press **Enter**.

---

## Testing telephones and other equipment

This section describes how to test the telephones and other equipment. Perform these tests after the equipment is wired to the media gateway and after you administer the customer data for that equipment. The tests are acceptance tests and provide some assurance that the system will perform properly after installation and administration.

If problems occur or more extensive tests are required, see the maintenance book for your configuration.

Perform the following tasks to complete the acceptance tests:

- [Making test calls](#) on page 61
- [Testing the 302C attendant console](#) on page 62
- [Testing selector console](#) on page 62
- [Testing external ringing](#) on page 63
- [Testing the queue warning indicator](#) on page 63
- [Testing integrated announcement](#) on page 63
- [Testing music-on-hold](#) on page 64
- [Testing emergency transfer](#) on page 64
- [Testing terminating trunk transmission](#) on page 65
- [Testing connectivity to the LAN](#) on page 66

---

## Making test calls

Make two calls from one telephone to another telephone. To make the first call, dial a telephone. To make the second call, dial a trunk access code and a listed directory number (LDN).

## Testing the 302C attendant console

To verify that all lamps are operational and call another telephone in the configuration:

1. Simultaneously press and hold **Ringer Volume up** and **POS BUSY**.

This action puts the console in the self-test mode.

**Note:**

When you release the buttons, the console returns to normal mode.

2. Verify that all lamps on the display light and remain lighted, and that each row of lamps on the console lights and goes dark in sequence from top to bottom.
3. Press **Start** and listen for a dial tone.

Verify that the green lamp associated with Idle Call Appearance lights up and that the Position Available lamp goes dark.

4. Dial the number associated with a working telephone.

Verify that you hear an audible ringing tone in the ear piece.

5. Press **Release**.

Verify that the audible ringing tone is silenced, the green lamp that is associated with idle call appearance button goes dark, and the Position Available lamp lights.

---

## Testing selector console

To verify that all selector console lamps are operational and make a call to a telephone in the configuration:

1. Simultaneously press and hold **Ringer Volume up** and **POS BUSY** on the attendant console.

This action puts the console in the self-test mode.

Verify that each row of lamps on the selector console lights and goes dark in sequence from top to bottom.

2. Press the hundreds group select button.

Verify that the hundreds group select lamp and any lamps that are associated with a busy telephone light.

3. Press **Direct Extension Selection (DXS)** for the extension that you want to test.

Verify that you hear an audible ringing tone in the ear piece on the attendant console.

4. On the attendant console, press **Release**.

The audible ringing tone is silenced.

---

## Testing external ringing

Make a test call to the attendant console to verify ringing device sounds when the Night lamp on console is lighted. If the console does not include a ringing device, connect a spare telephone to the information outlet that is reserved for ringing device. Then make the test call.

---

## Testing the queue warning indicator

Make a test call to an extension that is associated with a uniform call distribution (UCD) or a direct department calling (DDC) group. Verify that the queue warning indicator lamp lights up. If the queue warning indicator was not installed by the customer, connect a spare telephone to the information outlet that is reserved for queue warning indicator. Then make the test call.

---

## Testing integrated announcement

The TN2501AP Announcement circuit packs can store messages. The messages can be recorded from telephones that are on or off the premises and have flexible message lengths. The telephone that you select as the test telephone must have a class of service (COS) with console permission enabled.

## Recording an announcement

To record an announcement:

1. Select a test telephone on which console permission is enabled.
2. Dial the access code and then the integrated announcement extension number.
3. When you hear a dial tone, press **1**. When you hear a beep or a stutter tone, speak the announcement into the telephone.
4. When you finish, press the pound sign (**#**) if the telephone is a digital telephone or hang up if the telephone is an analog telephone to stop the recording.

Verify that you then hear a dial tone.

---

## Playing back an announcement

To play back an announcement:

1. If the telephone is a digital telephone, press **2** to hear the announcement. If the telephone is an analog telephone, dial the integrated announcement extension number to hear the announcement. When the announcement is over, verify that you hear a dial tone.
  2. When you finish, hang up the telephone.
- 

## Deleting an announcement

To delete an announcement:

1. Dial the access code and then the integrated announcement extension number.
2. When you hear a dial tone, press **3** to delete the announcement and stop the recording session.

Verify that you hear a confirmation tone when you delete the announcement.

---

## Testing music-on-hold

Verify that music is provided to a held party during any hold interval.

---

## Testing emergency transfer

Put the configuration in emergency transfer mode and make a call with an emergency transfer telephone. There can be up to four Emergency Transfer panels on a wall in the telephone closet, depending on the configuration.

---

## Testing terminating trunk transmission

The terminating trunk transmission test provides extension number access to three tone sequences. These tone sequences can be used for trunk transmission testing from the distant end of the trunks.

To test terminating trunk transmission:

1. Type **change system-parameters maintenance** and press **Enter**. Go to screen 2.
2. Under TERMINATING TRUNK TRANSMISSION TEST (Extension), type in 3 extension numbers in the 3 fields provided:

Test type 100: \_\_\_\_\_ Test type 102: \_\_\_\_\_ Test type 105: \_\_\_\_\_

Test type	Test features
Test type 100	<ul style="list-style-type: none"> <li>● 5.5 seconds of 1004 Hz tone at 0 dB</li> <li>● Quiet until disconnect. Disconnect is forced after 1 minute</li> </ul>
Test type 102	<ul style="list-style-type: none"> <li>● 9 seconds of 1004 Hz tone at 0 dB</li> <li>● 1 second of silence</li> <li>● The cycle is repeated until disconnect, which is forced after 24 hours</li> </ul>
Test type 105	<ul style="list-style-type: none"> <li>● 9 seconds of a 1004 Hz tone at -16 dB</li> <li>● 1 second of silence</li> <li>● 9 seconds of 404 Hz tone at -16 dB</li> <li>● 1 second of silence</li> <li>● 9 seconds of 2804 Hz tone at -16 dB</li> <li>● 30 seconds of silence</li> <li>● 0.5 seconds of test progress tone (2225 Hz)</li> <li>● About 5 seconds of silence</li> <li>● Forced disconnect</li> </ul>

---

## Testing connectivity to the LAN

To test the external IP connections for the C-LAN, IP Media Processor, and VAL circuit packs, you must ping both the circuit pack and a known computer that is connected to your network. If everything is configured correctly, the **Result** column on the **Ping Results** screen shows **PASS**. If the Result column reads **ABORT**, verify the IP-address information and check the connectivity, including the cabling.

To test connectivity to the LAN:

1. Type `ping ip-address IPaddress board UUCSS`, where *IPaddress* is the IP address of the circuit pack and *UUCSS* is the cabinet and slot of the circuit pack.
2. Press **Enter**.
3. Type `ping ip-address IPaddress board UUCSS`, where the variable *IPaddress* is the IP address of another computer beyond the gateway and *UUCSS* is the cabinet and slot of the circuit pack. Press **Enter**.

---

## LED indicators

To access detailed alarm and LED descriptions, see the maintenance book for your system. If a maintenance object starts to fail some periodic tests, the server generates an alarm. The server identifies three levels of alarms:

- Major alarms. Failures that cause critical degradation of service and require immediate attention.
- Minor alarms. Failures that cause some degradation of service, but do not cause a critical portion of the configuration to be inoperable. This condition requires action, but the consequences of a minor alarm are not immediate. Problems might be impaired service to a few trunks or stations or interference with one feature across the entire configuration.
- Warning alarms. Failures that cause no significant degradation of service or failures in equipment that is external to the configuration. Warning alarms are not reported to the attendant console or INADS.

Alarms are communicated to users and technicians by entries in the alarm and sys logs and the lighting of LEDs. The LEDs are located on the attendant console, on all circuit packs, and, optionally, on customer-designated telephones.

---

## Telephone console LEDs

Telephones and attendant consoles have some alarm LEDs that must be checked.

---

## Attendant console LEDs

The console has two red LEDs. These LEDs are labeled “ALM” and “ACK.” The ALM LED lights steadily when a major or minor alarm exists at the server. The ACK LED lights steadily if the alarm was successfully reported to INADS. If the server cannot report the alarm to INADS, the LED flashes. This flashing LED signals the attendant to call INADS and report the alarm.

---

## Terminal alarm notification

Terminal Alarm Notification is an optional feature that displays several types of alarms on telephones with administered feature buttons or the attendant console. A maximum of 10 digital telephones, hybrid telephones, or both can be used.

When an alarm occurs, the green status LED that is associated with the assigned button is in a steady state. Turn off the LED by pressing the button associated with the LED. If the LED is off and the alarm was not resolved by the time maintenance reschedules testing, the green status LED resumes its steady state.

## Testing the complete configuration

# Index

## A

AC load center . . . . .	<a href="#">33</a>
AC outlet	
testing . . . . .	<a href="#">34</a>
AC power	
checking . . . . .	<a href="#">33</a>
connecting . . . . .	<a href="#">36</a>
ground wiring . . . . .	<a href="#">31</a>
grounding . . . . .	<a href="#">17</a>
AC power receptacles . . . . .	<a href="#">13</a>
AC power supply . . . . .	<a href="#">33</a> , <a href="#">34</a>
AC voltage test . . . . .	<a href="#">33</a>
alarms . . . . .	<a href="#">66</a>
terminal alarm notification . . . . .	<a href="#">67</a>
announcements	
deleting . . . . .	<a href="#">64</a>
playback procedure . . . . .	<a href="#">64</a>
recording . . . . .	<a href="#">64</a>
testing . . . . .	<a href="#">63</a>
approved grounds . . . . .	<a href="#">17</a> , <a href="#">30</a> , <a href="#">31</a>
attendant console	
LEDs . . . . .	<a href="#">66</a> , <a href="#">67</a>
testing . . . . .	<a href="#">62</a>

## B

bearer duplication . . . . .	<a href="#">54</a>
testing . . . . .	<a href="#">59</a>

## C

cabling	
five media gateways . . . . .	<a href="#">44</a>
four media gateways . . . . .	<a href="#">43</a>
TDM/LAN . . . . .	<a href="#">41</a>
three media gateways . . . . .	<a href="#">43</a>
two media gateways . . . . .	<a href="#">42</a>
carrier address ID . . . . .	<a href="#">21</a>
chassis power source . . . . .	<a href="#">32</a>
check	
AC power . . . . .	<a href="#">33</a>
check customer's order . . . . .	<a href="#">14</a>
checking	
circuit pack configuration . . . . .	<a href="#">58</a>
system status . . . . .	<a href="#">58</a>
circuit packs	
allowable for G650 . . . . .	<a href="#">50</a>
configuration, testing . . . . .	<a href="#">58</a>

LEDs . . . . .	<a href="#">66</a>
programmable . . . . .	<a href="#">53</a> , <a href="#">54</a>
TN2501 . . . . .	<a href="#">55</a>
TN799DP . . . . .	<a href="#">53</a>
TN801B . . . . .	<a href="#">55</a>
C-LAN connection, testing . . . . .	<a href="#">66</a>
commercial AC power . . . . .	<a href="#">33</a>
connect	
AC power . . . . .	<a href="#">17</a> , <a href="#">36</a>
power cords . . . . .	<a href="#">33</a>
to customer network . . . . .	<a href="#">53</a>
console	
attendant, testing . . . . .	<a href="#">62</a>
selector, testing . . . . .	<a href="#">62</a>
coupled bonding conductor . . . . .	<a href="#">31</a>
current levels, worst case . . . . .	<a href="#">34</a>
customer network	
connecting to . . . . .	<a href="#">53</a>
customer's order	
checking . . . . .	<a href="#">14</a>
inspecting . . . . .	<a href="#">14</a>

## D

damage, reporting . . . . .	<a href="#">14</a>
DC power . . . . .	<a href="#">36</a>
DC power receptacles . . . . .	<a href="#">13</a>
DC power supply . . . . .	<a href="#">37</a>
direct department calling	
testing queue warning indicator . . . . .	<a href="#">63</a>
documentation	
downloading . . . . .	<a href="#">8</a>
related . . . . .	<a href="#">9</a>
updates . . . . .	<a href="#">8</a>
using . . . . .	<a href="#">8</a>
downloading documentation . . . . .	<a href="#">8</a>

## E

electrical connection . . . . .	<a href="#">17</a>
emergency transfer, testing . . . . .	<a href="#">64</a>
equipment, verifying . . . . .	<a href="#">15</a>
expansion links, service state . . . . .	<a href="#">58</a>
external ringing	
testing . . . . .	<a href="#">63</a>

## F

fan assembly . . . . .	<a href="#">21</a>
fuse, power supply . . . . .	<a href="#">28</a>

## Index

---

### G

G650 Media Gateway	
allowable circuit packs . . . . .	<a href="#">50</a>
cabling five media gateways . . . . .	<a href="#">44</a>
cabling four media gateways . . . . .	<a href="#">43</a>
cabling three media gateways . . . . .	<a href="#">43</a>
cabling two media gateways . . . . .	<a href="#">42</a>
carrier address ID . . . . .	<a href="#">21</a>
chassis power source . . . . .	<a href="#">32</a>
checking AC power . . . . .	<a href="#">33</a>
connect power cords . . . . .	<a href="#">33</a>
DC power . . . . .	<a href="#">36</a>
installing . . . . .	<a href="#">18</a>
mounting one gateway . . . . .	<a href="#">23</a>
mounting two to five gateways . . . . .	<a href="#">28</a>
power supply fuse . . . . .	<a href="#">28</a>
power switches . . . . .	<a href="#">40</a>
rack . . . . .	<a href="#">20</a>
required AC input current . . . . .	<a href="#">34</a>
required DC input current . . . . .	<a href="#">37</a>
specifications . . . . .	<a href="#">14</a>
TDM/LAN cabling . . . . .	<a href="#">41</a>
testing AC outlet . . . . .	<a href="#">34</a>
ventilation . . . . .	<a href="#">20</a>
verifying grounds . . . . .	<a href="#">35</a>
verifying voltages . . . . .	<a href="#">35</a>
ground wiring, AC . . . . .	<a href="#">31</a>
grounds	
approved . . . . .	<a href="#">17</a> , <a href="#">30</a> , <a href="#">31</a>
checking . . . . .	<a href="#">17</a>
connecting . . . . .	<a href="#">31</a>
connecting AC . . . . .	<a href="#">17</a>
single-point . . . . .	<a href="#">31</a>
verifying . . . . .	<a href="#">35</a>

---

### H

high-level overview of installation process . . . . .	<a href="#">11</a>
humidity . . . . .	<a href="#">20</a>

---

### I

inspect customer's order . . . . .	<a href="#">14</a>
inspecting G650 media gateway	
media gateway	
unpacking . . . . .	<a href="#">15</a>
installation process	
high-level overview . . . . .	<a href="#">11</a>
installing	
G650 Media Gateway . . . . .	<a href="#">18</a>
TN2312BP . . . . .	<a href="#">29</a>
integrated announcement	
testing . . . . .	<a href="#">63</a>

IP network connection, testing . . . . .	<a href="#">66</a>
IPSI . . . . .	<a href="#">13</a>

---

### L

LEDs	
alarms . . . . .	<a href="#">66</a>
attendant consoles . . . . .	<a href="#">67</a>
light emitting diodes. See LEDs.	

---

### M

media gateway	
grounds . . . . .	<a href="#">17</a>
inspecting . . . . .	<a href="#">15</a>
media gateway installation	
AC power and ground . . . . .	<a href="#">17</a>
mounting	
one G650 Media Gateway . . . . .	<a href="#">23</a>
two to five G650 Media Gateways . . . . .	<a href="#">28</a>
music-on-hold, testing . . . . .	<a href="#">64</a>

---

### N

National Electrical Code	
grounding rules . . . . .	<a href="#">17</a>
NEC. See National Electrical Code	
night ringing, testing . . . . .	<a href="#">63</a>

---

### O

order checking . . . . .	<a href="#">14</a>
--------------------------	--------------------

---

### P

packing lists . . . . .	<a href="#">14</a>
playback announcement, testing . . . . .	<a href="#">64</a>
port network	
TDM bus, testing . . . . .	<a href="#">60</a>
power	
receptacles . . . . .	<a href="#">13</a>
power cords	
connecting . . . . .	<a href="#">33</a>
routing . . . . .	<a href="#">33</a>
power holdover . . . . .	<a href="#">39</a>
power supply	
uninterruptible . . . . .	<a href="#">39</a>
power supply fuse . . . . .	<a href="#">28</a>
power switches	
media gateways . . . . .	<a href="#">40</a>
pre-installation setup . . . . .	<a href="#">10</a>
programmable circuit packs	
TN2302AP . . . . .	<a href="#">53</a>
TN2501 . . . . .	<a href="#">55</a>

TN2602AP . . . . .	<a href="#">54</a>
TN799DP . . . . .	<a href="#">53</a>

## Q

queue warning indicator testing . . . . .	<a href="#">63</a>
---	--------------------

## R

rack . . . . .	<a href="#">20</a>
rack requirements . . . . .	<a href="#">13</a>
recorded announcement, testing . . . . .	<a href="#">64</a>
reference IPSI . . . . .	<a href="#">13</a>
reporting damage . . . . .	<a href="#">14</a>
required input current . . . . .	<a href="#">34</a> , <a href="#">37</a>
requirements	
rack . . . . .	<a href="#">13</a>
ringing, testing . . . . .	<a href="#">63</a>
route power cords . . . . .	<a href="#">33</a>

## S

selector console, testing . . . . .	<a href="#">62</a>
service states, checking . . . . .	<a href="#">58</a>
shipping errors, correcting . . . . .	<a href="#">16</a>
shipping packing lists . . . . .	<a href="#">14</a>
single-point ground block . . . . .	<a href="#">31</a>
single-point grounds . . . . .	<a href="#">31</a>
SIPI . . . . .	<a href="#">13</a>
specifications . . . . .	<a href="#">14</a>
system status, checking . . . . .	<a href="#">58</a>

## T

TDM bus	
service state . . . . .	<a href="#">58</a>
testing . . . . .	<a href="#">60</a>
TDM/LAN cabling . . . . .	<a href="#">41</a>
telephone calls	
making test calls . . . . .	<a href="#">61</a>
terminal alarm notification	
alarms . . . . .	<a href="#">67</a>
terminating trunk transmission test types . . . . .	<a href="#">65</a>
terminating trunk transmission testing . . . . .	<a href="#">65</a>
temperature . . . . .	<a href="#">20</a>
test types, terminating trunk transmission . . . . .	<a href="#">65</a>
testing	
bearer duplication . . . . .	<a href="#">59</a>
complete configuration . . . . .	<a href="#">57</a>
emergency transfer . . . . .	<a href="#">64</a>
external ringing . . . . .	<a href="#">63</a>
integrated announcements . . . . .	<a href="#">63</a>
IP network connection . . . . .	<a href="#">66</a>

music on hold . . . . .	<a href="#">64</a>
night ringing . . . . .	<a href="#">63</a>
playback announcement . . . . .	<a href="#">64</a>
queue warning indicator . . . . .	<a href="#">63</a>
selector console . . . . .	<a href="#">62</a>
TDM bus . . . . .	<a href="#">60</a>
terminating trunk transmission . . . . .	<a href="#">65</a>
TN2312AP/BP . . . . .	<a href="#">59</a>
TN2602AP circuit pack . . . . .	<a href="#">59</a>
testing AC outlet . . . . .	<a href="#">34</a>
TN2302AP IP Media Processor . . . . .	<a href="#">53</a>
TN2312AP/BP	
testing . . . . .	<a href="#">59</a>
TN2312BP, installing . . . . .	<a href="#">29</a>
TN2501 Voice over the LAN circuit pack . . . . .	<a href="#">55</a>
TN2602AP circuit pack	
testing . . . . .	<a href="#">59</a>
TN2602AP IP Media Resource circuit pack . . . . .	<a href="#">54</a>
TN799DP C-LAN circuit pack . . . . .	<a href="#">53</a> , <a href="#">66</a>
TN801B MAP-D circuit pack . . . . .	<a href="#">55</a>
tone clocks	
service state . . . . .	<a href="#">58</a>

## U

uniform call distribution	
testing queue warning indicator . . . . .	<a href="#">63</a>
uninterruptible power supply . . . . .	<a href="#">39</a>
unpacking G650 media gateway . . . . .	<a href="#">15</a>
updates from the Web . . . . .	<a href="#">8</a>
UPS . . . . .	<a href="#">39</a>

## V

VAL. See TN2501 Voice over the LAN.	
ventilation . . . . .	<a href="#">20</a>
verify	
ground . . . . .	<a href="#">35</a>
voltages . . . . .	<a href="#">35</a>
voltages	
verifying . . . . .	<a href="#">35</a>

## W

worst case current levels . . . . .	<a href="#">34</a>
-------------------------------------	--------------------

